



Commercial VRF Systems

Panasonic VRF Systems are specifically designed for energy saving, easy installation and high efficiency performance. A wide range of outdoor and indoor unit models offer unique features which are designed for the most demanding offices and large buildings.

ECO*i* EX

ECO*i*

ECO G





VRF highlighted features	→ 234	ECOi and ECO G indoor units range	→ 310
Panasonic: delivering TOP energy efficiencies for many years	→ 236	U2 type 4 way 90x90 cassette · R32 / R410A	→ 313
Bringing nature's balance indoors	→ 238	Y3 type 4 way 60x60 cassette · R32 / R410A	→ 314
BION air pollutant filter	→ 240	L1 type 2 way cassette · R410A	→ 315
Panasonic VRF: TOP in comfort	→ 242	D1 type 1 way cassette · R410A	→ 316
Solutions for Restaurants	→ 244	F3 type variable static pressure adaptive duct · R32 / R410A	→ 317
Your entire hotel with superior comfort, control and savings too	→ 246	M1 type slim variable static pressure hide-away concealed duct · R32 / R410A	→ 318
Innovative solutions for retail	→ 248	E2 type high static pressure hide-away · R410A	→ 319
Best efficiency ECOi Series from Panasonic	→ 252	T2 type ceiling · R410A	→ 320
Mini ECOi LZ2 Series R32	→ 254	K2 type wall-mounted · R32 / R410A	→ 321
Mini ECOi LE Series	→ 260	G1 type floor console · R410A	→ 322
ECOi EX. The Game Changer	→ 266	P1 type floor-standing · R410A	→ 323
Slim 3-Pipe control box kit / Multiple connection type	→ 283	R1 type concealed floor-standing · R410A	→ 324
ECO G, the gas driven VRF	→ 288	Hydrokit for ECOi, water at 45 °C · R410A	→ 325
Panasonic GHP/EHP Hybrid System	→ 298		
Water heat exchanger for hydronic applications	→ 302	Ventilation	
Leak detection and automatic refrigerant Pump Down for R410A refrigerant	→ 306	AHU connection kit MAH4M for ECOi 2-Pipe	→ 326
		AHU connection kit MAH3M for ECOi and ECO G	→ 327
VRF outdoor units range	→ 250	Energy recovery ventilation	→ 328
Mini ECOi LZ2 Series 4 to 6 HP · R32	→ 258	Energy recovery ventilation with DX coil - HRPT Series · R32 / R410A	→ 330
Mini ECOi LZ2 Series 8 and 10 HP · R32	→ 259	Heat recovery with DX coil - ZDX Series · R410A	→ 331
Mini ECOi LE2 Series 4 to 6 HP · R410A	→ 264	Air curtain with DX coil, connected to VRF systems	→ 332
Mini ECOi LE1 Series 8 and 10 HP · R410A	→ 265	Ceiling mounted air-e nanoe X Generator	→ 333
2-Pipe ECOi EX ME2 Series	→ 277		
3-Pipe ECOi EX MF3 Series	→ 286	Fan coils units	→ 334
2-Pipe ECO G GE3 Series	→ 294	Smart fan coils	→ 335
3-Pipe ECO G GF3 Series	→ 297	Fan coil comfort AC fan	→ 336
2-Pipe Hybrid GHP/EHP	→ 301	Fan coil wall AC fan	→ 338
ECOi 2-Pipe with water heat exchanger	→ 304		
ECO G with water heat exchanger	→ 305	Accessories and control	→ 340
Panasonic DX PRO Designer	→ 308	Dimensions and tube sizes of branches and headers	→ 348
R22 Renewal	→ 309		
		Eurovent certified technical data	→ 352

VRF highlighted features

Panasonic provides an extensive range of solutions for medium and large sized buildings, combining the best options to satisfy all needs and site restrictions.



ECOi. Electrical VRF				ECO G. Gas Powered VRF	
2-Pipe Mini ECOi LZ2 · R32	2-Pipe Mini ECOi LE2 / LE1 · R410A	2-Pipe ECOi EX	3-Pipe ECOi EX	2-Pipe ECO G GE3	3-Pipe ECO G GF3
Capacity range					
4 - 10 HP	4 - 10 HP	8 - 80 HP	8 - 48 HP	16 - 60 HP	16 - 25 HP
Extreme temperatures operation					
-20 °C (heating) / 52 °C (cooling)	-20 °C (heating) / 46 °C (cooling)	-25 °C (heating) / 52 °C (cooling)	-20 °C (heating) / 52 °C (cooling)	-21 °C (heating) / 43 °C (cooling)	-21 °C (heating) / 43 °C (cooling)
Maximum number of connectable indoor units					
16 ¹⁾	15	64	52	64	24
Indoor to outdoor connection ratio					
50 ~ 150%	50 ~ 130%	50 ~ 200%	50 ~ 150%	50 ~ 200% ²⁾	50 ~ 200%
Indoor units					
All (check restrictions)					
Controls					
All					
Other ranges integration					
PACi range full control integration + Domestic range integration by accessory					

1) For 6 HP model. 2) 50 ~ 200% only when one outdoor unit is installed. In other cases 50 ~ 130%.

Uniquely, you can choose from both electric and gas-powered VRF systems from Panasonic, delivering the best choice and flexibility for our customers.

Providing a large choice of indoor units, you can also connect water heat exchangers, air handling units and ventilation units with or without a heat exchanger. And all managed from a simple and powerful stand-alone remote control, centralised controls or cloud connection with 3G embedded.

This cutting edge control technology is called VRF Smart Connectivity, combining the expertise of VRF communication and a leading BMS company to maximise comfort and efficiency while also reducing installation costs.

Panasonic ECOi is Eurovent certified. Panasonic's VRF systems - ECOi range is now certified by Eurovent*. The Eurovent certification verifies the performance ratings of heating and cooling systems following European standards. Those data provides products efficiency with full transparency for the benefit of customers and professionals.



* Reference website: <https://www.eurovent-certification.com/en>.

Energy saving



Refrigerant R32.

Our heat pumps containing R32 refrigerant show a drastic reduction in the value of Global Warming Potential (GWP).



Inverter Plus system.

Inverter Plus system classification highlights Panasonic's highest performing systems.



Panasonic R2 rotary compressor.

Designed to withstand extreme conditions, it delivers high performance and efficiency.



All Inverter compressors.

Multiple large-capacity all Inverter compressors (more than 14 HP). Two independently controlled Inverter compressors achieve high efficiency. Redesigned components in the body provide performance improvement especially in the rated cooling condition and EER performance.



High COP.

High efficiency models performs higher COP than standard units and standard combinations.



Gas powered.

ECO G technology offers the best in energy efficiency. ECO G gas VRF is specially designed for buildings where the electricity is restricted or CO₂ emissions must be reduced.



Econavi.

Intelligent human activity sensor and sunlight sensor technologies that can detect and reduces the waste of energy by optimising air conditioner operation according to room conditions. With just one touch of a button, you can save energy.



ErP 2018.

Compliant following COMMISSION REGULATION (EU) No2016/2281.

High performance and indoor air quality



Bluefin.

Panasonic has extended the life of its condensers with an original anti-rust coating.



Down to -10 °C in cooling mode.

The air conditioner works in cooling mode when the outdoor temperature of -10 °C.



Down to -25 °C in heating mode.

The air conditioner works in heat pump mode when the outdoor temperature is as low as -25 °C.



Cooling with outdoor temperature up to 52 °C.

The ECOi EX system works in cooling mode with performance data at outdoor temperature up to 52 °C.



Automatic restart.

Automatic restart function for power failure. Even when power failure occurs, preset programmed operation can be reactivated once power is resumed.



R22 renewal.

The Panasonic renewal system allows good quality existing R22 pipe work to be re-used whilst installing high efficiency R410A systems.



nanoe™ X.

Technology with the benefits of hydroxyl radicals has the capacity to inhibit pollutants, viruses, and bacteria to clean and deodorise.



Self-diagnosing function.

By using electronic control valves past warnings are stored. This makes it easier to diagnose malfunctions, reducing service labour and therefore costs.



Automatic fan operation.

Convenient microprocessor control automatically adjusts fan speed to High, Medium or Low, corresponding to room sensor and maintains comfortable air flow throughout the room.



Mild Dry.

By intermittent control of compressor and indoor unit's fan, "Mild Dry" gives you comfort. It realizes efficient dehumidification according to room temperature.



Comfortable auto-flap control.

When the unit is first turned on, flap position is automatically adjusted in accordance with the cooling or heating operation.



Air Sweep.

The air sweep function moves the flap up and down in the air outlet, directing air in a "sweeping" motion around the room and providing comfort in every corner.



Built-in drain pump.

Maximum head 50 cm (or 75 cm for U type) from the bottom of the unit.



Filter included.

Hide-away with filter included.



5 Years compressor warranty.

We guarantee the outdoor unit compressors in the entire range for five years.

High connectivity



Domestic integration to S-Link - CZ-CAPRA1.

Can connect RAC range to S-Link. Full control is now possible.



Internet control.

A next generation system providing user-friendly control of air conditioning or heat pump units from everywhere, using a simple Android™ or iOS smartphone or tablet via Wi-Fi.



BMS connectivity.

The communication port can be integrated into the indoor unit and provides easy connection to, and control of, your Panasonic air conditioner to your home or Building Management System.



Panasonic AC Smart Cloud.

The AC Smart Cloud from Panasonic allows you to have complete control of all your installations. In a simple click, receive status updates from all your units in real-time, preventing breakdowns and optimising costs.

Panasonic: delivering TOP energy efficiencies for many years



Particularly suitable for retail, hotels and office applications.

Outstanding efficiency at part load conditions:

Panasonic ECOi EX model covers down 30% part load with extremely high efficiency.

EER comparison of Panasonic 2-Pipe ECOi EX ME2 at different partial loads

Load %	100%	80%	60%	50%	40%	30%
18 HP High Efficiency model	4,54	5,30	6,37	7,12	8,23	6,93
18 HP Space saving model	3,38	3,97	4,75	5,25	5,13	4,97

Conditions: Outdoor temperature 35 °C DB, Room temperature 19 °C WB.

COP comparison of Panasonic 2-Pipe ECOi EX ME2 at different partial loads

Load %	100%	80%	60%	50%	40%	30%
18 HP High Efficiency model	3,89	5,42	6,90	6,94	6,59	6,11
18 HP Space saving model	3,43	4,90	6,36	6,59	6,33	5,92

Conditions: Outdoor temperature 0 °C WB, Room temperature 20 °C DB.

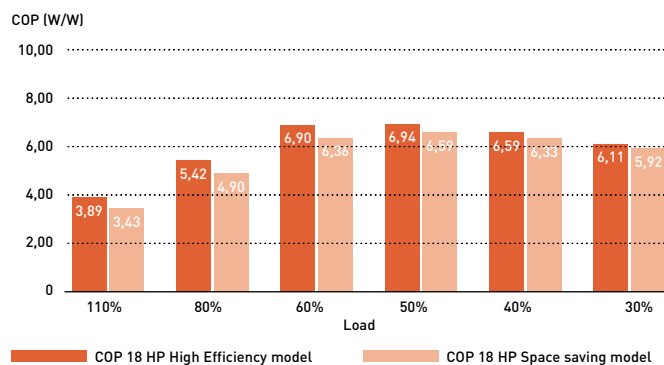
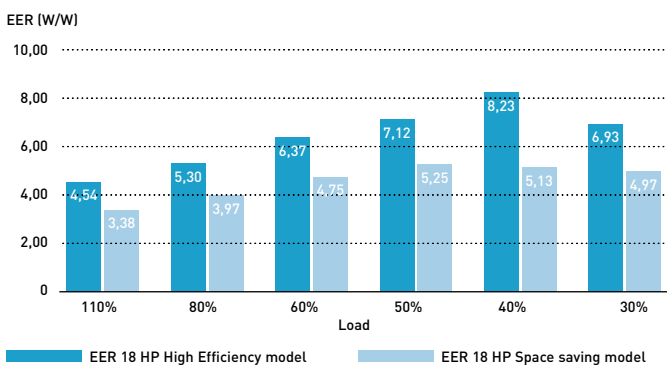

* Data from Panasonic official technical data book.

Excellent SEER and SCOP values for VRF 2 and 3-Pipe

Panasonic have a extremely high SEER and SCOP values following LOT21 (seasonal space cooling / heating energy efficiency by COMMISSION REGULATION (EU) 2016/2281).

HP	Mini ECOi (LZ)					Mini ECOi (LE)					2-Pipe				3-Pipe							
	4	5	6	8	10	4	5	6	8	10	8	10	12	14	16	18	20	8	10	12	14	16
SEER	8,50	8,12	7,71	7,56	7,08	7,85	7,48	7,25	6,27	6,37	7,43	6,96	6,74	7,23	6,43	7,56	7,03	7,02	7,05	6,39	6,69	6,02
$\eta_{s,c}$	337,0	321,8	305,4	299,4	280,2	311,0	296,2	286,8	247,9	251,8	294,3	275,4	266,6	286,0	254,3	299,2	278,2	277,7	278,9	252,7	264,4	237,7
SCOP	5,05	4,61	4,59	4,59	4,60	4,87	4,40	4,24	4,24	4,31	4,79	4,27	4,72	4,28	4,05	4,29	4,09	4,85	4,25	4,27	4,13	3,81
$\eta_{s,h}$	199,0	181,4	180,6	180,6	181,0	191,8	172,9	166,7	166,4	169,5	188,4	167,6	185,8	168,2	159,0	168,7	160,4	190,9	166,8	167,8	162,1	149,3

Efficient defrost operation

Panasonic uses the second unit to defrost the first unit. This makes the system more efficient during defrost and does not affect comfort.

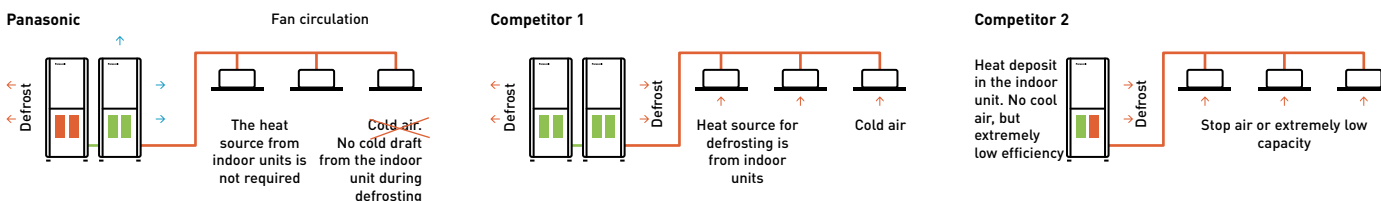

Panasonic ECOi operates down to -25 °C

This unique feature demonstrate the supremacy of Panasonic ECOi EX Series.

ECOi EX Series are capable of working in the challenging ambient condition. Heating operation is possible when outdoor temperature is as low as -25 °C.

Lowest operating outdoor temperature in the market -25 °C

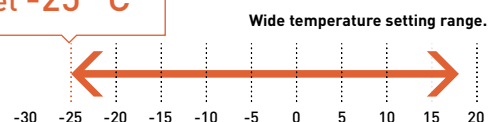

Bringing nature's balance indoors



nanoe™ X, technology with the benefits of hydroxyl radicals.

Abundant in nature, hydroxyl radicals (also known as OH radicals) have the capacity to inhibit pollutants, viruses, and bacteria to clean and deodorise. nanoe™ X technology can bring these incredible benefits indoors so that hard surfaces, soft furnishings, and the indoor environment can be a cleaner and more pleasant place to be, whether at home, work, or visiting hotels, shops and restaurants etc.



What is unique about nanoe™ X?

Effective on fabrics and surfaces.

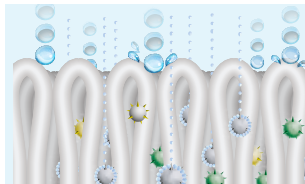

1 | At one billionth of a metre, nanoe™ X is much smaller than steam and can deeply penetrate cloth fabrics to deodorise.

Longer lifespan.



2 | Contained in tiny water particles, nanoe™ X has a long lifespan, which is about 600 seconds, to spread easily around the room.

Huge quantity.



3 | nanoe X Generator Mark 3 produces 48 trillion hydroxyl radicals per second. Greater amounts of hydroxyl radicals contained in nanoe™ X lead to higher performance on inhibition of pollutants.

Maintenance-free.

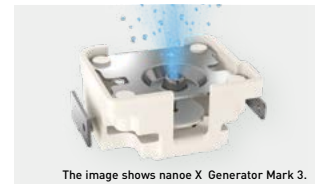

The image shows nanoe X Generator Mark 3.

4 | No service and maintenance required. nanoe™ X is a filter free solution that does not require maintenance, as its atomisation electrode is enveloped with water during its generation process and it is made with Titanium.

7 effects of nanoe™ X – Panasonic unique technology

Deodorises

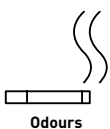

Odours

Capacity to inhibit 5 types of pollutants

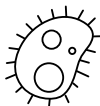

Bacteria and viruses

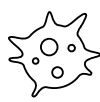

Mould

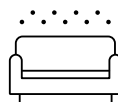

Allergens



Pollen



Hazardous substances



Skin and hair

* Refer to <https://aircon.panasonic.eu> for more details and validation data.

First nanoe™ device was developed by Panasonic in 2003

Generator: nanoe™

2003

480 billion hydroxyl radicals/sec

Ion particle structure

Hydroxyl radicals

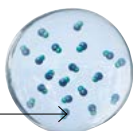

Generator: nanoe™ X

Mark 1 - 2016

4,8 trillion hydroxyl radicals/sec

10x times

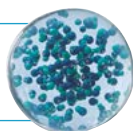

Mark 2 - 2019

9,6 trillion hydroxyl radicals/sec

20x times

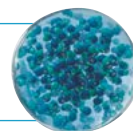

Mark 3 - 2022

48 trillion hydroxyl radicals/sec

100x times

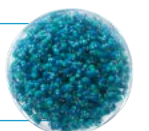

nanoe™ X has evolved again - the nanoe X Generator Mark 3.



The latest of the continuously evolving nanoe™ X technology, it has the largest amount of hydroxyl radical in the history of nanoe™ which generates 48 trillion hydroxyl radical per second, 100 times the hydroxyl radical contained in traditional nanoe™. The increased number of hydroxyl radical, which are the key to nanoe™ cleaning power, means you can expect an even higher level of performance.



nanoe™ X is an internationally-validated technology. Official test reports are available.

Licensed in VDI 6022

Certification of a HVAC system under VDI 6022 guarantees that the system fulfills the market's strictest hygiene requirements.

 <p>VDI 6022 – Part 5 ¹⁾ Certification.</p> <p>Avoidance of allergenic exposure.</p> <p>Inhibits a wide range of harmful bacteria, viruses, mould, pollen and allergens.</p>	 <p>VDI 6022 – Part 1 ¹⁾ & 1.1 ²⁾ Certification.</p> <p>Ventilation and indoor-air quality.</p> <p>Panasonic nanoe™ X technology improving indoor air quality.</p>
--	---

1) Certification mark only valid for nanoe X Generator Mark 3. 2) Certification mark only valid for nanoe X Generator Mark 2 and Mark 3.

Higher concentration, even in large spaces

Greater effectiveness even in large spaces of more than 100 m².

Simulation with nanoe X Generator Mark 3 in a room size of 112 m²

nanoe™ concentration level:

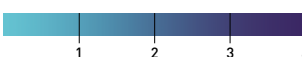

nanoe™ X diffuse into the space in a short time to quickly reach the effective concentration level.

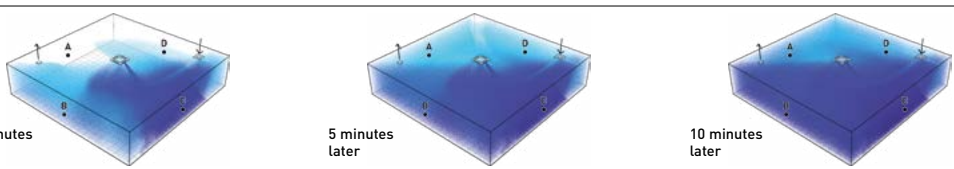

Conditions of the simulation: Inspection / model: 4 way cassette / room size: 112 m² / room height: 2,4 m / position of IDU: centre of space / ventilation: 3 times/hour.

Effectiveness in large space with Generator Mark 3

Inhibits virus.

An air conditioner equipped with nanoe X Generator Mark 3 inhibits activity of adhered virus (Bacteriophage) by 98,81% in 4 hours ¹⁾.

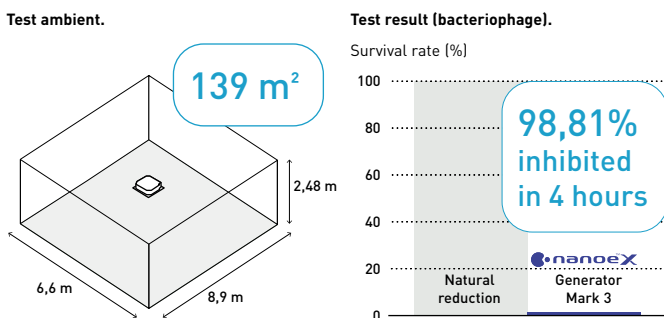

Inhibits pollen.

The result of nanoe X Generator Mark 3. Inhibits pollen in 1/4 the time of nanoe X Generator Mark 2 ²⁾.

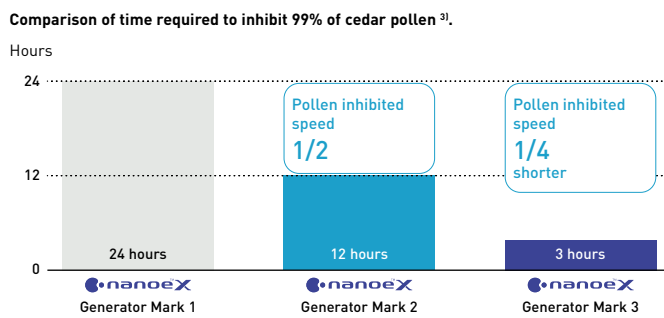

1) Testing organisation: SGS Inc / Test subject: Adhered Bacteriophage / Test volume: Approx. 139 m² large space (6,6 x 8,9 x 2,48 m). Test result: Inhibited 98,81% in 4 hours. Test report no.: SHES210901902583.
 2) Effect after 3 hours in a test space of approx. 24 m². The figures are not the results of testing in an actual operating space. 3) nano X Generator Mark 1: [Testing organisation] Panasonic Product Analysis Center [Test method] ELISA method of measuring allergens adhering to fabric in a test room (approx. 24 m²) [Method of inhibition] Release of nanoe™ [Target] Adhered allergen (cedar pollen) [Test Result] Inhibition of 99% or more in 24 hours (4AA33-151001-F01). nano X Generator Mark 2: [Testing organisation] Panasonic Product Analysis Center, [Test method] ELISA method of measuring allergens adhering to fabric in a test room (approx. 24 m²) [Method of inhibition] Release of nanoe™ [Target] Adhered allergen (cedar pollen) [Test Result] Inhibition of 99% or more in 12 hours confirmed (L19YA009). nano X Generator Mark 3: [Testing organisation] Panasonic Product Analysis Center [Test method] ELISA method of measuring allergens adhering to fabric in a test room (approx. 24 m²) [Method of inhibition] Release of nanoe™ [Target] Adhered allergen (cedar pollen) [Test Result] Inhibition of 99% or more in 3 hours (H21YA017-1).

Panasonic Heating & Cooling Solutions is incorporating nanoe™ technology in a wide range of equipment

 <p>U2 type 4 way 90x90 cassette. Built-in nanoe X Generator Mark 3.</p>	 <p>F3 type adaptive duct. Built-in nanoe X Generator Mark 3.</p>
 <p>Y3 type 4 way 60x60 cassette. Built-in nanoe X Generator Mark 3.</p>	 <p>G1 type floor console. Built-in nanoe X Generator Mark 1.</p>
	 <p>Ceiling mounted air-e nanoe X Generator. Built-in nanoe X Generator Mark 1.</p>

New BION air pollutant filter (optional)

Collaborating with BION, experts in filtration equipment, a new molecular filtration is available to improve indoor air quality.





The efficiency of nitrogen dioxide (NO₂) removal can reach 99,5%*

* Measured by ASTM6646 international standards. Efficiency reaches 99,5% within 4,8 seconds of contact time with the media bed (FAM filter). ** The performance varies depending on the room size, environment and usage and it may take several hours to reach the full effect. BION air pollutant filter is not medical device, local regulations on building design must be followed. Test results conducted under controlled laboratory conditions. Performance of BION air pollutant filter might differ in real life environment.

BION air pollutant filter traps and reduces certain types of harmful pollutant gases, listed below

- Nitrogen oxides (NO_x)
- Ozone (O₃)
- Sulfur dioxide (SO₂)
- Formaldehyde (HCHO)
- Volatile organic compounds (VOCs)

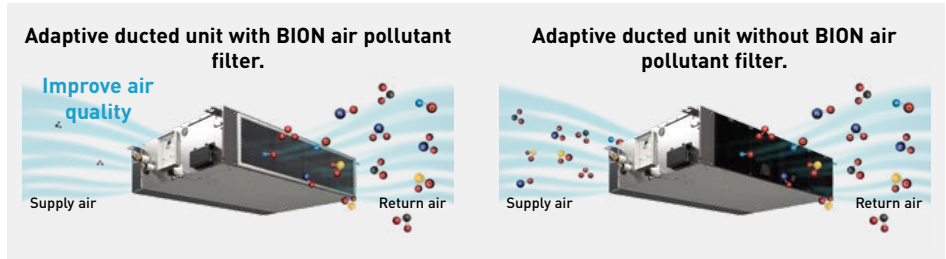

The BION air pollutant filter is an ideal solution for improving indoor air quality in urban areas.

Air pollution in urban areas in Europe

It is reported that in 2021, a significant portion of the Europe's urban population has been exposed to high levels of key air pollutants*.

- 75% of the urban population was exposed to NO₂ concentrations above 10 µg/m³
- 94% were exposed to concentrations of O₃ above 60 µg/m³

* The "Europe's Air Quality Status 2023" report (EEA, 2023) assesses levels of air pollutants measured in ambient air across Europe (> 2000 locations) for the years 2021 and 2022. It compares them against both EU standards as set out in the Ambient Air Quality Directives and the 2021 WHO Air Quality Guidelines.

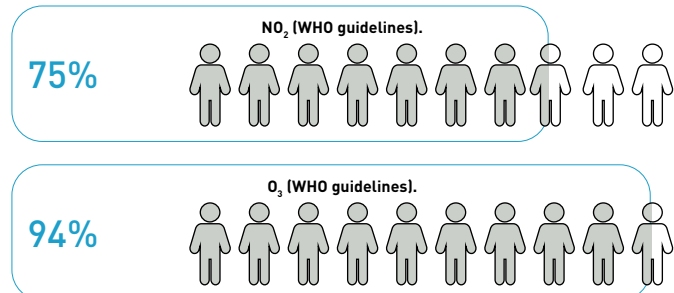

Share of the Europe's urban population exposed to air pollutant concentrations above EU standards and WHO guidelines in 2021, as referenced in the EEA 2023.

Why outdoor air pollution matters to IAQ?

Poor indoor air quality is associated with outdoor air pollutants such as car exhaust and factory fumes, and the two are closely linked. A significant portion of human exposure to air pollution occurs when they are indoors.



Different objectives, different IAQ solutions

In today's world, we are concerned about wellbeing and the air we breathe. And technology exists to ensure improved indoor air quality. With the introduction of the new BION air pollutant filter, Panasonic offers IAQ solutions optimized for various target objectives.

IAQ Solution	nanoe™ X	BION air pollutant filter
Objectives	Inhibit particles such as pollutants, certain types of viruses, and bacteria to clean and deodorise.	Inhibit gases such as nitrogen oxides (NO _x), ozone (O ₃), sulfur dioxide (SO ₂), formaldehyde (HCHO) and volatile organic compounds (VOCs)
Technology	Hydroxyl radicals contained in water	Molecular filtration
Filtering mechanism	Physical capture of particles	Adsorption and absorption
Availability	Built into all air-to-air indoor units as a standard	Optional accessory for the adaptive ducted unit (PF3/MF3)

BION air pollutant filter*	PAW-APF800F	PAW-APF1000F	PAW-APF1400F
Compatible adaptive ducted unit	MF3 15, 22, 28, 36, 45 and 56	MF3 60 and 73	MF3 90, 106, 112, 140 and 160

* The filter cartridge and filter casing are included in the package.

Panasonic VRF: TOP in comfort

Since 2006, all Panasonic VRF systems have included special VET technology, with variable refrigerant temperature control, as standard.



Variable Evaporation and Condensation Temperature.

Our 'smart logic' system checks the temperature every 30 seconds, automatically adjusting the refrigerant temperature according to actual demand and outdoor conditions. This ensures better energy performance at all times.

Temperature varies from 16 °C to 3 °C.

Similarly, the condensation temperature is also variable and is adjusted to the room thermal load, within a range of 33 - 55 °C.

Refrigerant evaporation temperature (°C).

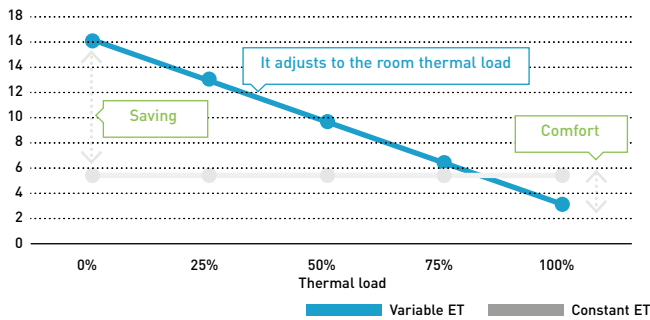

Refrigerant condensation temperature (°C).

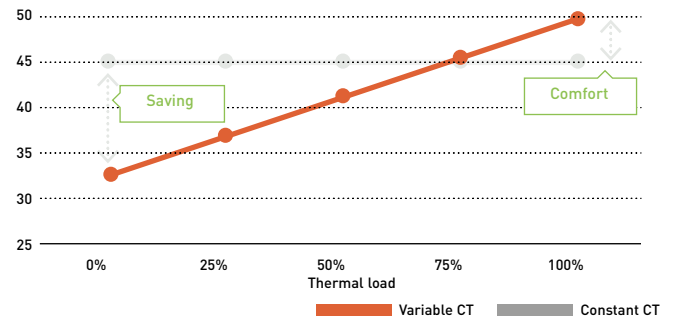

Example of cooling mode (similarly applicable to heating mode).

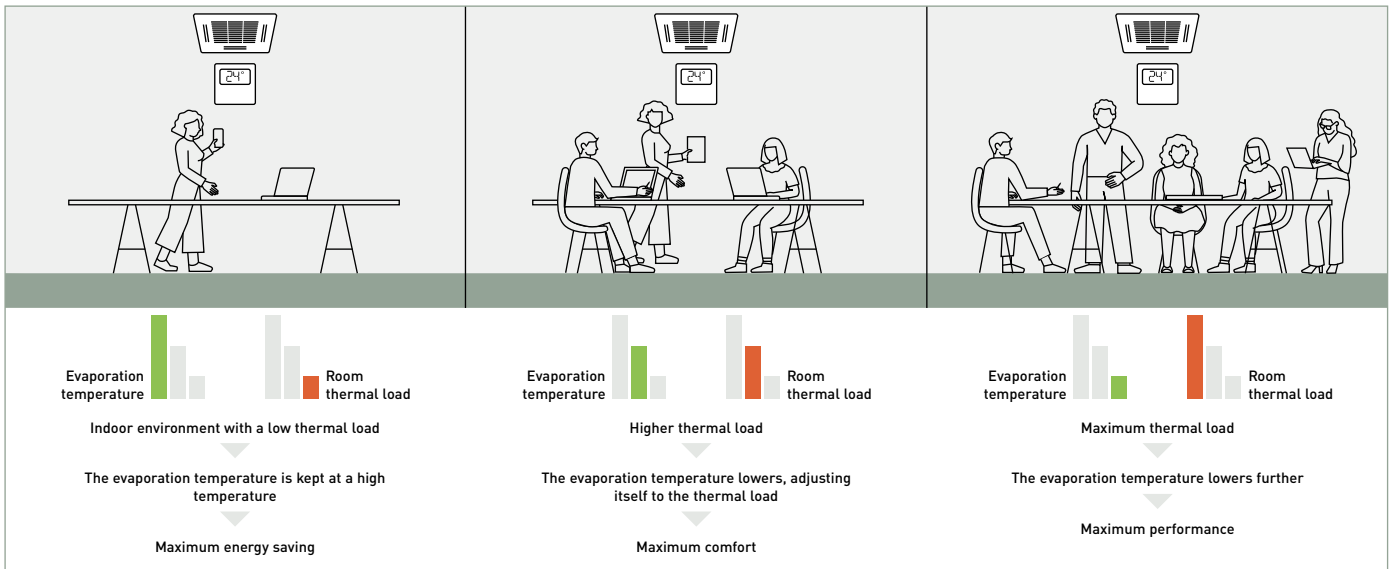

Technical focus on variable temperatures

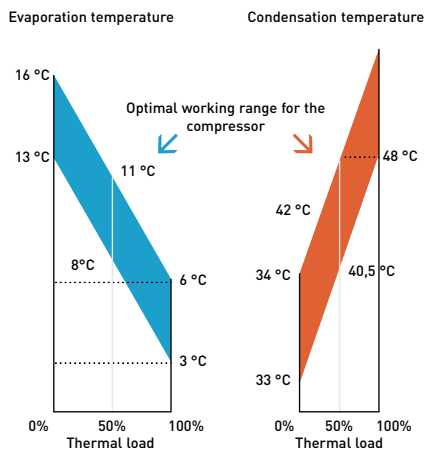

Control of the discharge temperature

This special function is available in all of Panasonic VRF systems' indoor units to guarantee maximum comfort for the end user. For example, in cooling mode, if the temperature of the discharged air was below 10 °C, the user may feel discomfort, just as he would do in heating mode if the temperature was far too high. With the Panasonic control of the discharge air temperature, this can be adjusted within a cooling range of 7 - 22 °C.

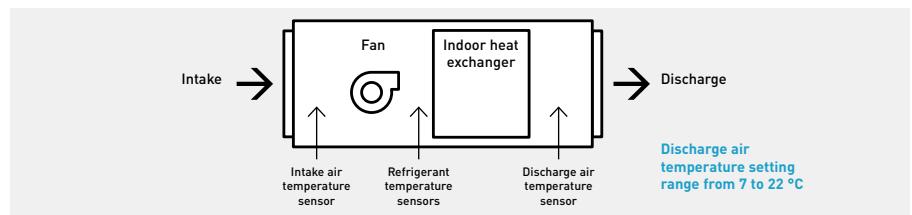

Benefits:

- The air will never be too cold or too warm
- Available in cooling and in heating
- Higher comfort
- Energy saving
- It prevents the formation of condensation within ducts and vents, improving levels of hygiene

Solutions for Restaurants

Full heating, cooling and DHW solutions for Restaurants.



1a Gas VRF. ECO G.

ECO G gas VRF is designed for buildings where the electricity is restricted or CO₂ emissions must be reduced. Sanitary hot water is produced for free, all year round.



1b Electric VRF. ECOi EX and Mini ECOi.

ECOi electrical VRF is specifically designed for the most demanding restaurants. High efficiency system. Extended operating range to provide heating at outdoor temperature as low as -25 °C (2-Pipe ECOi EX). Suitable for refurbishment projects.

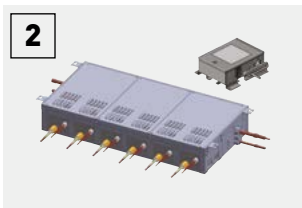

2 3-Pipe control box kit.

Heat Recovery box to connect multiple indoor units with just one box, 4, 6 and up to 8 indoor units or groups
This is good advantage in the restaurants, where space for connecting several boxes is limited.



3 Aquarea T-CAP.

Ideal for heating, cooling and for production of big quantities of hot water at 65 °C, Aquarea have a extremely quick return on investment and a low CO₂ footprint.



4 Water heat exchanger for ECOi and ECO G. Water up to 55 °C.

Producing hot water, compatible with both ECOi and ECO G, heat pump outdoor units.



5 AHU connection kit for efficient ventilation.

The AHU connection kit is specially designed to improve the efficiency of the pre-heating or pre-cooling ventilation process.

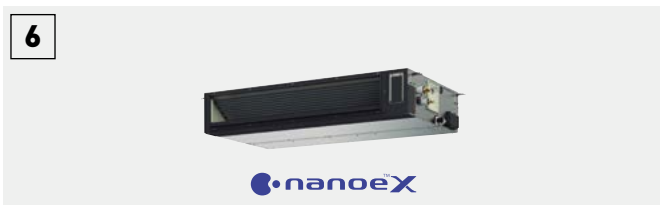

6 Adaptive ducted with nanoe™ X.

Super silent units deliver the ideal air supply. Units available from 1,5 kW providing precise temperature control even in small rooms. 2 installation possibilities (horizontal / vertical) with high ESP 150 Pa allows for flexible installation. nanoe™ X is built-in as standard.



7 Mini Cassette.

The Y3 type 4 way 60x60 cassette unit has modern and stylish panel design which matches with any type of the building design.



8 Control your way.

Wide variety of controls, from simple user control to full system control via remote access functionality. Touch panel and consumption control.



9 Air curtain with DX coil.

The Panasonic range of air curtains is designed for smooth operation and efficient performance.



10 Protocol friendly.

Great flexibility for integration into your KNX / Modbus / LonWorks / BACnet projects allows fully bi-directional monitoring and control of all the functioning parameters. Range of solutions to control locally or remotely the full system in bi-directional mode.



11 Panasonic AC Smart Cloud / Service Cloud.

Taking your business under control. The Service function makes maintenance work simpler.



12 Condensing unit with natural refrigerant.

Panasonic CO₂ unit is the natural choice for showcases and cold rooms in restaurants. Always fresh foods from a future-proof refrigeration technology, without any contamination risk.

Highly efficient at part load conditions.

Panasonic has solutions for optimising the installation of cooling, heating and DHW production in restaurants. While the kitchen needs cooling, heating is needed for DHW and also for heating the public area, with the advantage of 100% fresh air that removes odours. Combining all these needs smartly with Panasonic technology results in a simple and flexible system adaptable to any restaurant requests, with lower utility bills. Additionally, Panasonic is offering the unique solution for areas where electric power is limited, using ECO G. VRF units powered mainly by Natural Gas or Propane, bringing comfort and DHW anywhere.

For chiller options, please check chiller section.

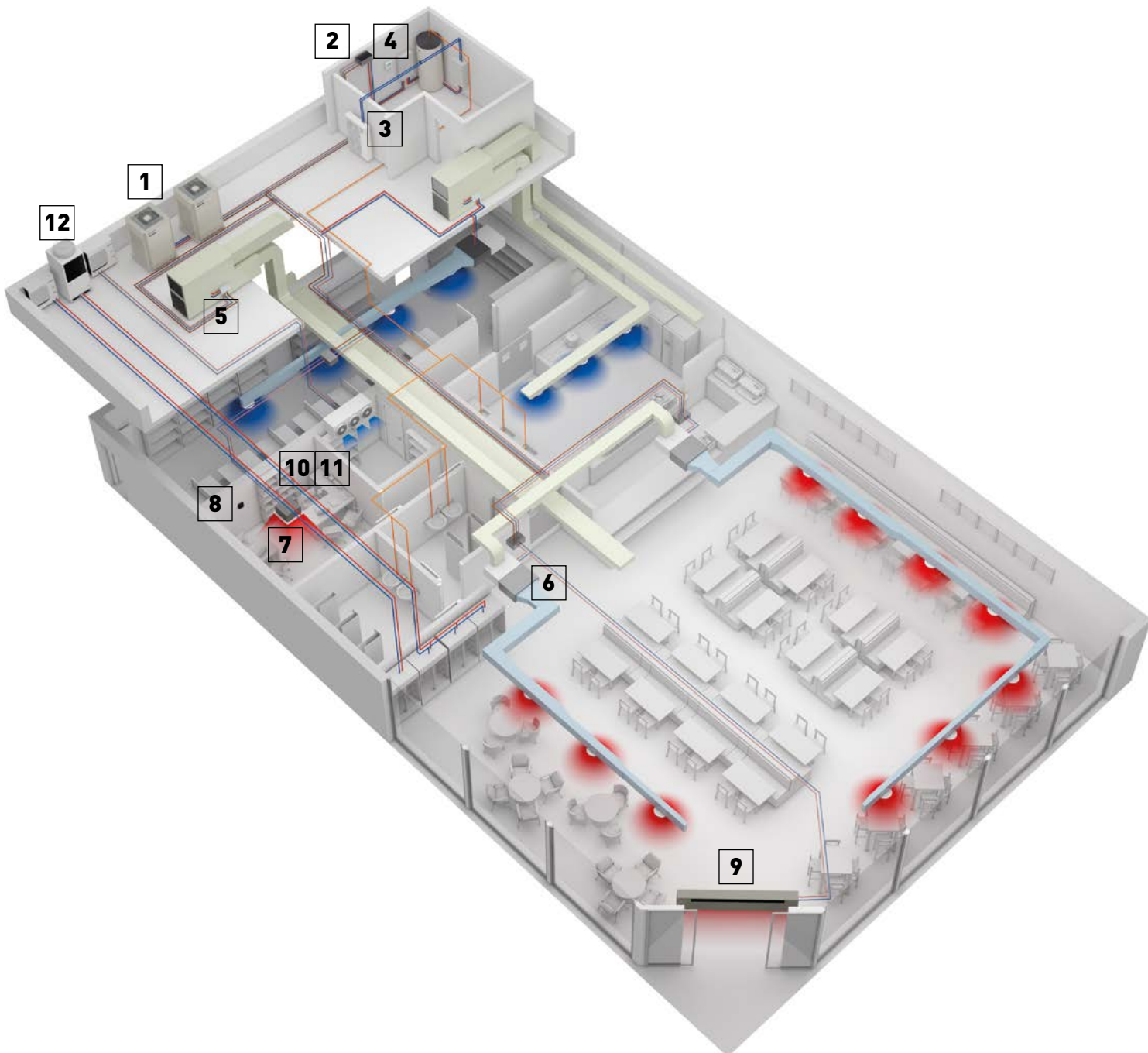

Your entire hotel with superior comfort, control and savings too



1a Hybrid system.
Gas + Electricity Hybrid system. Taking advantage of Gas and Electricity to achieve the most efficient performance and maximum energy saving, whilst reducing reliance on the electricity grid.



1b Gas VRF. ECO G.
ECO G gas VRF is designed for buildings where the electricity is restricted or CO₂ emissions must be reduced. Sanitary hot water is produced for free, all year round.



2 Hydronic units.
Providing hot and cold water for heating and refrigeration (radiators, underfloor heating, radiators...).

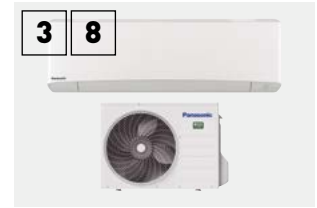

3 8 YKEA unit for server room.
Steady cooling, nonstop, even at -25 °C and still with high efficiency. Ready for continuous operation and easy to connect 2 systems to automatically alternate and ensure server rooms are kept cool.



4 AHU connection kit for efficient ventilation.
The AHU connection kit is specially designed to improve the efficiency of the pre-heating or pre-cooling ventilation process.



5 Electric VRF. ECOi EX.
ECOi electrical VRF is specifically designed for the most demanding hotels. High efficiency system. Extended operating range to provide heating at outdoor temperature as low as -25 °C (2-Pipe ECOi EX). Suitable for refurbishment projects.



6 Control your way.
Wide variety of controls, from simple user control to full system control via remote access functionality. Touch panel, web server, consumption control, smartphone control... everything is possible.



7 Wide range of indoor units.
All units provided with supply air temperature sensor and low operation sound level to guarantee maximum guest comfort. Units equipped with nanoe™ X (available in specific models) provide better air quality in public spaces in the hotel.



8 Panasonic AC Smart Cloud / Service Cloud.
Taking your business under control. The Service function makes maintenance work simpler.

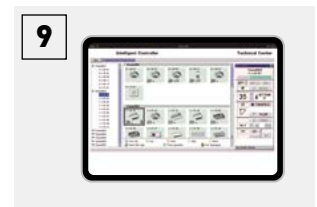

9 Protocol friendly.
Great flexibility for integration into your KNX / Modbus / LonWorks / BACnet projects allows fully bi-directional monitoring and control of all the functioning parameters.



10 Air curtain with DX coil.
The Panasonic range of air curtains is designed for smooth operation and efficient performance.



11a Condensing unit with natural refrigerant.
Panasonic CO₂ unit is the natural choice for an energy saving and environmentally friendly solution.



11b PACi NX Elite Series for cooling rooms.
High quality and efficient solution for high temperature refrigeration applications.



12 Maximum savings on hot water production.
Hot water for swimming pool, spa and laundry for free thanks to the residual heat generated by the ECO G units.

Panasonic offers the widest range in HVAC, DHW and ventilation available. That enables us to offer the most suitable solution 24 hours a day, 365 days a year. Panasonic Solutions ensure not only a higher customer satisfaction but also a lower energy bill.

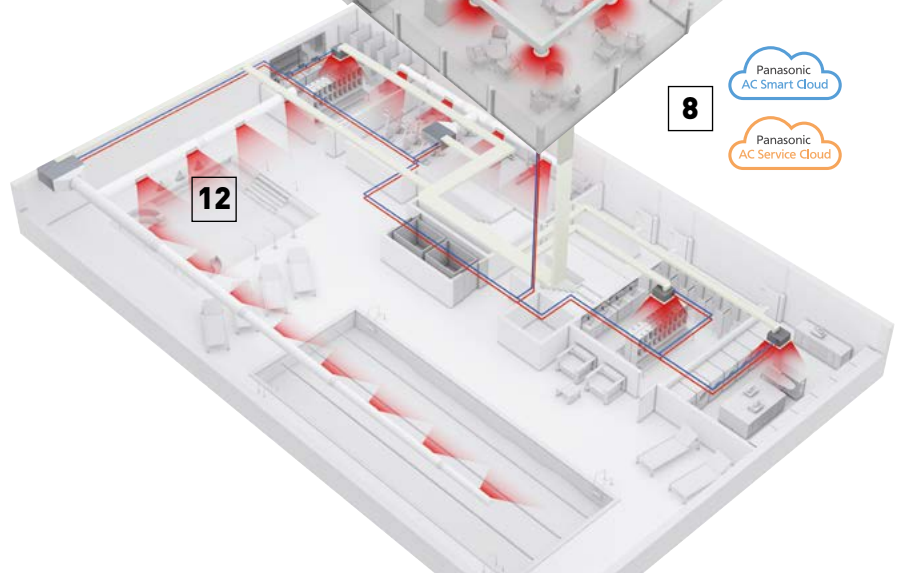
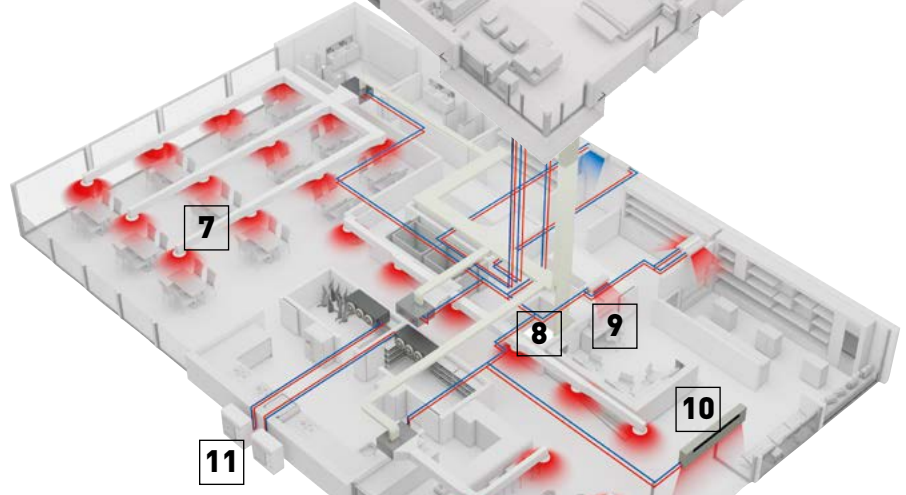
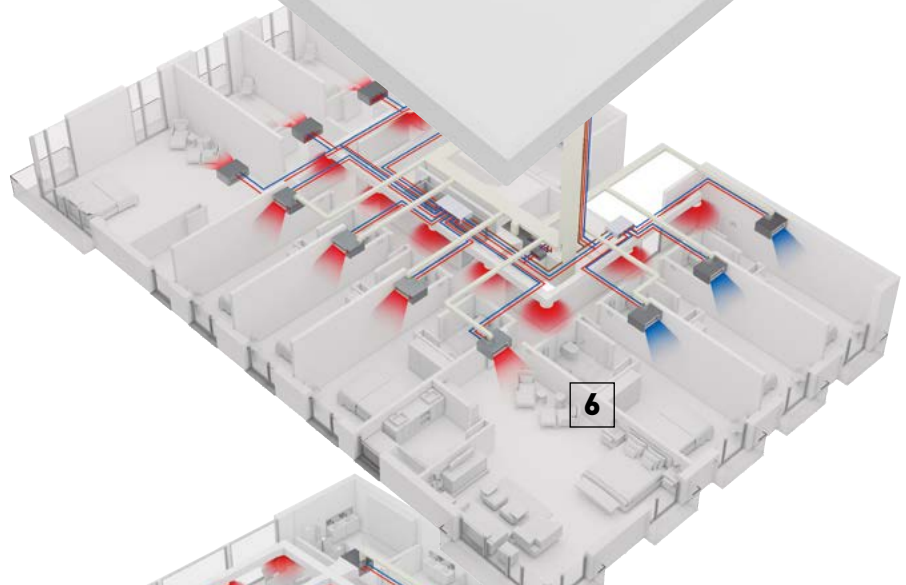
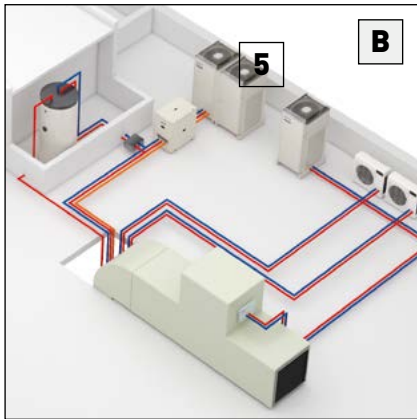
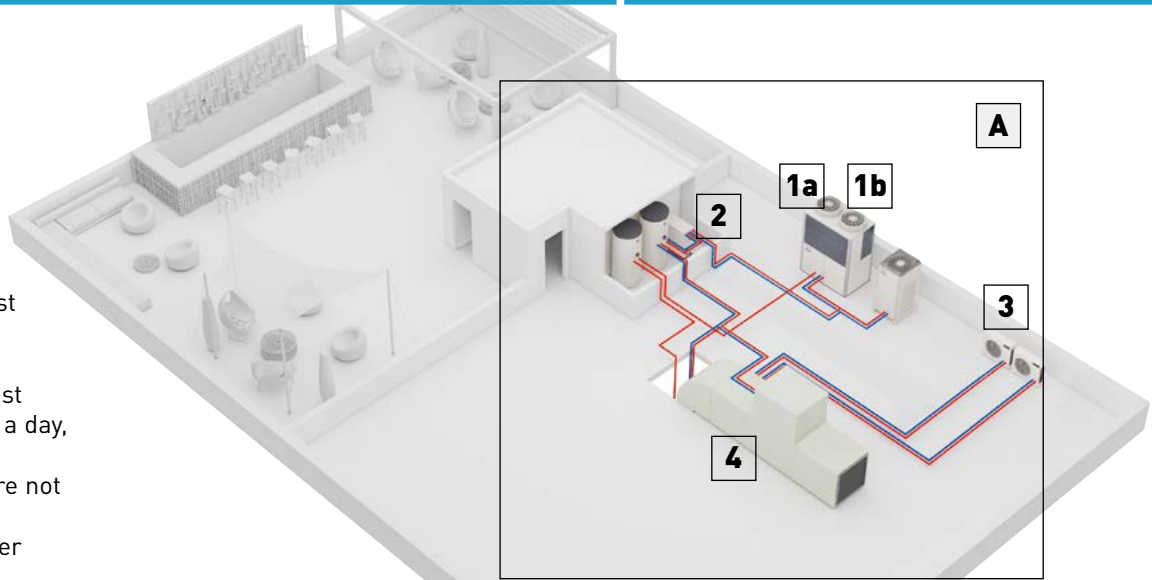

A

Option A: Hybrid solution. Gas + electric:
When large quantities of hot/cold water is needed.

- ECO G (gas heat pump)
- Water heat exchanger
- Aquarea HT to produce hot water up to 65 °C
- AHU connection kit to connect the ECO G to the AHU
- YKEA wall-mounted to cool the server rooms efficiently

B

Option B: Full Electric solution 2 and 3-Pipe. When flexibility is needed and electricity power availability is not an issue.

- ECOi (electric VRF)
- Direct expansion indoor units
- AHU connection kit to connect the ECOi to the AHU
- YKEA wall-mounted to cool the server rooms efficiently
- Panasonic Pump Down system



Innovative solutions for retail

Heating and cooling solutions for retail applications

Panasonic has developed solutions for retail and office applications where return on investment is a key factor! The comfort inside the shop is key for a good customer experience. From local control or Panasonic's cloud control system, a detailed status of the heating and cooling system can be displayed, analysed and optimised in order to improve the efficiency, reduce the running time and increase the life time of the units.

8 reason why Panasonic is the best solution for your retail:

- Complete solution
- Flexibility and adaptability
- Go green retail: low CO₂ emissions
- Comfort - high customer satisfaction
- Future expansion
- Panasonic offers efficient systems meeting expectations over the life-span of the project
- High quality of service with Panasonic pro-partner installation team
- The system will still operate down to 25% of the connected indoor units. System will not stop when only 25% of indoor units have power supply breakdown when they are on mode

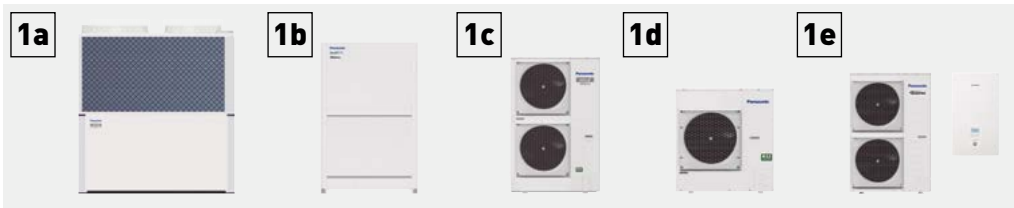

Multi energy solutions, gas or electric.

The Multi energy solution (Gas and Electric) from Panasonic provides the best choice in energy saving and on the flexibility of the installation. Panasonic solutions can be connected to direct expansion systems, water chiller installations and ventilation systems as air handling units.

- 1a: Gas VRF. ECO G
 1b: Electric VRF. ECOi
 1c: Electric VRF. Mini ECOi
 1d: Electric 1x1. PACi NX
 1e: Electric A2W. Aquarea



YKEA unit for server room.

Steady cooling, nonstop, even at -25 °C and still with high efficiency. Ready for continuous operation and easy to connect 2 systems to automatically alternate and ensure server rooms are kept cool.



Control your way.

Wide variety of controls, from simple user control to full system control via remote access functionality. Touch panel and consumption control.



Econavi Sensor.

The Econavi Sensor detects presence in the room, and quietly adapts the PACi or VRF air conditioning system in order to improve comfort and energy savings.

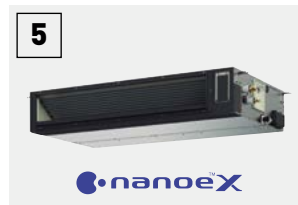

Wide range of indoor units.

All units provided with supply air temperature sensor and low operation sound level to guarantee maximum guest comfort. Units equipped with nanoe™ X (available in specific models) provide better air quality in public spaces in the hotel.

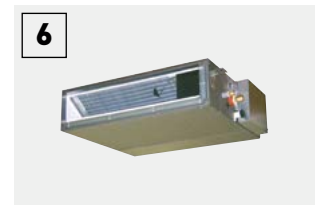

Hide-away, for power and efficiency.

Super silent units deliver the ideal air supply. Units available from 1,5 kW providing precise temperature control even in small rooms. Two models available: slim unit for height restricted areas (MM type with only 200 mm height and MF type).



Air curtain with DX coil.

The Panasonic range of air curtains is designed for smooth operation and efficient performance.



Protocol friendly.

Great flexibility for integration into your KNX / Modbus / LonWorks / BACnet projects allows fully bi-directional monitoring and control of all the functioning parameters. Range of solutions to control locally or remotely the full system in bi-directional mode.



AHU connection kit for efficient ventilation.

The AHU connection kit is specially designed to improve the efficiency of the pre-heating or pre-cooling process of the ventilation.

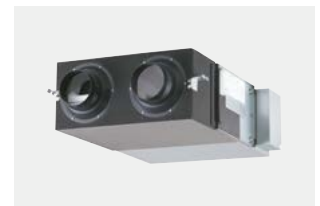





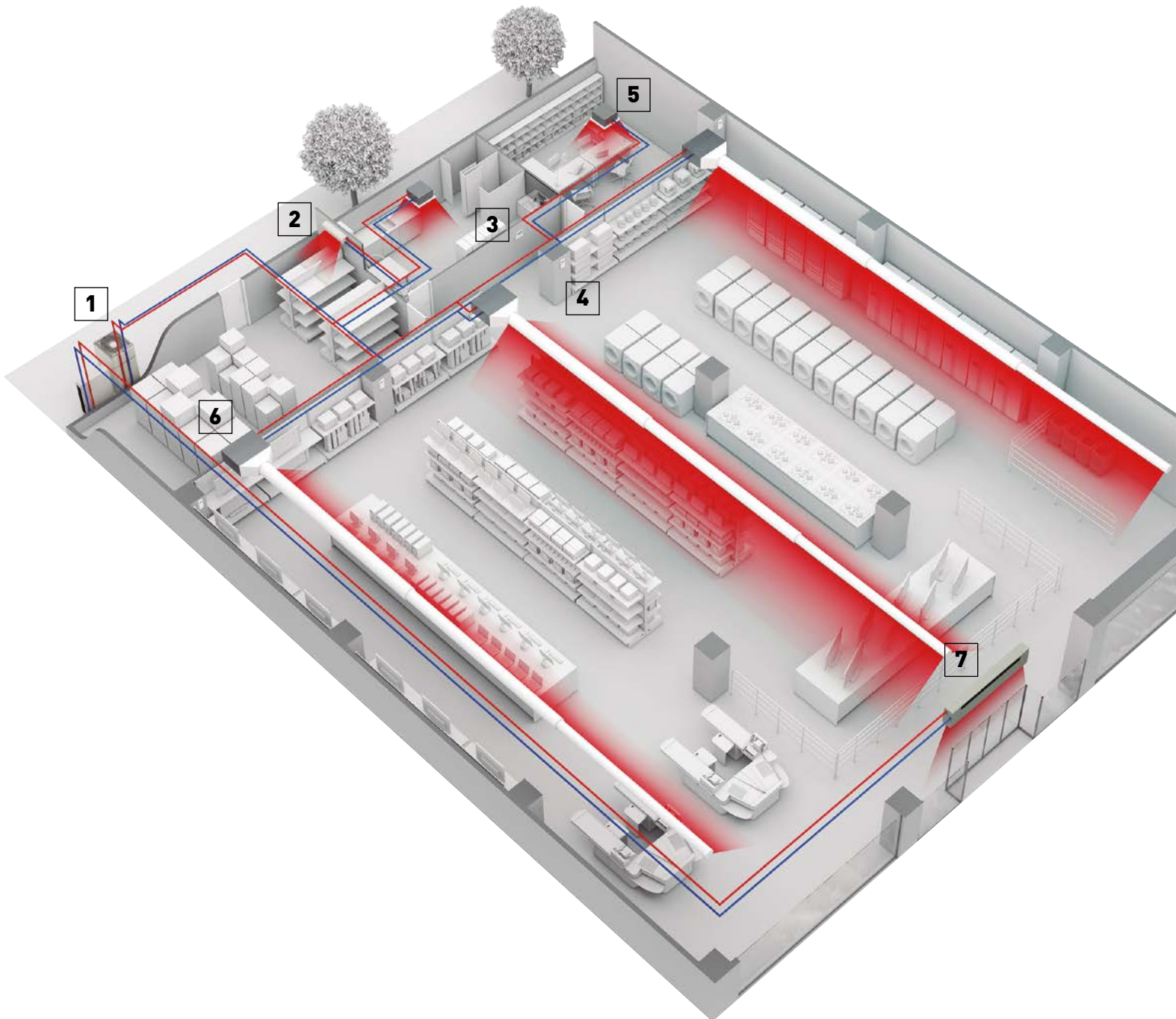











Energy Recovery unit for high efficiency of the system.

Panasonic Energy Recovery Ventilators can reduce the outside air load because they efficiently recover the heat lost by ventilation during the heat recovery process.



VRF outdoor units range

Page	Outdoor units	4 HP	5 HP	6 HP	8 HP	10 HP	12 HP
P. 254	 Mini ECOi LZ2 Series · R32						
		U-4LZ2E5 / U-4LZ2E8	U-5LZ2E5 / U-5LZ2E8	U-6LZ2E5 / U-6LZ2E8	U-8LZ2E8	U-10LZ2E8	
P. 260	Mini ECOi LE2 / LE1 Series · R410A						
		U-4LE2E5 / U-4LE2E8	U-5LE2E5 / U-5LE2E8	U-6LE2E5 / U-6LE2E8	U-8LE1E8	U-10LE1E8	
P. 272	2-Pipe ECOi EX ME2 Series · R410A						
					U-8ME2E8	U-10ME2E8	U-12ME2E8
P. 282	3-Pipe ECOi EX MF3 Series · R410A						
					U-8MF3E8	U-10MF3E8	U-12MF3E8
P. 292	2-Pipe ECO G GE3 Series · R410A						
P. 296	3-Pipe ECO G GF3 Series · R410A						
P. 298	GHP/EHP Hybrid System · R410A						



14 HP

16 HP

18 HP

20 HP

25 HP

30 HP



U-14ME2E8



U-16ME2E8



U-18ME2E8



U-20ME2E8



U-14MF3E8



U-16MF3E8



U-16GE3E5



U-20GE3E5



U-25GE3E5



U-30GE3E5



U-16GF3E5



U-20GF3E5



U-25GF3E5



U-20GES3E5 / U-10MES2E8

Best efficiency ECOi Series from Panasonic

ECOi

The ECOi Series is designed for energy savings, easy installation, and high efficiency. Always continuing to evolve, Panasonic uses advanced technologies to meet the requirements of diverse situations and contribute to the creation of comfortable living spaces.



High performance of
Panasonic's ECOi Series is
verified by Eurovent now*!

* Detailed data in page 352.

Mini ECOi LZ2 Series · R32.

The Mini ECOi LZ2 Series utilizes environmentally friendly R32 refrigerant, reducing the total amount of refrigerant by 20% and more, resulting in lower GWP, reduced by 75%*.

* As a result of applying R32 while at the same time reducing the total refrigerant amount.



Mini ECOi LE Series · R410A.

The 2-Pipe heat pump small VRF system specifically designed for the European market.



2-Pipe ECOi EX ME2 Series · R410A.

The VRF system delivering energy-saving performance, powerful operation, reliability and comfort surpassing anything previously possible.



3-Pipe ECOi EX MF3 Series · R410A.

The VRF system that offers high-efficiency and performance for simultaneous heating and cooling.



Lower running and life cycle costs.

Panasonic ECOi systems are highly efficient VRF systems, offering COPs in excess of 4,0 at full load conditions. The system is also designed to make sure that we reduce the running cost of each system by using our unique road map control routine to ensure that the efficient combination of compressors are running at any one time. Improved defrost sequencing also reduces running costs by defrosting each outdoor coil in turn when conditions allow. Up to 64 indoor units can be connected with a capacity ratio of up to 200% indexed indoor unit loads, enabling the system to be used effectively on highly diversified building loads: this large connectability feature makes it an easy-

to-design solution for schools, hotels, hospitals and other large buildings. Up to 1000 m in pipe length enables the VRF ECOi Series to be used in very large buildings, with maximum design flexibility. The ECOi system is also easy to control. It has more than 8 types of control from standard wired remote controls to touch screen panels or web access interfaces.

DC-Inverter control technology for rapid and powerful cooling and heating. The ever-evolving Panasonic ECOi Series.

ECOi Series benefits.

Ease of installation.

R410A with its higher operating pressure and lower pressure loss allows for smaller pipe sizes to be used with reduced refrigerant charge.

Simple to design.

Panasonic recognise that designing, selecting and preparing a professional VRF quotation can be a time consuming and costly process, especially as it is often also a speculative exercise. So we have designed proprietary software which is quick and easy to use and produces a full schematic layout of pipework and controls, as well as a full materials list with supporting performance data.

Easy to control.

A wide variety of control options are available to ensure that the ECOi system provides the user with the degree of control that they desire, from simple room controllers through to state of the art BMS controls.

Simple to commission.

Simple set-up procedure including automatic addressing of connected indoor units. Configuration settings can be made from an outdoor unit or via a remote controller.

Easy to position.

The compact design of the ECOi outdoor units means that sizes 4 HP to 10 HP fit into a standard lift and are easy to handle and position when on site. The small footprint and modular appearance of the units ensure a cohesive appearance to an installation.

Wide selection and connectability.

With 17 indoor model styles available, ECOi systems are the ideal choice for multiple small capacity indoor unit installations, with the ability to connect up to 40 indoor units to systems of 24 HP or greater for 3-Pipe ECOi EX MF3 Series.

Easy to maintain.

Each system allows the use of prognostic and diagnostic controls routines, to manage system operation and identifying faults, all designed to reduce the speed of maintenance calls and unit down time.

Mini ECOi LZ2 Series R32

ECO i

Outstanding efficiency in a compact body and continuous operation even at extreme ambient temperatures.



Industry 1st 8 HP and 10 HP
Mini VRF units with R32



4 / 5 / 6 HP



8 / 10 HP



1 Low GWP and less refrigerant

The Mini ECOi LZ2 Series utilizes environmentally friendly R32 refrigerant, reducing the total amount of refrigerant by 20% and more, resulting in lower GWP, reduced by 75%*.

* As a result of applying R32 while at the same time reducing the total refrigerant amount.

2 Outstanding efficiency at the most challenging ambient conditions

Re-engineered for better performance, the LZ2 series produces extraordinary savings with SEER levels up to 8,5 and SCOP levels up to 5,0 (for 4 HP model). The large range of outdoor units from 12 kW to 28 kW can also work at extreme ambient temperatures, down to -20 °C in heating and up to 52 °C in cooling, providing a very wide range of operating ability.

3 More flexibility for your project

The ECOi LZ2 series provides ease of installation with long piping lengths and small footprints in a lightweight body. A variety of indoor units, supporting Panasonic's optional R32 refrigerant leak detector, increases the flexibility for installers. A wide range of individual and central controllers, AC Smart Cloud and Service Cloud, as well as apps for end users and installers, provide a fully customizable monitoring and controlling solution.

Minimum environmental impact.

Panasonic has designed the LZ2 series in order to minimize the environmental impact of the system. Low GWP refrigerant R32 and highest efficiency levels ensure this through the total operational lifetime.



VRF with outstanding energy-saving performance and superior SEER and SCOP

Mini ECOi LZ2 provides the optimal performance in any climatic condition.

Wide operating range
-20 °C in heating to
52 °C in cooling

8,5 SEER | 5,0 SCOP
Extraordinary savings

ECOi LZ2 mini VRF series from 12 to 28 kW

- Improving protection 24/7. Unique indoors with nanoe™ X, hydroxyl radicals contained in water
- SEER levels up to 8,5 and SCOP levels up to 5,0 (for 4 HP model)
- Low GWP and highly reduced refrigerant volume
- Improved connectivity with CONEX remote controllers and app support, Smart and Service Cloud applications and support for communication protocols for BMS integration
- Wide range of connectable units allowing wide range of installations with and without refrigerant mitigation
- Increased indoor / outdoor capacity ratio up to 150%
- Quiet mode operation with low capacity drop
- Same Panasonic DNA with Panasonic compressors and precise temperature control thanks to discharge temperature sensors in the indoor units
- Continuous operation at extreme ambient temperatures: -20 °C (heating) to 52 °C (cooling)
- Flexible mitigation measures, with Panasonic R32 refrigerant leak detector / alarm to be installed only when required
- 35 Pa static pressure

For the most challenging spaces

The Mini ECOi LZ2 R32 VRF system is the ideal solution to fit into any application thanks to its compact design and long piping length support.

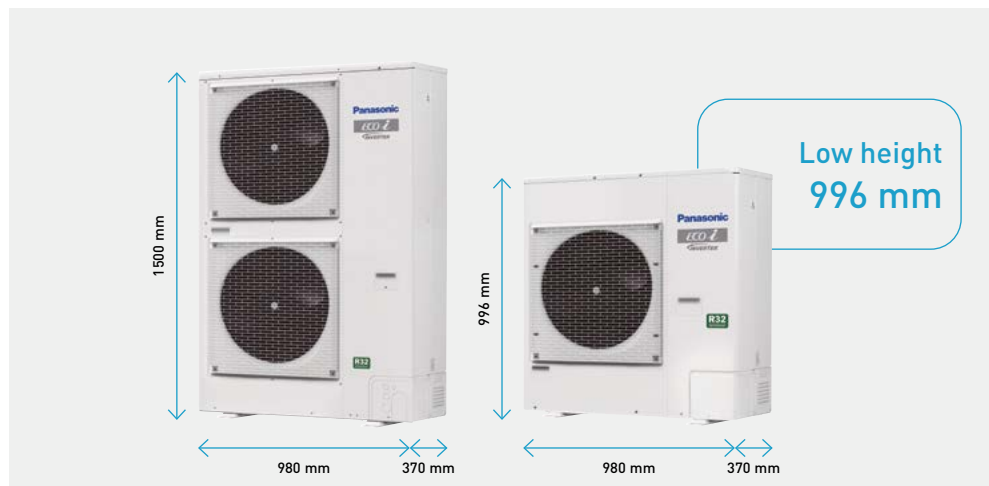

Extended design operation conditions

LZ2 mini VRF is extremely reliable even under the most difficult conditions. The units can operate in cooling mode at extreme temperatures, 52 °C in cooling and -20 °C in heating mode.

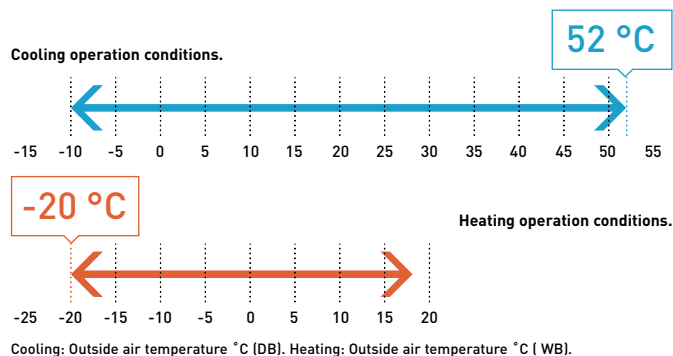











Compatible with a large range of indoor units and controls

An expansion of Panasonic VRF line up, the Mini ECOi R32 is compatible with a large range of indoor units and can utilize all Panasonic's scalable control and monitoring solutions.

Wide range of indoor units, either supporting Panasonic's optional R32 refrigerant leak detector alarm or having built-in detectors provide a great flexibility for all types of installation.

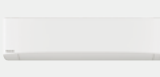
Scaling your control options from a single zone to geographically distributed facilities.

LZ2 series are fully compatible with all control and connectivity solutions from Panasonic. With a wide range of individual controllers, hotel room controllers, optional wireless adapters, VRF Smart Connectivity+, easy BMS connection with S-Link and Panasonic AC Smart Cloud compatibility. LZ2 series, the most flexible control and monitoring R32 solution in the market.

	4 way 90x90 cassette		Connects Panasonic R32 sensor
	4 way 60x60 cassette		Connects Panasonic R32 sensor
	Variable static pressure adaptive duct		Built-in R32 sensors
	Wall-mounted		Connects Panasonic R32 sensor
	Slim variable static pressure hide-away		Connects Panasonic R32 sensor

Panasonic R32 refrigerant leak detector/alarm (optional)

For compatible indoor unit models, Panasonic offers its optional external Panasonic R32 refrigerant leak detector (CZ-CGLSC1). This enables the customer to decide if a Panasonic R32 refrigerant leak detector is required to comply with the restrictions, or if the indoor unit may be safely installed in this room without it. This optional leakage detection sensor has an integrated alarm buzzer and can output a signal to a central alarm system in the building. The device is connected to the remote control terminals of the indoor unit and can be used in combination with any of the Panasonic VRF remote controllers, either wired or wireless.

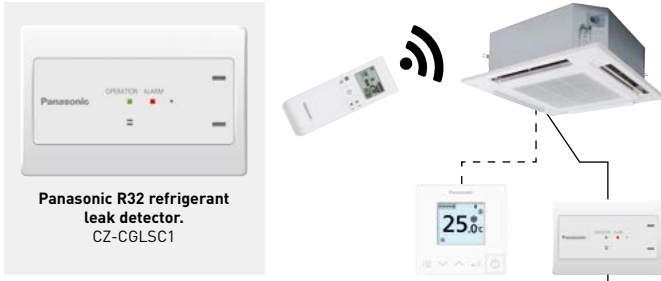

Panasonic R32 refrigerant leak detector. CZ-CGLSC1

The alarm triggered by the Panasonic R32 refrigerant leak detector will also be transmitted and displayed on any connected centralised controller.

* Only one remote controller can be connected with the Panasonic R32 refrigerant leak detector.

5 V external output (central monitoring etc.)

R32 Pump Down solution

R32 Pump Down solution offers the assurance of additional safety protection, whilst expanding the potential installation cases, allowing for installation within smaller rooms.

Suitable for the Mini ECOi LZ2 range up to 10 HP, compatible indoor units connected to CZ-CGLSC1 or integrated Panasonic R32 refrigerant leak detector.

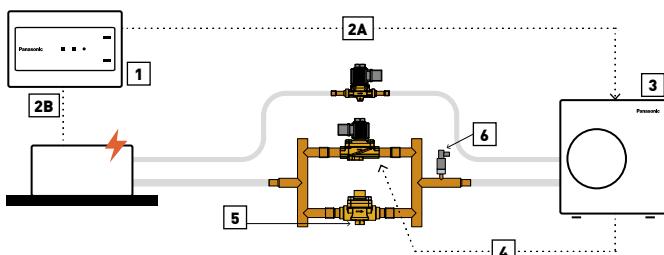

Operation steps: 1 | A leak is detected by the leak detection sensor. 2A | Leak alarm signal is sent to the outdoor unit. 2B | Indoor unit fan activated and runs at maximum speed. 3 | Pump Down procedure is activated. 4 | Solenoid valves are closed preventing refrigerant returning to indoor units. 5 | Outdoor unit is operating in Pump Down mode and check valve only allows flow to the outdoor unit. 6 | Low pressure switch threshold is reached. Error signal isolates the outdoor unit, preventing restart.

Technical focus

- Simplified design and installation
- Complies with IEC 60335-2-40 ed.6.0
- Recovers base charge within outdoor unit
- Expands potential installation cases
- IP rated connections for outdoor installation

Model reference	Description
PAW-PUD2WB-1	Basic Pump Down system (2 way) for one R32 Mini ECOi outdoor unit

Pump Down kit.
Indication of the items included within the Pump Down kit.

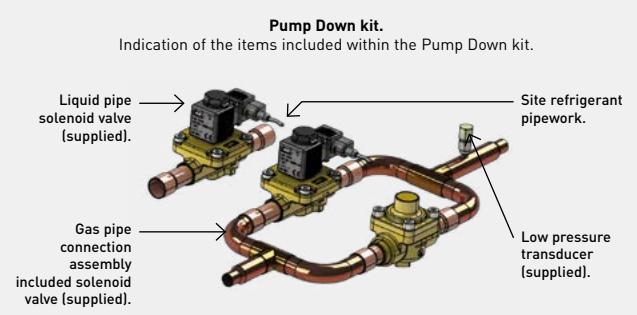

- Liquid pipe solenoid valve (supplied).
- Gas pipe connection assembly included solenoid valve (supplied).
- Site refrigerant pipework.
- Low pressure transducer (supplied).

Mini ECOi LZ2 Series 4 to 6 HP · R32

Outstanding efficiency in a compact body and continuous operation even at extreme ambient temperatures.

- SEER levels up to 8,5 and SCOP levels up to 5,0 (for 4 HP model)
- Continuous operation at extreme ambient temperatures: -20 °C (heating) to 52 °C (cooling)
- Wide range of connectable units
- Unique indoors with nanoe™ X, hydroxyl radicals contained in water
- Allowing wide range of installations with and without mitigation measures
- Flexible mitigation measures, with Panasonic R32 refrigerant leak detector / alarm to be installed only when required

Low height
996 mm



HP			4 HP	5 HP	6 HP	4 HP	5 HP	6 HP
Outdoor unit			U-4LZ2E5	U-5LZ2E5	U-6LZ2E5	U-4LZ2E8	U-5LZ2E8	U-6LZ2E8
Power supply	Voltage	V	220-230-240	220-230-240	220-230-240	380-400-415	380-400-415	380-400-415
	Phase		Single phase	Single phase	Single phase	Three phase	Three phase	Three phase
	Frequency	Hz	50	50	50	50	50	50
Cooling capacity		kW	12,1	14,0	15,5	12,1	14,0	15,5
EER ¹⁾		W/W	4,53	4,12	3,88	4,53	4,12	3,88
Current		A	13,30-12,80-12,20	16,90-16,20-15,50	19,60-18,70-18,00	4,37-4,15-4,00	5,50-5,23-5,04	6,44-6,12-5,89
Input power		kW	2,67	3,40	4,00	2,67	3,40	4,00
Heating capacity		kW	12,5	16,0	16,5	12,5	16,0	16,5
COP ¹⁾		W/W	5,27	4,71	4,42	5,27	4,71	4,42
Current		A	12,00-11,40-11,00	16,90-16,20-15,50	18,50-17,70-17,00	3,91-3,71-3,58	5,50-5,22-5,03	6,02-5,72-5,51
Input power		kW	2,37	3,40	3,73	2,37	3,40	3,73
Starting current		A	1,0	1,0	1,0	1,0	1,0	1,0
Maximum current		A	19,6	23,7	26,5	7,2	9,2	9,9
Maximum input power		kW	3,92-4,10-4,28	4,76-4,98-5,19	5,41-5,66-5,90	4,40-4,63-4,80	5,69-5,99-6,22	6,15-6,47-6,72
Maximum number of connectable indoor units ²⁾			7(10)	8(12)	9(12)	7(10)	8(12)	9(12)
External static pressure		Pa	0-35	0-35	0-35	0-35	0-35	0-35
Air flow		m ³ /min	69	72	74	69	72	74
Sound pressure	Cool	dB(A)	52	53	54	52	53	54
	Cool (Silent 1/2/3/4)	dB(A)	49/47/45/45	50/48/46/45	51/49/47/45	49/47/45/45	50/48/46/45	51/49/47/45
Sound power	Heat	dB(A)	54	56	56	54	56	56
	Cool / Heat	dB(A)	69/72	70/74	72/75	69/72	70/74	72/75
Dimension	HxWxD	mm	996x980x370	996x980x370	996x980x370	996x980x370	996x980x370	996x980x370
Net weight		kg	94	94	94	94	94	94
Piping diameter	Liquid	Inch (mm)	3/8(9,52)	3/8(9,52)	3/8(9,52)	3/8(9,52)	3/8(9,52)	3/8(9,52)
	Gas	Inch (mm)	5/8(15,88)	5/8(15,88)	5/8(15,88)	5/8(15,88)	5/8(15,88)	5/8(15,88)
Maximum piping length (total)		m	90(180)	90(180)	90(180)	90(180)	90(180)	90(180)
Elevation difference (in / out)		m	50(OU above)/ 40(OU below)	50(OU above)/ 40(OU below)	50(OU above)/ 40(OU below)	50(OU above)/ 40(OU below)	50(OU above)/ 40(OU below)	50(OU above)/ 40(OU below)
Refrigerant (R32)		kg	2,7	2,7	2,7	2,7	2,7	2,7
Maximum allowable indoor / outdoor capacity ratio ³⁾		%	50-150(130)	50-150(130)	50-150(130)	50-150(130)	50-150(130)	50-150(130)
Operating range	Cool Min - Max	°C	-10-52	-10-52	-10-52	-10-52	-10-52	-10-52
	Heat Min - Max	°C	-20-18	-20-18	-20-18	-20-18	-20-18	-20-18

ErP data ⁴⁾								
SEER ⁵⁾			8,50	8,12	7,71	8,50	8,12	7,71
$\eta_{s,c}$			337,0%	321,8%	305,4%	337,0%	321,8%	305,4%
SCOP ⁵⁾			5,05	4,61	4,59	5,05	4,61	4,59
$\eta_{s,h}$			199,0%	181,4%	180,6%	199,0%	181,4%	180,6%

1) EER and COP calculation is based on EN 14511. 2) The number in parenthesis indicates maximum number of connectable indoor unit in case of 1,5 kW indoor units connection. 3) The number in parenthesis indicates maximum allowed indoor / outdoor capacity ratio in case of 1,5 kW indoor units connection. 4) SEER / SCOP and $\eta_{s,c}$ / $\eta_{s,h}$ are in accordance with ErP test data for U2 type 4 way 90x90 cassette indoor units. 5) SEER / SCOP is calculated based on the seasonal space cooling / heating efficiency "η" values of the COMMISSION REGULATION (EU) 2016/2281. SEER, SCOP = (η + Correction) × PEF.

Minimum environmental impact

Panasonic has designed the LZ2 series in order to minimize the environmental impact of the system. Low GWP refrigerant R32 and highest efficiency levels ensure this through the total operational lifetime.

For the most challenging spaces

The Mini ECOi LZ2 R32 VRF system is the ideal solution to fit into any application thanks to its compact design and long piping lengths.



INTERNET CONTROL: Optional.



Mini ECOi LZ2 Series 8 and 10 HP · R32

Introducing widest range of R32 Mini VRF.

- SEER levels up to 7,6 and SCOP levels up to 4,6 (for 8 HP model)
- Continuous operation at extreme ambient temperatures: -20 °C (heating) to 52 °C (cooling)
- Widest range of connectable units in R32 VRF
- Unique indoors with nanoe™ X, hydroxyl radicals contained in water
- Allowing wide range of installations with and without refrigerant mitigation
- Flexible mitigation measures, with Panasonic R32 refrigerant leak detector / alarm to be installed only when required

Industry 1st
8 HP and 10 HP
Mini VRF units
with R32

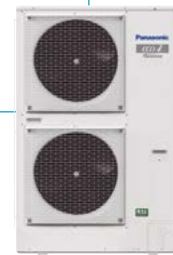

HP			8 HP	10 HP
Outdoor unit			U-8LZ2E8	U-10LZ2E8
Power supply	Voltage	V	380-400-415	380-400-415
	Phase		Three phase	Three phase
	Frequency	Hz	50	50
Cooling capacity		kW	22,4	28,0
EER ¹⁾		W/W	3,84	3,47
Current		A	9,73 - 9,25 - 8,91	13,2 - 12,5 - 12,1
Input power		kW	5,83	8,07
Heating capacity		kW	25,0	28,0
COP ¹⁾		W/W	4,30	4,47
Current		A	9,81 - 9,32 - 8,98	10,5 - 9,93 - 9,57
Input power		kW	5,81	6,26
Starting current		A	1,0	1,0
Maximum current		A	13,7	19,5
Maximum input power		kW	8,21 - 8,64 - 8,96	11,9 - 12,6 - 13,0
Maximum number of connectable indoor units ²⁾			16	16
External static pressure		Pa	0 - 35	0 - 35
Air flow		m ³ /min	158	167
Sound pressure	Cool	dB(A)	59,0	60,0
	Cool (Silent 1/2/3/4)	dB(A)	56/54/52/50	57/55/53/50
Sound power	Cool	dB(A)	72	74
Dimension	H x W x D	mm	1500 x 980 x 370	1500 x 980 x 370
Net weight		kg	125	126
Piping diameter	Liquid	Inch (mm)	3/8(9,52)	3/8(9,52)
	Gas	Inch (mm)	3/4(19,05)	7/8(22,22)
Maximum piping length (total)		m	100(300)	100(300)
Elevation difference (in / out)		m	50(OU above)/40(OU below)	50(OU above)/40(OU below)
Refrigerant (R32)		kg	4,9	5,1
Maximum allowable indoor / outdoor capacity ratio ³⁾		%	50 - 150(130)	50 - 150(130)
Operating range	Cool Min ~ Max	°C	-10 - 52	-10 - 52
	Heat Min ~ Max	°C	-20 ~ 18	-20 ~ 18

ErP data⁴⁾

SEER ⁵⁾	7,56	7,08
$\eta_{s,c}$	299,4%	280,2%
SCOP ⁵⁾	4,59	4,60
$\eta_{s,h}$	180,6%	181,0%

1) EER and COP calculation is based on EN 14511. 2) The number in parenthesis indicates maximum number of connectable indoor unit in case of 1,5 kW indoor units connection. 3) The number in parenthesis indicates maximum allowed indoor / outdoor capacity ratio in case of 1,5 kW indoor units connection. 4) SEER / SCOP and $\eta_{s,c}$ / $\eta_{s,h}$ are in accordance with ErP test data for F2 type variable static pressure hide-away indoor units. 5) SEER / SCOP is calculated based on the seasonal space cooling / heating efficiency "η" values of the COMMISSION REGULATION (EU) 2016/2281. SEER, SCOP = (η + Correction) × PEF.

Perfect fit for small to medium size projects

8 and 10 HP LZ2 Mini VRF units bring in the total benefits of a VRF system in a smaller application. You can enjoy advanced individual and central VRF control options including the revolutionary Panasonic AC Smart Cloud and AC Service Cloud.

For the most difficult conditions

The Mini ECOi LZ2 series are able to operate at the hardest conditions from -20 °C up to +52 °C providing continuous and efficient, heating and cooling for your space all year long.



INTERNET CONTROL: Optional.



Mini ECOi LE Series for light commercial and residential use

ECOi

Mini ECOi with extraordinary energy-saving performance and high external static pressure (35Pa).

Compact design



7,9
SEER4,9*
SCOPIndustry leading
efficiency

4 / 5 / 6 HP

6,4*
SEER4,3
SCOP

8 / 10 HP

1 Efficiency energy control

Upgraded outdoor units deliver high efficiency rating and reduced energy costs.

2 Space saving

Ideal for commercial locations with limited space such as banks and shops.

Compact units integrate easily and discreetly into building design.

3 Flexible installation

Reduced installation time thanks to compact units and extra long piping without additional refrigeration charge. High external static pressure 35 Pa and small chassis increase installation options.

Compact design: LE2 Series - 4 / 5 / 6 HP

- Extraordinary energy saving: 7,9 SEER and 4,9 SCOP (4 HP)*
- 50 m piping length without additional refrigerant charge
- Quiet operation mode with 4 levels
- High COP mode option

* SEER / SCOP is calculated based on the seasonal space cooling / heating efficiency "η" values of the COMMISSION REGULATION (EU) 2016/2281. SEER, SCOP = (η + Correction) × PEF.

LE1 Series - 8 / 10 HP

- 60% smaller than ECOi ME2 8 / 10 HP vertical flow type
- Flexible piping length (Total: 300 m, Furthest: 150 m)
- Maximum number of connectable indoor units: 15

Key features for LE2 / LE1.

- High external static pressure 35 Pa
- Full range of ECOi indoor units and controllers
- Variable evaporation temperature control as standard
- Connectable maximum indoor / outdoor capacity ratio up to 130%
- Auto restart from outdoor units
- Demand response (Peak cut) by optional parts
- Suitable for R22 renewable projects



Flexible, easy and hassle free installation

Compact space-saving design. High external static pressure 35 Pa. Long piping length for flexible installation. No additional refrigerant charge up to 50 m. 130% capacity ratio for connectable indoor units.

High external static pressure 35 Pa

- High air pressure
- An efficient blade design
- Perfect for high class condominiums

When unit is installed on a narrow balcony and exposed to the sun, the barrier at the front side may restrict hot air from being discharged. Heat accumulated in an enclosure can cause over-heating. This may potentially result in damage or shorten the product's life span. A high external static pressure fan sends the air further away from the outdoor unit and through the barrier. This provides better air circulation and distribution. And a high air pressure of 35 Pa discharges the hot air to a sufficient distance.

Previous model - low pressure.

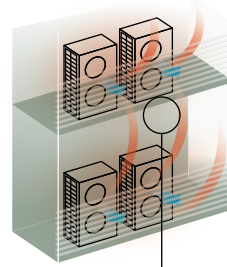

Heat accumulated.
When the pressure is low, hot air will accumulate in the unit thus affecting its work performance and that of unit above it as well.



LE Series - high pressure.

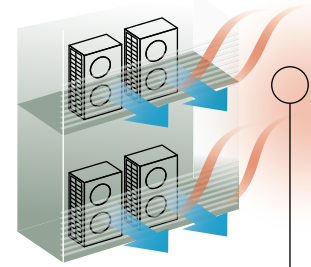

Heat discharged.
But with a high pressure of 35 Pa, hot air is sent further away preventing overheating inside the outdoor unit enclosure.



Long piping design length for greater design flexibility

LE1: Maximum total piping length: 300 m.
LE2: Maximum total piping length: 180 m.

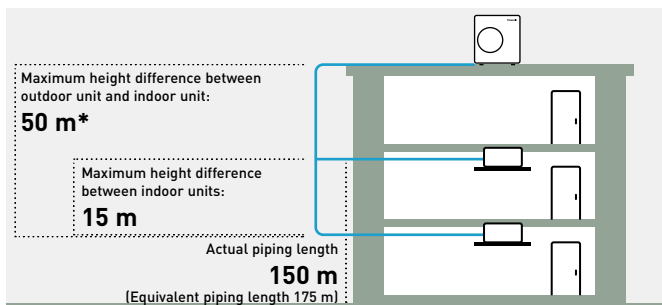

* 40 m if the outdoor unit is below the indoor unit.

Plug & Play concept

- 50 m piping length free of charge
- A 50 m pipe length is sufficient for most residential and small business buildings

Free of charge
50 m

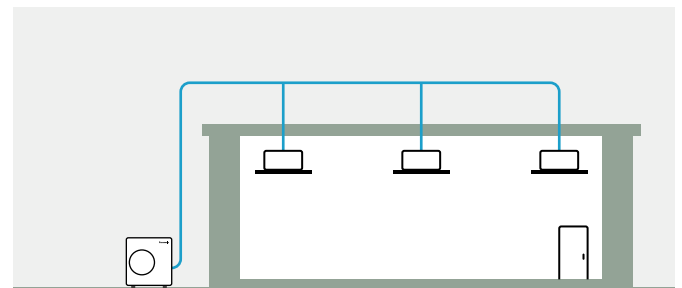

Connection of up to 15 indoor units

An expansion from Panasonic VRF line up, the mini ECOi is compatible with the same indoor units and controls as the rest of the ECOi range.

Compact design

Mini ECOi LE Series is a single unit.

Perfect for installations with limited space and easy to hide within a modern building. Flexible space-saving options compared to single split system.

LE2 low height of 996 mm.

LE2 Series is 25% smaller in height than conventional model.



Energy control and reliability

The Mini ECOi system delivering energy-saving performance, powerful operation, reliability and comfort surpassing anything previously possible.

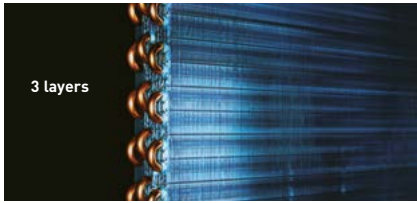

Powerful heat exchanger.
3 layers of heat exchanger for all LE Series. LE Series features the same heat exchange volume as conventional model even though it is 15% smaller in size.

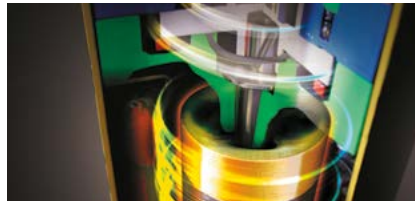

Panasonic twin rotary compressor.
A large capacity Inverter compressor has been adopted. This compressor features wider and 0,1 Hz step Inverter control.



Design fan.
Fan blades have been redesigned to inhibit air resistance and to increase efficiency. The larger fan increases air flow while maintaining low noise levels.

Energy savings design

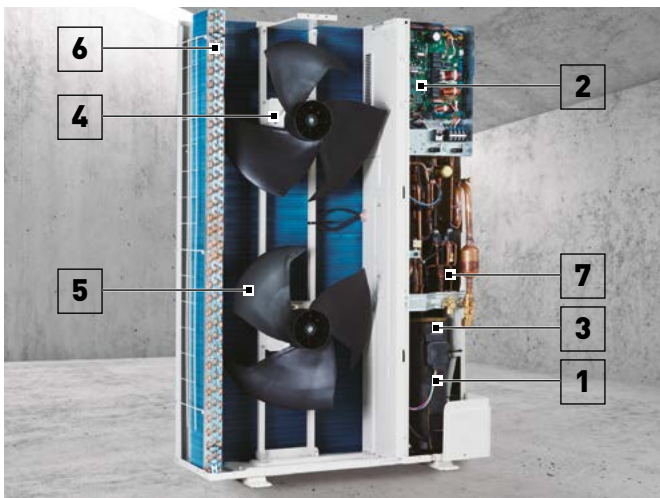

- 1 | **Panasonic Inverter compressor.** A large-capacity Inverter compressor has been adopted. The Inverter compressor is superior in performance with improved partial-load capacity.
- 2 | **Printed circuit board.** Maintenance is made easier with only 2 PCBs.
- 3 | **Accumulator.** A large accumulator has been adopted to maintain compressor reliability because of the increased refrigerant quantity, which allows an extended maximum piping length.
- 4 | **DC fan motor.** Checking load and outside temperature, the DC motor is controlled for optimum air flow.
- 5 | **Blade shape.** The fan blades have been developed to inhibit air turbulence and increase efficiency. As the fan diameter has been increased, air flow has also increased whilst maintaining a same sound level.
- 6 | **Heat exchanger and copper tubes.** The heat exchanger size and the copper tube sizes in the heat exchanger have been redesigned to increase efficiency.
- 7 | **Oil separator.** A centrifugal separator has been adopted to improve oil separation efficiency and reduce refrigerant pressure loss.

Bluefin condenser: high durability outdoor unit

The anti-corrosion Bluefin treatment of the heat exchanger provides greater resistance against corrosion. All models are equipped with Bluefin condenser and corrosion-resistance treated for high resistance to rust and salty air to assure long-lasting performance.

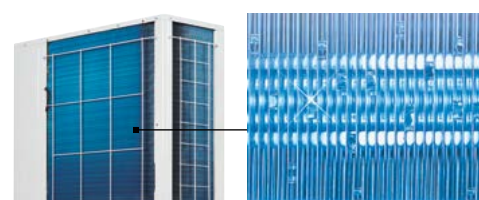

Heat exchanger (Bluefin condenser)

Maximum comfort with quiet operation mode

- Quiet operation mode reduces outdoor unit operating sound by 7 dB(A)
- 4-step set point is available
- Silent mode 1 maintains rated cooling capacity

* Timer setting of quiet operation mode is available in High-spec remote controller.

Silent mode options	Sound pressure level
Silent mode 1	-1,5 dB(A)
Silent mode 2	-3 dB(A)
Silent mode 3	-5 dB(A)
Silent mode 4	-7 dB(A)

SEER / SCOP

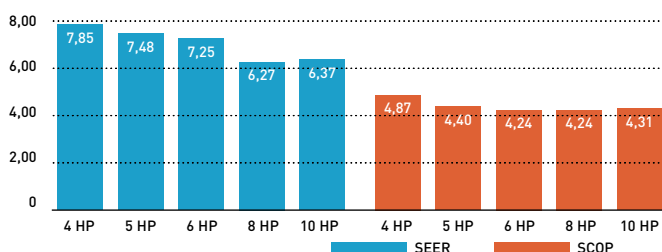

Superior seasonal energy efficiency (SEER / SCOP follows LOT21*)

The operation efficiency has been improved using highly efficient R410A refrigerant, a DC Inverter compressor, DC motor and a heat exchanger design.

* SEER / SCOP is calculated based on the seasonal space cooling / heating efficiency "η" values of the COMMISSION REGULATION (EU) 2016/2281. SEER, SCOP = (η + Correction) × PEF.

Mini ECOi LE2 Series high efficiency 4 to 6 HP · R410A

Panasonic Mini ECOi. Extraordinary energy-saving.

The most compact ECOi system ever.

- Outstanding SEER and SCOP
- Better efficiency even compared to 2 fan outdoor units
- 50 m piping without additional refrigeration charge
- High static pressure 35 Pa
- High COP mode selectable with maintenance remote controller
- Selectable silent mode



HP			4 HP	5 HP	6 HP	4 HP	5 HP	6 HP
Outdoor unit			U-4LE2E5	U-5LE2E5	U-6LE2E5	U-4LE2E8	U-5LE2E8	U-6LE2E8
Power supply	Voltage	V	220-230-240	220-230-240	220-230-240	380-400-415	380-400-415	380-400-415
	Phase		Single phase	Single phase	Single phase	Three phase	Three phase	Three phase
	Frequency	Hz	50	50	50	50	50	50
Cooling capacity		kW	12,1	14,0	15,5	12,1	14,0	15,5
EER ¹⁾		W/W	4,50	4,06	3,73	4,50	4,06	3,73
Current		A	13,30-12,70-12,20	16,30-15,60-17,00	20,30-19,40-18,60	4,39-4,17-4,02	5,58-5,30-5,11	6,71-6,37-6,14
Input power		kW	2,69	3,45	4,15	2,69	3,45	4,15
Heating capacity		kW	12,5	16,0	16,5	12,5	16,0	16,5
COP ¹⁾		W/W	5,19	4,60	4,27	5,19	4,60	4,27
Current		A	12,20-11,60-11,20	17,60-16,80-16,10	19,10-18,20-17,50	3,98-3,78-3,64	5,62-5,34-5,14	6,24-5,93-5,71
Input power		kW	2,41	3,48	3,86	2,41	3,48	3,86
Starting current		A	1,00	1,00	1,00	1,00	1,00	1,00
Maximum current		A	17,30	24,30	27,40	7,90	10,10	10,70
Maximum input power		kW	3,50-3,66-3,82	4,92-5,14-5,37	5,61-5,86-6,12	4,34-5,09-5,28	6,25-6,55-6,82	6,62-6,97-7,23
Maximum number of connectable indoor units ²⁾			7(10)	8(10)	9(12)	7(10)	8(10)	9(12)
External static pressure		Pa	0-35	0-35	0-35	0-35	0-35	0-35
Air flow		m ³ /min	69	72	74	69	72	74
Sound pressure	Cool	dB(A)	52	53	54	52	53	53
	Cool (Silent 1/2/3/4)	dB(A)	50,5/49/47/45	51,5/50/48/46	52,5/51/48/46	50,5/49/49/47	48,5/50/48/46	48,5/50/48/46
Sound power	Heat	dB(A)	54	56	56	54	56	56
	Cool / Heat	dB(A)	69/72	71/75	73/75	69/72	71/75	73/75
Dimension	HxWxD	mm	996x980x370	996x980x370	996x980x370	996x980x370	996x980x370	996x980x370
Net weight		kg	106	106	106	106	106	106
Piping diameter	Liquid	Inch (mm)	3/8(9,52)	3/8(9,52)	3/8(9,52)	3/8(9,52)	3/8(9,52)	3/8(9,52)
	Gas	Inch (mm)	5/8(15,88)	5/8(15,88)	5/8(15,88)	5/8(15,88)	5/8(15,88)	5/8(15,88)
Maximum piping length (total)		m	150(180)	150(180)	150(180)	150(180)	150(180)	150(180)
Elevation difference (in / out)		m	50(OU above)/ 40(OU below)	50(OU above)/ 40(OU below)	50(OU above)/ 40(OU below)	50(OU above)/ 40(OU below)	50(OU above)/ 40(OU below)	50(OU above)/ 40(OU below)
Refrigerant (R410A) / CO ₂ Eq.		kg / T	6,70(14,40)/ 13,9896	6,70(14,40)/ 13,9896	6,70(14,40)/ 13,9896	6,70(14,40)/ 13,9896	6,70(14,40)/ 13,9896	6,70(14,40)/ 13,9896
Maximum allowable indoor / outdoor capacity ratio		%	50-130	50-130	50-130	50-130	50-130	50-130
Operating range	Cool Min - Max	°C	-10 ~ +46	-10 ~ +46	-10 ~ +46	-10 ~ +46	-10 ~ +46	-10 ~ +46
	Heat Min - Max	°C	-20 ~ +18	-20 ~ +18	-20 ~ +18	-20 ~ +18	-20 ~ +18	-20 ~ +18

ErP data³⁾

SEER ⁴⁾	7,85	7,48	7,25	7,85	7,48	7,25
$\eta_{s,c}$	311,0%	296,2%	286,8%	311,0%	296,2%	286,8%
SCOP ⁴⁾	4,87	4,40	4,24	4,87	4,40	4,24
$\eta_{s,h}$	191,8%	172,9%	166,7%	191,8%	172,9%	166,7%

1) EER and COP calculation is based in accordance to EN14511. 2) In case of 1.5 kW indoor units connection, able to connect maximum 12 indoor units. 3) SEER / SCOP and $\eta_{s,c}$ / $\eta_{s,h}$ are in accordance with ErP test data for F2 type variable static pressure hide-away indoor units. 4) SEER / SCOP is calculated based on the seasonal space cooling / heating efficiency "η" values of the COMMISSION REGULATION (EU) 2016/2281. SEER, SCOP = (η + Correction) × PEF.

For light commercial use

Mini ECOi allows easier installation in condominiums and medium sized buildings with limited spaces. Utilising R410A and DC Inverter technology, Panasonic offers VRF to a new and growing market.

Reduced height of 996 mm

In addition to raising efficiency, the outdoor unit has been designed to be as compact as possible. It can now be installed in places that were previously too small.



INTERNET CONTROL: Optional.



Mini ECOi LE1 Series high efficiency 8 and 10 HP · R410A

Prepare to be blown away by Panasonic's Mini VRF system.

The Mini VRF compact system is the ideal solution for minimum outdoor space.

Panasonic extends the Mini VRF range by 8 and 10 HP units.

- Piping flexibility with 150 m maximum length
- High efficiency
- Connection of up to 15 indoor units
- Quiet operation mode (one of the lowest in the market)
- High ambient temp performance
- High static pressure 35 Pa



HP			8 HP	10 HP
Outdoor unit			U-8LE1E8	U-10LE1E8
Power supply	Voltage	V	380-400-415	380-400-415
	Phase		Three phase	Three phase
	Frequency	Hz	50	50
Cooling capacity		kW	22,4	28,0
EER ¹⁾		W/W	3,80	3,11
Current		A	9,60 - 9,15 - 8,80	14,70 - 14,00 - 13,50
Input power		kW	5,89	9,00
Heating capacity		kW	25,0	28,0
COP ¹⁾		W/W	4,02	3,93
Current		A	10,20 - 9,65 - 9,30	11,60 - 11,10 - 10,70
Input power		kW	6,22	7,13
Starting current		A	1,00	1,00
Maximum current		A	13,70	19,60
Maximum input power		kW	9,16	13,10
Maximum number of connectable indoor units ²⁾			15	15
External static pressure		Pa	0 - 35	0 - 35
Air flow		m ³ /min	150	160
Sound pressure	Cool	dB(A)	60	63
	Cool (Silent 1/2/3)	dB(A)	57/55/53	60/58/56
	Heat	dB(A)	64	65
Sound power	Cool / Heat	dB(A)	81/85	84/86
Dimension	H x W x D	mm	1500 x 980 x 370	1500 x 980 x 370
Net weight		kg	132	133
Piping diameter	Liquid	Inch (mm)	3/8(9,52) ³⁾ /1/2(12,70) ⁴⁾	3/8(9,52) ³⁾ /1/2(12,70) ⁴⁾
	Gas	Inch (mm)	3/4(19,05) ³⁾ /7/8(22,22) ⁴⁾	7/8(22,22) ³⁾ /1(25,40) ⁴⁾
Maximum piping length (total)		m	7,5 - 150(7,5 - 300)	7,5 - 150(7,5 - 300)
Elevation difference (in / out)		m	50(OU above)/40(OU below)	50(OU above)/40(OU below)
Refrigerant (R410A) / CO ₂ Eq.		kg / T	6,30(24,00)/13,1544	6,60(24,00)/13,7808
Maximum allowable indoor / outdoor capacity ratio		%	50 - 130	50 - 130
Operating range	Cool Min ~ Max	°C	-10 ~ +46	-10 ~ +46
	Heat Min ~ Max	°C	-20 ~ +18	-20 ~ +18

ErP data ⁵⁾		
SEER ⁶⁾		6,27
η _{s,c}		247,9%
SCOP ⁶⁾		4,24
η _{s,h}		166,4%

1) EER and COP calculation is based in accordance to EN14511. 2) If the heating utilized, it is necessary to increase 1 size with respect to the main liquid pipe, depending on the combination of the indoor unit. 3) Under 90 m for ultimate indoor unit. 4) Over 90 m for ultimate indoor unit. If the longest piping equivalent length exceeds 90 m, increase the sizes of the main tubes by 1 rank for gas and liquid pipes. 5) SEER / SCOP and η_{s,c} / η_{s,h} are in accordance with ErP test data for F2 type variable static pressure hide-away indoor units. 6) SEER / SCOP is calculated based on the seasonal space cooling / heating efficiency "η" values of the COMMISSION REGULATION (EU) 2016/2281. SEER, SCOP = [η + Correction] × PEF.

Increase external static pressure

When unit is installed on a narrow balcony, any barrier in front will be an obstacle. High external static pressure will overcome this obstacle and maintain operating capacity.

High ambient temperature performance

Cooling operation range up to 46 °C. The system can maintain the rated (100%) capacity up to 40 °C by 8 HP model and up to 37 °C by 10 HP model.



INTERNET CONTROL: Optional.



ECOi EX. The Game Changer



VRF with outstanding energy-saving performance and powerful operation SEER 7,56 (2-Pipe 18 HP model).

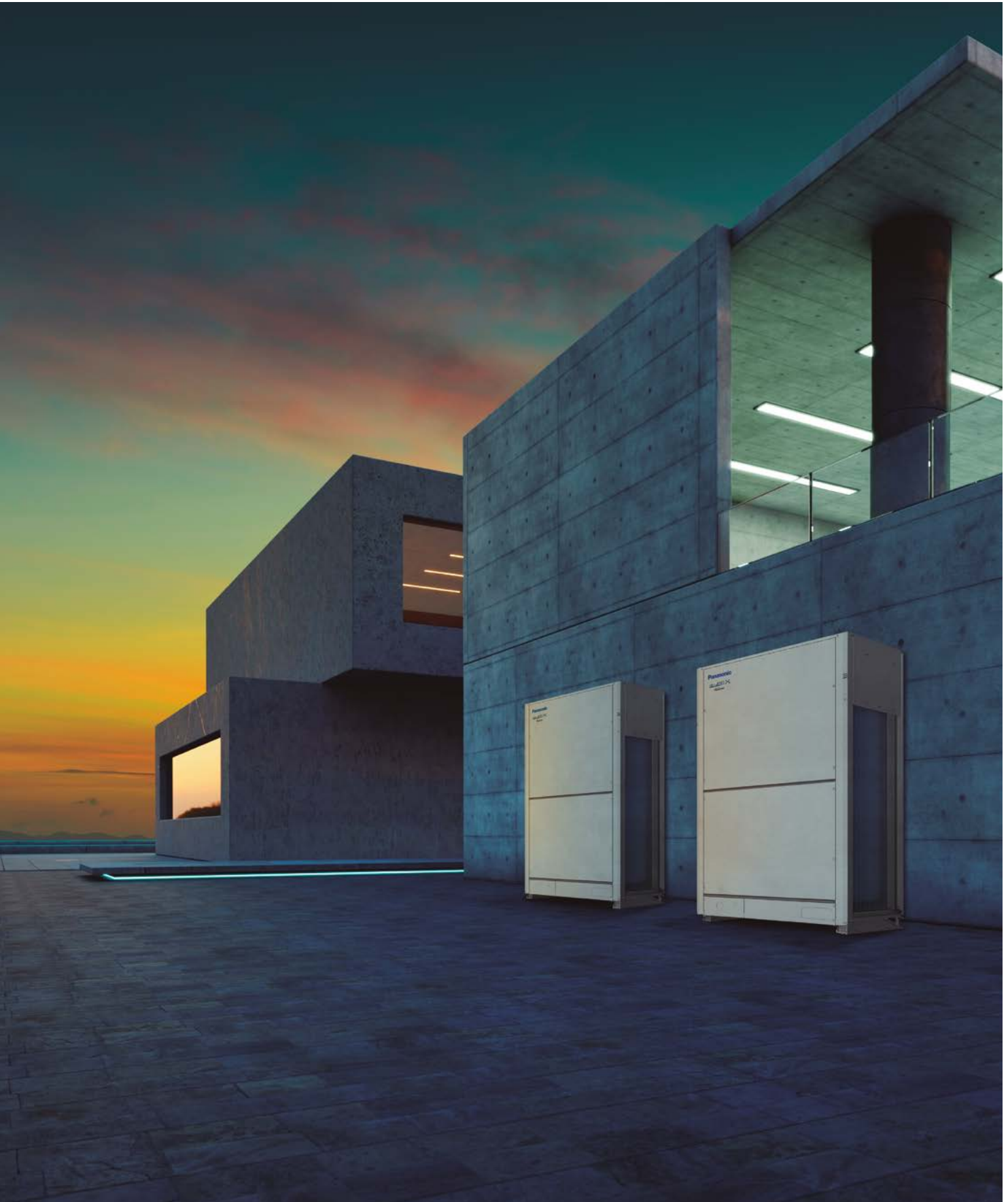

A game-changing VRF system delivering energy-saving performance, powerful operation, reliability and comfort surpassing anything previously possible.

It represents a true paradigm shift in air conditioning solutions. Taking quality to the extreme — that's the Panasonic challenge.

1 High performance at extreme conditions

ECOi EX is highly reliable, with strong cooling and heating power, even when operating at extreme ambient temperatures. The units can operate at 100% of capacity at 43 °C, reaching a great cooling operation up to 52 °C and in heating to -25 °C*.

Also, the ECOi EX features include Bluefin in the heat exchanger, improving efficiency in marine ambient. A silicone coated PCB (Printed Circuit Board) protects the unit from being damaged by environmental factors such as moisture and dust.

2 Outstanding efficiency and comfort

The ECOi EX system is designed to increase energy efficiency by delivering high SEER rating, as well as high efficiency for part-load operation.

The system has reduced energy costs thanks to "All-Inverter Compressors" with independent control, to deliver highly flexible performance. Also, the ECOi EX features an enlarged heat exchanger with triple surfaces that allow for improved heat transfer and a curved air discharge bell-mouth, for better aerodynamics. The three-stage oil recovery design makes it able to minimise the frequency of forced oil recovery, leading to reduced energy costs and sustained comfort.

3 Superior flexibility

With up to 1000* meters of pipeline, 30 meters maximum height difference between indoor units and maximum 90 meters between outdoor unit and indoor unit, the design possibilities have grown exponentially, making the ECOi EX the ideal air conditioning option for expansive buildings, such as train stations, airports, schools or hospitals. These advantages are enhanced with the wide range of indoor unit models and capacities, facilitating the perfect adaptation to all kinds of project. The careful selection of controls and peripherals such as the Pump Down, the AHU and / or the chiller, enables an optimised system selection. Maximum allowable indoor / outdoor connected capacity ratio of up to 200%.

* Conditions of 2-Pipe ECOi EX ME2 Series.



TOP efficiency and comfort

Remarkable improvement on key components: extraordinary energy-saving performance and redesigned for smooth and better air discharge.

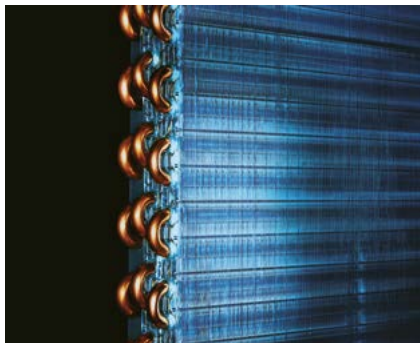

Enlarged heat exchanger surface area with triple rows.

* For 8 and 10 HP unit, the heat exchanger is 2 row design.



Multiple large-capacity all Inverter compressors (from 14 HP).



Designed curved air discharge bell mouth for better aerodynamics.

Improvements on refrigerant circuit

Compressor.

Redesigned components in the body provide performance improvements especially in the rated cooling condition and ASEER performance.



Accumulator.

Oil returning circuit with control valve makes efficient oil recovery to compressors.

Oil separator.

Modified tank design makes efficient oil separation with less pressure drop.

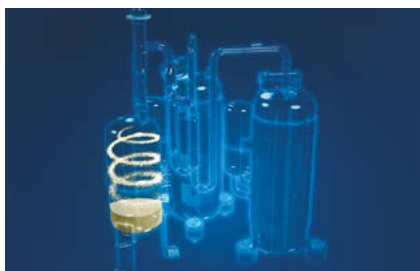

Receiver tank-less design

Improved refrigerant control program recovers the remaining refrigerant gas in the system back to the accumulator tank effectively.



Smooth exhaust flow by bell-mouth

The curved shape with integrated top and bottom assure smooth exhaust flow. This gives more air-volume with same sound level, less input power at same air flow.

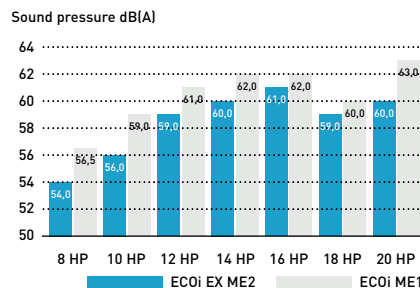
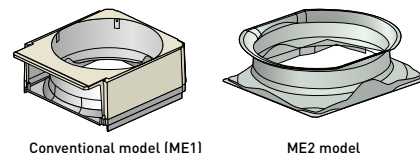

Combined 3 surface heat exchanger

The highly efficient piping pattern increases heat exchange performance by 5%. The heat exchanger features a 3 surface construction. Compared to the divided dual-surface construction in current models, there is no divided space and the face area of heat exchanger becomes larger.

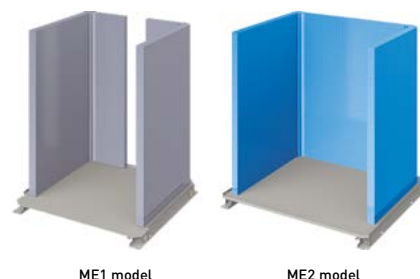

Oil recovery intelligent control

Oil recovery intelligent control advantages:

1. Higher efficiency
2. Durability
3. Comfort: continuous operation, low noise and low vibration

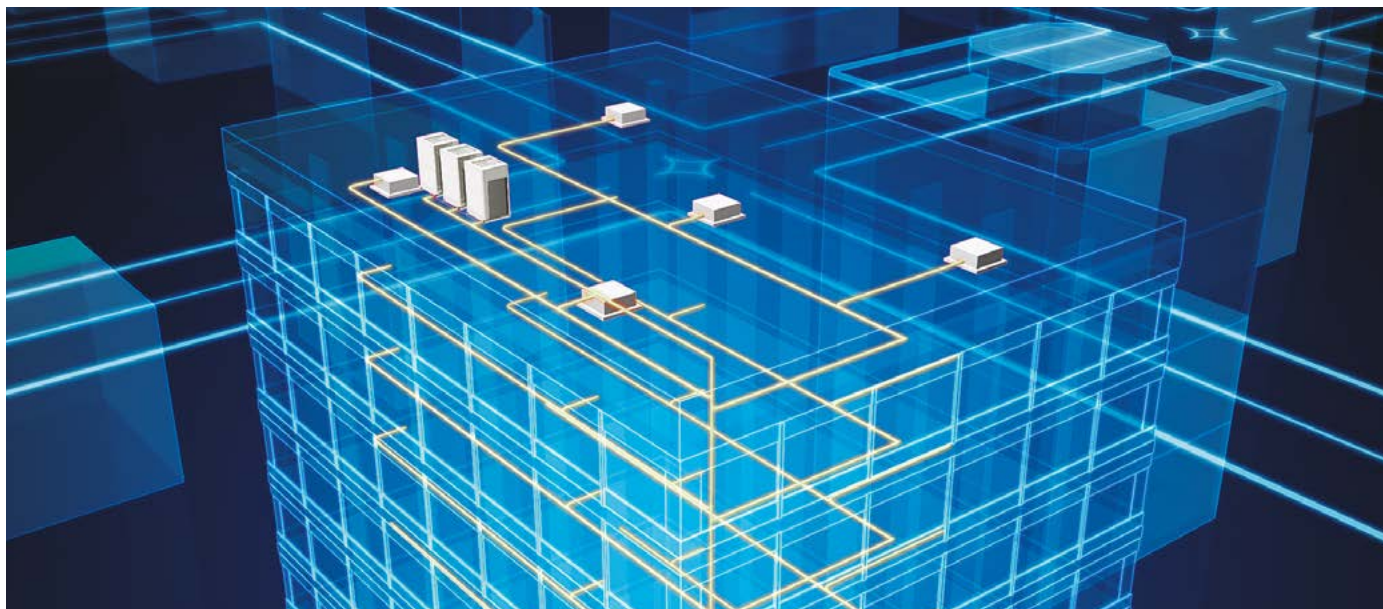

Intelligent 3-stage oil management system

In a VRF system, where lengthy piping and a large number of indoor units need to be controlled collectively, the key to maintaining the system's reliability is to ensure an appropriate amount of oil is secured in the compressors. In order to avoid oil shortage in the compressor, maximum operation is normally forcibly conducted at regular intervals to recover oil from indoor units. This method, typically employed in a standard VRF, causes the system to overheat or overcool and thus waste energy. In Panasonic VRF systems, a sensor for detecting oil levels is mounted in each compressor. In installations with multiple outdoor units, a shortage of oil in one compressor can be compensated for by recovering oil either from another compressor in the same unit, from a compressor in an adjacent outdoor unit, or from connected indoor units. Panasonic VRF systems provide users with a comfortable environment whilst saving energy.

The Panasonic system efficiently manages oil recovery in three stages; minimising the frequency of forced oil recovery while reducing energy cost and maintaining comfort.

STAGE-1: Panasonic compressors are equipped with sensors which monitor oil levels precisely at all times. If oil levels fall, oil can be transferred from other compressors within the same outdoor unit.

STAGE-2: If oil levels in all compressors within the outdoor unit fall, oil can be replenished from adjacent outdoor units.

STAGE-3: Forced oil recovery is implemented only if oil levels become insufficient in spite of above measures. The Panasonic system's design concept is radically different from conventional oil systems.

Features of oil recovery design

Oil sensors installed in each compressor.

Oil sensors installed in each Panasonic compressor precisely monitor oil levels, eliminating unnecessary oil recovery.

Highly functional oil separator.

Thanks to extended separate piping, oil recovery efficiency reaches 90%, minimising the oil discharged from the compressor.

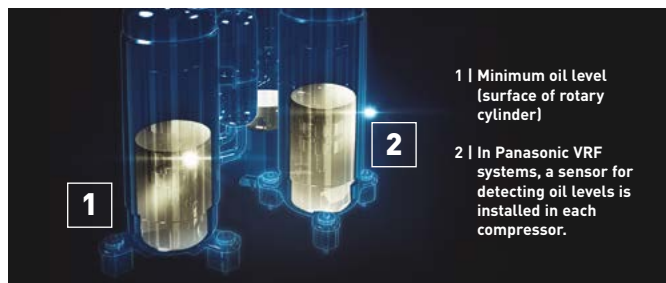

Twin rotary Inverter compressor

- Wider and flexible control on Inverter compressor
- Better oil lubrication
- Smooth start up

Extraordinary energy-saving performance

Designed for Actual Operation Performance. Panasonic builds air conditioning systems not only with a high EER for rated operation, but also with Seasonal-EER appropriate to the customer's actual environment of use. For instance, with rated operation, outdoor temperature is constant at 35 °C, but in reality the outdoor temperature is continuously changing. Consequently, required air conditioning performance also changes. That's why Panasonic implements the following kind of proprietary control.

Compressor efficiency electric system VRF. COP

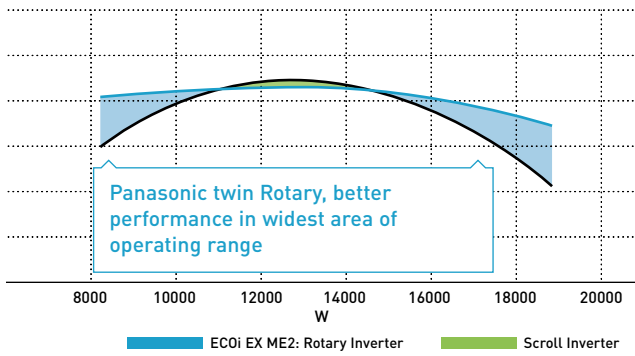

- 1 | Set temperature is rapidly attained; full-load operating time is kept to a minimum.
- 2 | The frequency of forced oil recovery is minimised. The volume of oil within the compressors is monitored precisely by sensors, so forced oil recovery under full-load operation is conducted only when necessary. Since this suppresses noise due to oil recovery, comfort is maintained.
- 3 | Panasonic pursues a high EER, of course, as well as high EER in part load, for energy saving performance under a broad range of loads.

Panasonic's design concept contributes to substantial energy cost reductions.

Number of Inverter compressors.

Size	2-Pipe ECOi EX ME2						3-Pipe ECOi EX MF3					
	Small		Medium			Large	Medium					
HP	8	10	12	14	16	18	20	8	10	12	14	16
Number	1 pc.		1 pc.	2 pcs.	2 pcs.	2 pcs.		1 pc.			2 pcs.	

Actual operation data graph of Panasonic VRF

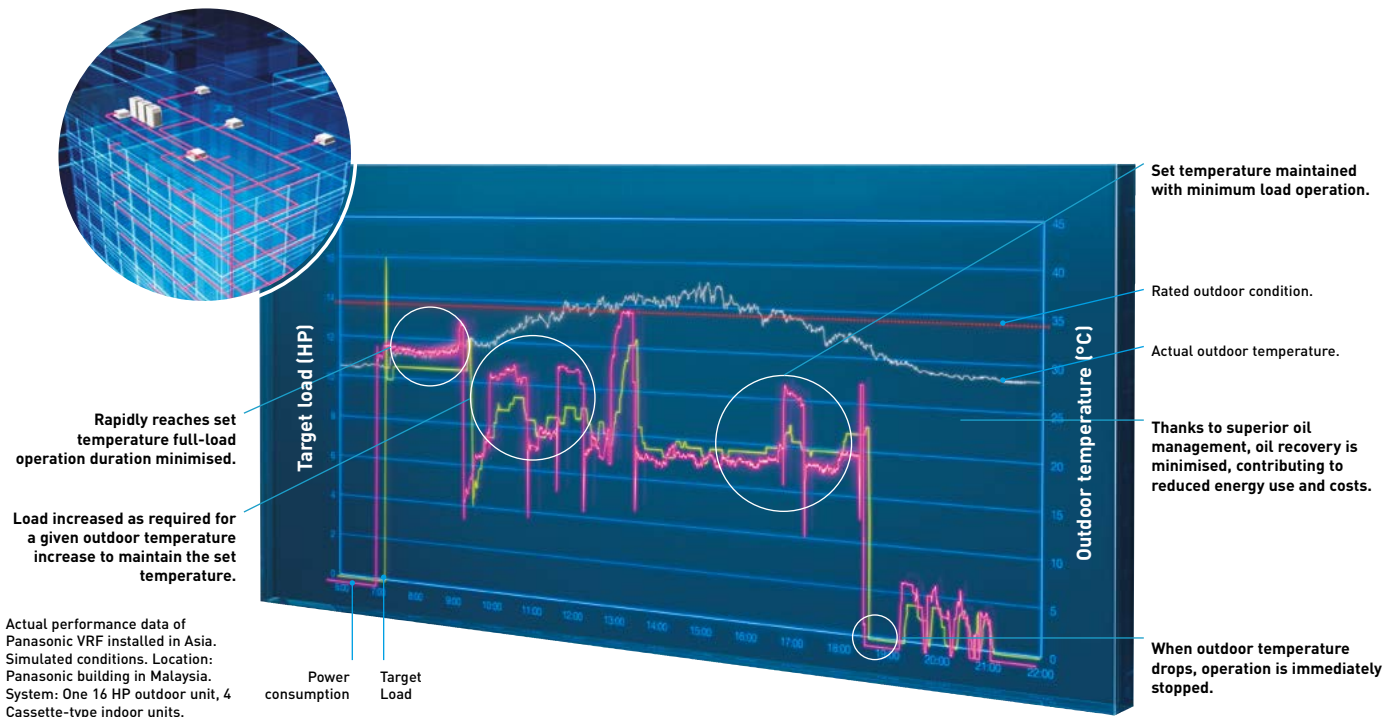

Superior quality, reliability and durability

Two independently controlled Inverter compressors achieve high efficiency. Redesigned components in the body provide performance improvement especially in the rated cooling condition and EER performance.

High safety operation in case of breakdown!

Automatic Back-Up operation. Ensures heating and cooling.

It is possible for the system to keep working, even if the compressors, fan motor and the temperature sensor are damaged (even when a compressor fails in single unit with 2 compressors inside).

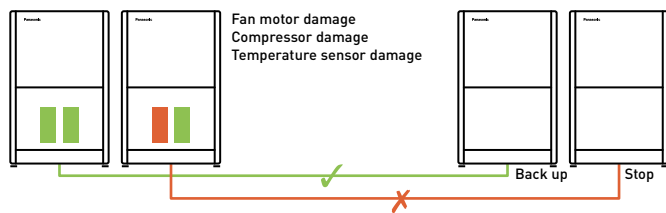

The system will still operate with only 25% of the connected indoor units.

System will not stop when only 25% of indoor units have power supply and breakdown on other indoor units.

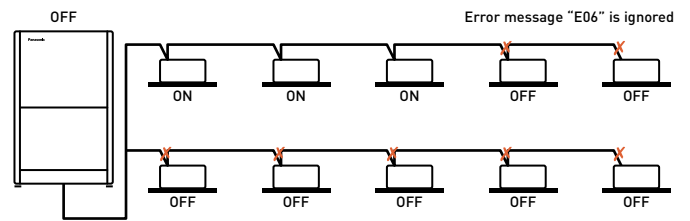

Hi-durability outdoor unit

Treated for high resistance to corrosion (rust and salty air) to ensure long-lasting performance.

Note: Selecting this unit does not completely eliminate the possibility of rust developing. For details concerning unit installation and maintenance, please consult an authorised dealer.

Specially protected parts.

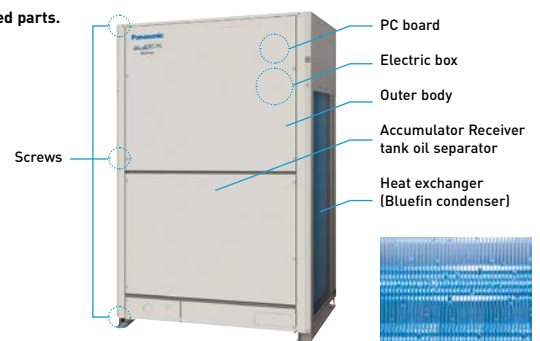

Extended compressor life by uniform compressor operation time

The total run-time of compressors are monitored by a built-in microcomputer, which ensures that operation times of all compressors within the same refrigerant circuit are balanced.

Compressors with histories showing shorter run times are selected first, ensuring equal wear and tear across all units and extending the working life of the system.

System example.

A,C: DC Inverter compressor

B,D: Constant speed compressor

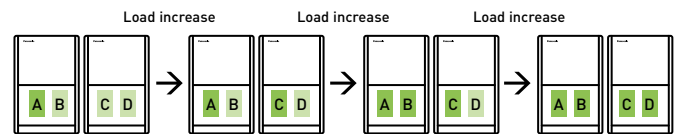

50 h 30 h 60 h 10 h

* Depend on accumulated operation time of each compressors.

* Compressor priority has possibility to be changed.

[e.g] Case 1: A>C>B>D, Case 2: C>A>D>B, Case 3: A>C>D>B, Case 4: C>A>B>D

* Also other cases available.

A large number of indoor unit models can be connected.



2-Pipe ECOi EX ME2 Series



Extraordinary partial load, SEER and SCOP.

Efficiency in VRF systems

In the past it was only possible to compare the nominal efficiency at outdoor ambient temperature of 35 °C (EER) in Cooling and at 7 °C in heating (COP). With EN-14825 seasonal efficiency will be shown, the result will be SEER and SCOP. ECOi EX is reaching excellent performance without using any additional saving functions.

The highest EER / COP rating in most capacities

Compared to conventional model ECOi (ME1)

The ECOi EX marks a revolutionary step forward in VRF efficiency. A look at the incredible EER / COP value clearly indicates that. What's more, this high EER / COP value is achieved even during part load operation. This shows the extraordinary energy-saving performance the ECOi EX is capable of providing.

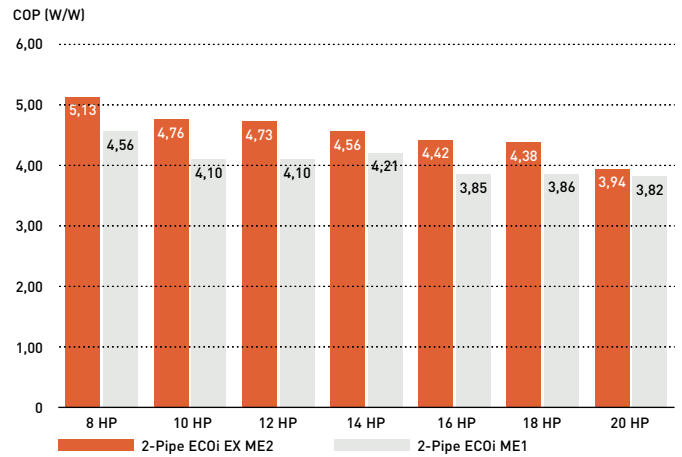
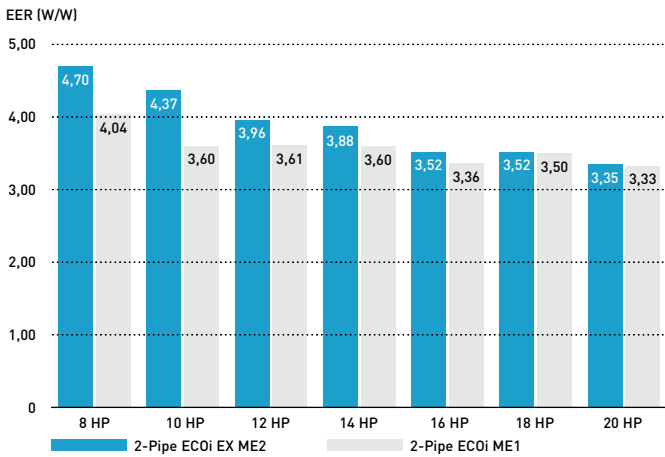

Partial load for seasonal and real system efficiency

VRF units are designed to adapt to the heating and cooling demand, adapting its performance to different outdoor conditions. When compressor runs at lower than 100% capacity, the system is working at partial load. A wider compressor operating range results in better system performance both at full load and partial load conditions. Panasonic ECOi EX partial load is excellent, reaching a minimum of 15% of compressor capacity.

Excellent efficiency at any condition and partial load

In both heating and cooling mode, Panasonic ECOi EX is reaching exceptional levels of efficiency.

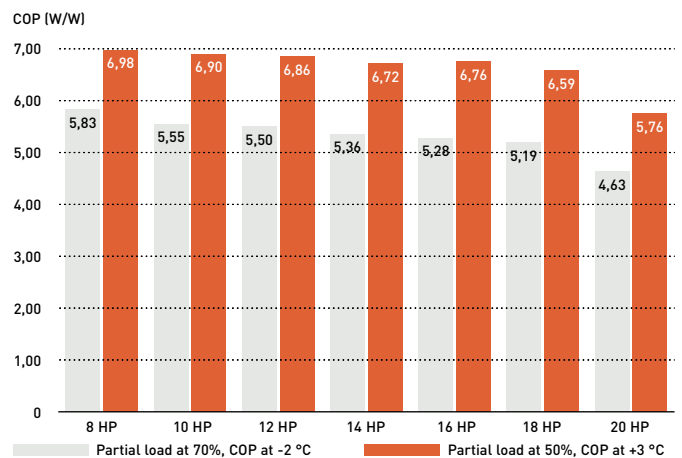
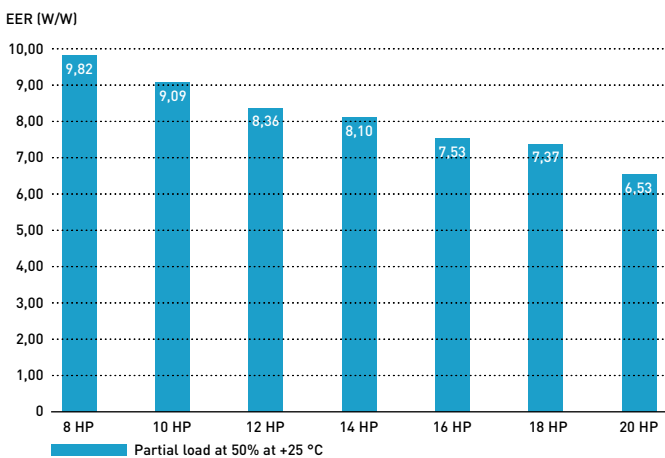

SEER and SCOP following EN-14825

When better partial load, better efficiency is achieved in real operation. The EN-14825 is showing the way to calculate considering full year operation hours at different conditions. Panasonic ECOi EX is designed to save energy in any partial load condition. During most operation hours a system is under partial load conditions, 80% of total operation hours is less than 70% of full load.

In below graphs is the example for average ambient conditions, this uses Strasbourg ambient conditions for calculation.

Outside temperature distribution.

Time distribution (hours / year)

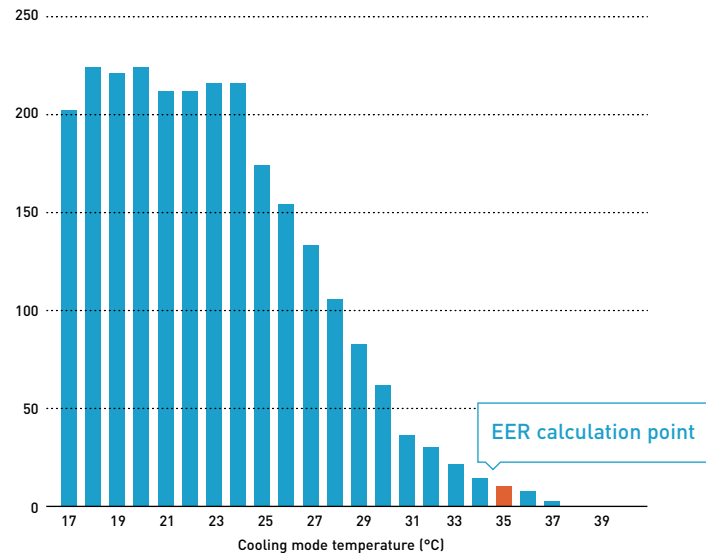

Outside temperature distribution.

Time distribution (hours / year)

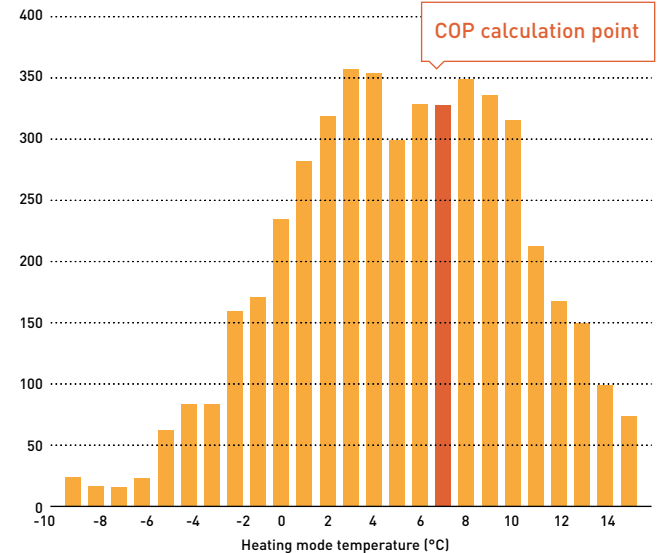

In the characteristics EER and COP only a single temperature for the assessment of the efficiency is taken as a basis in each case. Data calculated under EN-14825 conditions, not additional saving function considered for this calculation. Compressor frequency according to ambient temperature and building design.

SEER and SCOP values

ECOi EX models have superior seasonal space cooling / heating efficiency following not only EN 14825 but also COMMISSION REGULATION (EU) 2016/2281. This regulation requires to use "η" values in the technical documents.

Please visit our websites www.aircon.panasonic.eu or www.ptc.panasonic.eu.

During commissioning, Panasonic can further increase efficiency by "20%" increasing evaporation refrigerant temperature range, for a higher efficiency and lower energy consumption.

SEER / SCOP

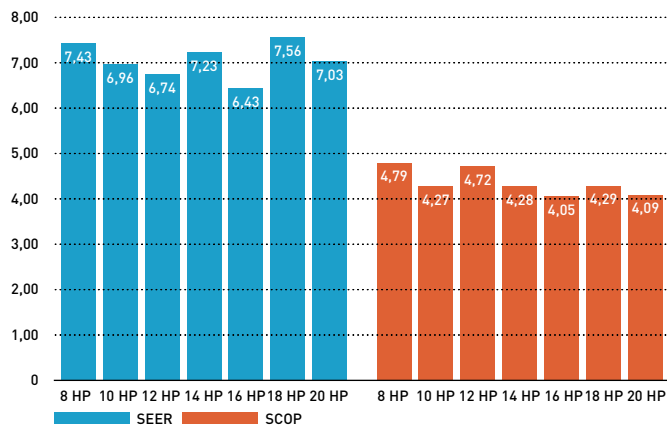

ESEER (W/W)

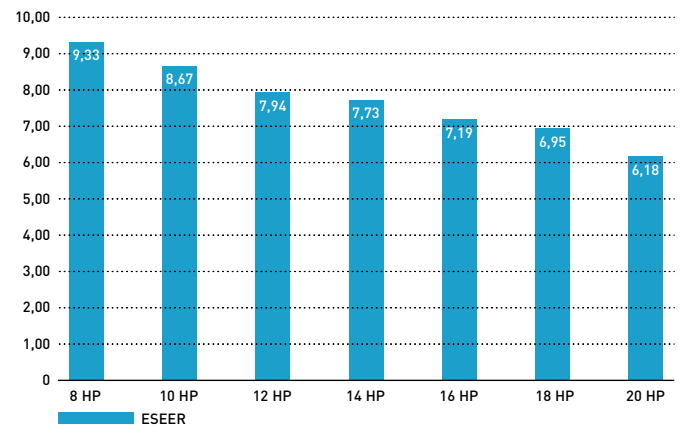

2-Pipe ECOi EX ME2 Series high performance at extreme conditions

The ECOi EX can still operate at 100% capacity when the outside temperature is as high as 43 °C. This high power capability enables reliable operation even under extremely high temperature conditions.

Extremely high capacity at -20 °C and unique heating capacity at -25 °C

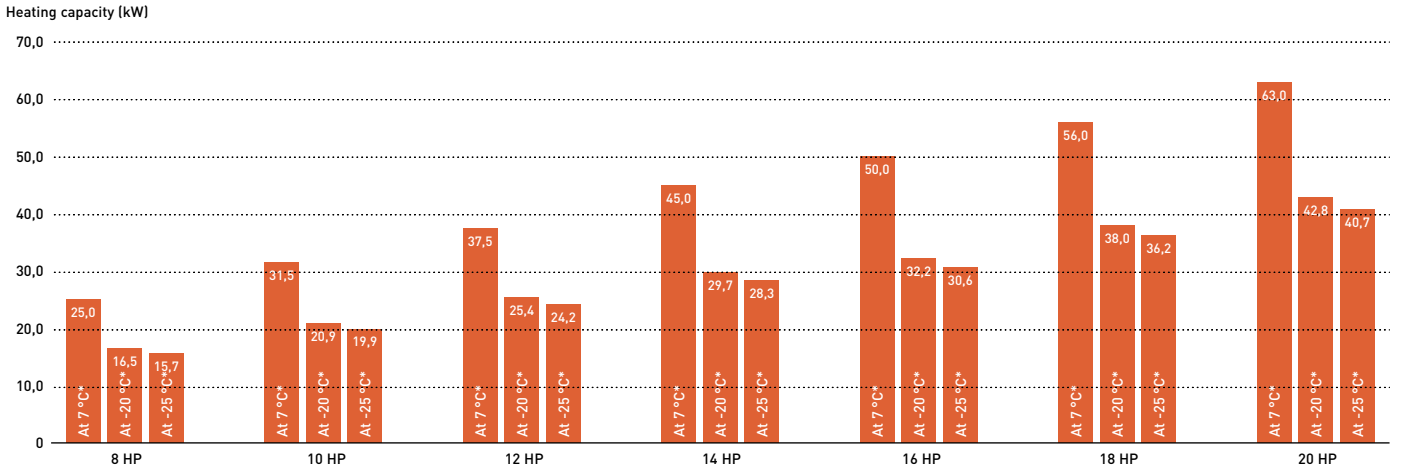

* Outdoor air temperature [°C WB].

Trusted reliability even under high and low temperature conditions

Designed to be durable enough to withstand extreme heat, 2-Pipe ECOi EX ME2 Series ensures reliable cooling operation over an extended operating range up to 52 °C, and heating operation also at -25 °C.

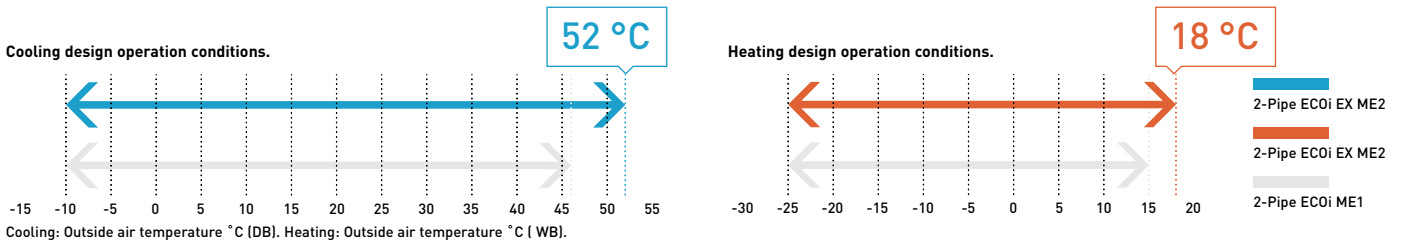

2-Pipe ECOi EX ME2 Series superior flexibility

Maximum allowable connected indoor / outdoor capacity ratio up to 200%*

ECOi EX attain maximum indoor unit connection capacity of up to 130% of the unit's connection range. This limit can be surpassed and reach up to 200% if some conditions are satisfied. With this feature, ECOi EX provides an ideal air conditioning solution for locations where full cooling / heating are not always required in all spaces at same time.

System (HP)	8	10	12	14	16	18	20	22	24	26	28	30	32	34	36	38	40	42	44	46	48	50	52	54	56	58	60	62	64	66	68	70	72	74	76	78	80						
Connectable indoor units: 130%	13	16	19	23	26	29	33	36	40	43	46	50	53	56	59															64													
Connectable indoor units: 200%	20	25	30	35	40	45	50	55	60											64																							

Note: If more than 100% indoor units are operated with a high load, the units may not perform at the rated capacity. For the details, please consult with an authorised Panasonic dealer. * If the following conditions are satisfied, the effective range is above 130% up to 200%. Obey the limited number of connectable indoor units. The lower limit of operating range for heating outdoor temperature is limited to -10 °C WB (standard -25 °C WB). Simultaneous operation is limited to less than 130% of connectable indoor units. 1.5 kW capacity of Indoor Units are included.

Increased piping lengths and design flexibility

Adaptable to various building types and sizes. Actual piping length: 200 m. Maximum piping length: 1000 m.

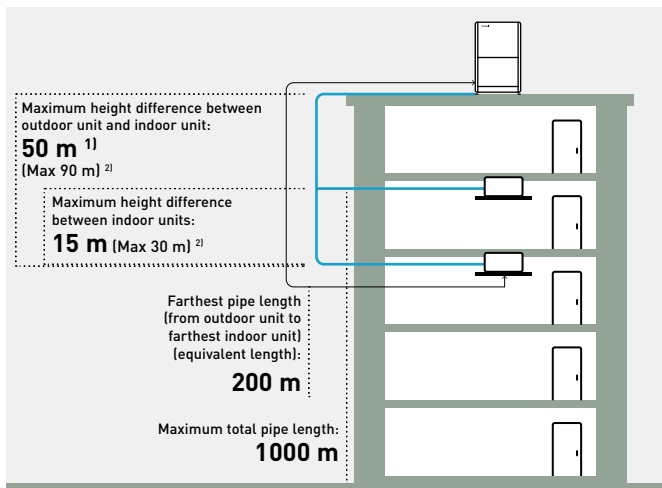

1) 40 m if the outdoor unit is below the indoor unit.
2) For height differences between outdoor unit and indoor unit > 50 m, as well as for height differences between indoor units > 15 m, contact an authorized Panasonic dealer.

Up to 50 m length difference between the longest and the shortest piping from the first branch

Flexible piping layout makes it easier to design systems for locations such as train stations, airports, schools and hospitals.

- Up to 64 units can be connected to one system
- Difference between maximum and minimum pipe runs after first branch can be a maximum of 50 m
- Larger pipe runs can be up to 200 m

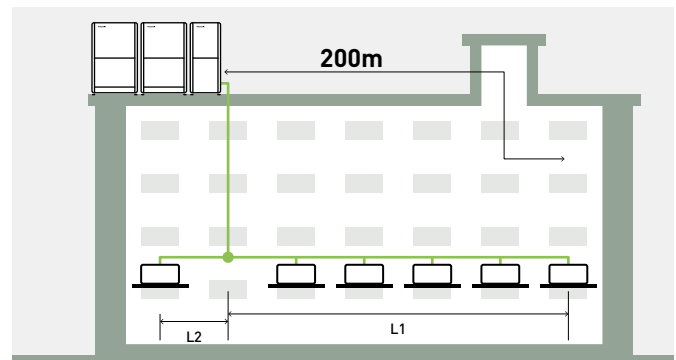

Compact design

The ME2 Series has reduced the installation space required with up to 20 HP available in a single chassis. 8 - 10 HP are able to fit inside a lift for easy handling on site.

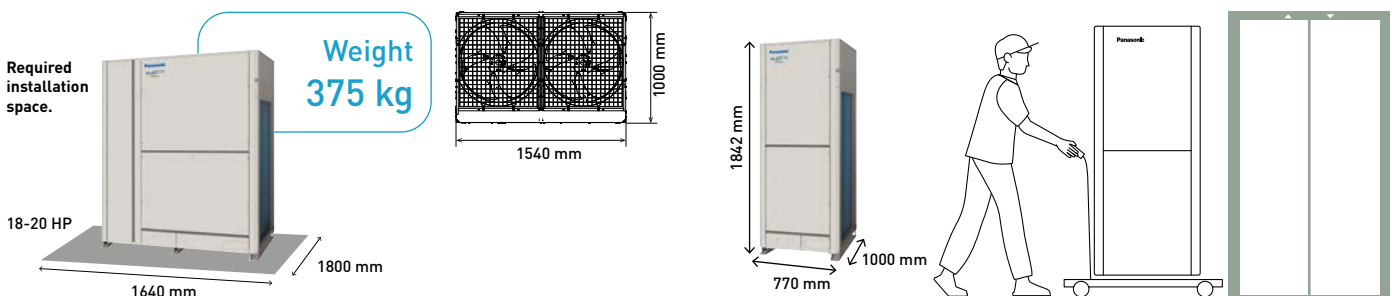

2-Pipe ECOi EX ME2 Series piping design

Select installation locations so that the lengths and sizes of refrigerant piping are within the allowable ranges shown in the figure below.

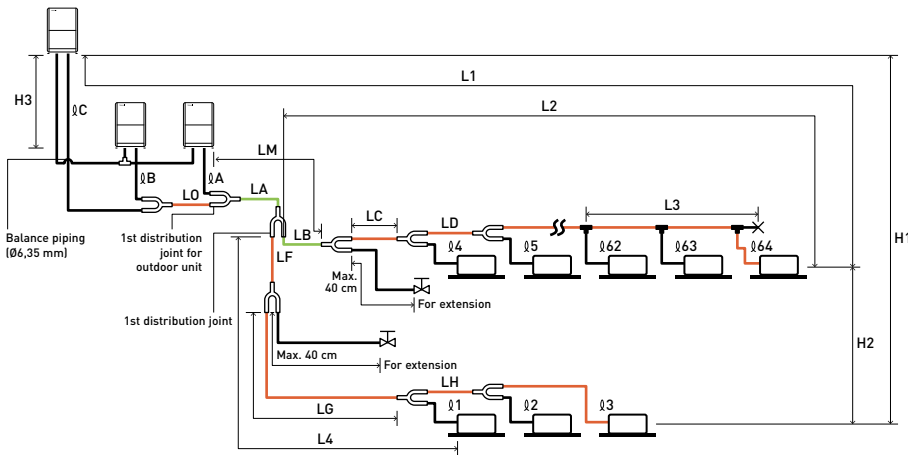

The outdoor connection main piping (LO portion) is determined by the total capacity of the outdoor units that are connected to the tube ends.

Note: Be sure to use special R410A distribution joints (CZ: optional parts) for outdoor unit connections and piping branches.

R410A distribution joint.

- CZ-P680PH2BM (for outdoor unit)
- CZ-P1350PH2BM (for outdoor unit)
- CZ-P224BK2BM (for indoor unit)
- CZ-P680BK2BM (for indoor unit)
- CZ-P1350BK2BM (for indoor unit)

Main piping length (maximum piping size) LM= LA + LB ...

Main distribution tubes LC – LH are selected according to the capacity after the distribution joint.

Sizes of indoor unit connection piping φ1 – φ64 are determined by the connection piping sizes on the indoor units.

Distribution joint (CZ: optional parts).

Ball valve (field supply).

T-joint (field supply).

Solidly welded shut (pinch weld).

Ranges that apply to refrigerant piping lengths and to differences in installation heights

Items	Mark	Contents	Length (m)
Allowable piping length	L1	Maximum piping length	Actual length ≤200 ¹⁾ Equivalent length ≤210 ¹⁾
	Δ L (L2-L4)	Difference between maximum length and minimum length from the 1st distribution joint	≤50 ²⁾
	LM	Maximum length of main piping (at maximum size) * Even after 1st distribution joint, LM is allowed if at maximum piping length.	— ³⁾
	φ1, φ2- φ64	Maximum length of each distribution tube	≤50 ⁴⁾
	L1+ φ1+ φ2- φ63+ φA+φB+LF+LG+LH	Total maximum piping length including length of each distribution tube (only liquid piping)	≤1000
Allowable elevation difference	φA, φB+LO, φC+LO	Maximum piping length from outdoor's 1st distribution joint to each outdoor unit	≤10
	H1	When outdoor unit is installed higher than indoor unit	≤50
	H2	When outdoor unit is installed lower than indoor unit	≤40
	H3	Maximum difference between indoor units	≤15
Allowable length of joint piping	H3	Maximum difference between outdoor units	≤4
	L3	T-joint piping (field-supply); Maximum piping length between the first T-joint and solidly welded-shut end point	≤2

L = Length, H = Height

1) If the longest piping length (L1) exceeds 90 m (equivalent length), increase the sizes of the main tubes (LM) by 1 rank for gas tubes and liquid tubes. Use a field supply reducer. Select the tube size from the table of main piping sizes (Table 3) and from the table of refrigerant piping sizes (Table 8). 2) When the piping length exceeds 40 m, increase a longer liquid or gas piping by 1 rank. Refer to the Technical Data for the details. 3) If the longest main piping length (LM) exceeds 50 m, increase the main piping size at the portion before 50 m by 1 rank for the gas tubes. Use a field supply reducer. Determine the length less than the limitation of allowable maximum piping length. For the portion that exceeds 50 m, set based on the main piping size (LA) listed in Table 3. 4) If any of the piping length exceeds 30 m, increase the size of the liquid and gas tubes by 1 rank. 5) If the total distribution piping length exceeds 500 m, maximum allowable elevation difference (H2) between the indoor units is calculated by the following formula. Make sure the indoor unit's actual elevation difference should fall within the figure calculated as follows. Unit of account (meter): $15 \times (2 - \text{total piping length (m)} \div 500)$.

* The outdoor connection main piping (LO portion) is determined by the total capacity of the outdoor units that are connected to the tube ends. If the size of the existing piping is already larger than the standard piping size, it is not necessary to further increase the size. ** If the existing piping is used, and the amount of on-site refrigerant charge exceeds the value listed below, then change the size of the piping to reduce the amount of refrigerant. Total amount of refrigerant for the system with 1 outdoor unit: 50kg. Total amount of refrigerant for the system with 2 outdoor units: 80kg. Total amount of refrigerant for the system with 3 outdoor units or 4 outdoor units: 105 kg.

Necessary amount of additional refrigerant charge per outdoor unit.

U-8ME2E8	U-10ME2E8	U-12ME2E8	U-14ME2E8	U-16ME2E8
5,5 kg	5,5 kg	7,0 kg	7,0 kg	7,0 kg

System limitations.

Maximum number allowable connected outdoor units	4 ¹⁾
Maximum capacity allowable connected outdoor units	224 kW (80 HP)
Maximum connectable indoor units	64 ²⁾
Maximum allowable indoor / outdoor capacity ratio	50-130% ³⁾

- 1) Up to 4 units can be connected if the system has been extended.
- 2) In the case of 38 HP or smaller units, the number is limited by the total capacity of the connected indoor units.
- 3) If the following conditions are satisfied, the effective range is above 130% and below 200%.
 - A) Obey the limited number of connectable indoor units. B) The lower limit of operating range for heating outdoor temperature is limited to -10 °C WB (standard -25 °C WB). C) Simultaneous operation is limited to less than 130% of connectable indoor units.

Additional refrigerant charge.

Liquid piping size (Inch (mm))	1/4	3/8	1/2	5/8	3/4	7/8	1
	(6,35)	(9,52)	(12,70)	(15,88)	(19,05)	(22,22)	(25,40)
Amount of refrigerant charge (g/m)	26	56	128	185	259	366	490

Refrigerant piping (existing piping can be used).

Piping size (mm)				Material Temper - 1/2 H, H									
Material Temper - 0													
φ6,35	t 0,8	φ12,70	t 0,8	φ19,05	t 1,2	φ22,22	t 1,0	φ28,58	t 1,0	φ38,10	over t 1,35	φ44,45	over t1,55
φ9,52	t 0,8	φ15,88	t 1,0			φ25,40	t 1,0	φ31,75	t 1,1	φ41,28	over t 1,45	φ44,45	over t1,55

* When bending the tubes, use a bending radius that is at least 4 times the outer diameter of the tubes. In addition, take sufficient care to avoid crushing or damaging the tubes when bending them.

2-Pipe ECOi EX ME2 Series

A VRF system delivering energy-saving performance, powerful operation, reliability and comfort, surpassing anything previously possible. It represents a true paradigm shift in air conditioning solutions.

VRF with outstanding energy-saving performance and powerful operation SEER 7,56 (18 HP model).



HP			8 HP	10 HP	12 HP	14 HP	16 HP	18 HP	20 HP
Outdoor unit			U-8ME2E8	U-10ME2E8	U-12ME2E8	U-14ME2E8	U-16ME2E8	U-18ME2E8	U-20ME2E8
	Power supply	Voltage	380-400-415	380-400-415	380-400-415	380-400-415	380-400-415	380-400-415	380-400-415
		Phase	Three phase	Three phase	Three phase	Three phase	Three phase	Three phase	Three phase
		Frequency	50	50	50	50	50	50	50
	Cooling capacity	kW	22,4	28,0	33,5	40,0	45,0	50,0	56,0
	EER ¹⁾	W/W	4,70	4,37	3,96	3,88	3,52	3,52	3,35
	ESEER	W/W	9,33	8,67	7,94	7,73	7,19	6,95	6,18
	Current	A	7,79-7,40-7,14	10,70-10,20-9,80	13,70-13,00-12,50	17,40-16,50-15,90	21,10-20,10-19,40	23,20-22,00-21,20	26,70-25,40-24,50
	Input power	kW	4,77	6,41	8,47	10,30	12,80	14,20	16,70
	Heating capacity	kW	25,0	31,5	37,5	45,0	50,0	56,0	63,0
	COP ¹⁾	W/W	5,13	4,76	4,73	4,56	4,42	4,38	3,94
	Current	A	7,96-7,56-7,29	11,10-10,50-10,10	12,90-12,30-11,80	16,60-15,80-15,20	18,90-17,90-17,30	21,10-20,10-19,40	25,90-24,60-23,70
	Input power	kW	4,87	6,62	7,92	9,86	11,30	12,80	16,00
	Starting current	A	1,00	1,00	1,00	2,00	2,00	2,00	2,00
	External static pressure (Max)	Pa	80	80	80	80	80	80	80
	Air flow	m ³ /min	224	224	232	232	232	405	405
Sound pressure	Normal mode	dB(A)	54	56	59	60	61	59	60
	Silent mode	dB(A)	51	53	56	57	58	56	57
Sound power	Normal mode	dB(A)	75	77	80	81	82	80	81
Dimension	H x W x D	mm	1842 x 770 x 1000	1842 x 770 x 1000	1842 x 1180 x 1000	1842 x 1180 x 1000	1842 x 1180 x 1000	1842 x 1540 x 1000	1842 x 1540 x 1000
Net weight		kg	210	210	270	315	315	375	375
Piping diameter ²⁾	Liquid	Inch (mm)	3/8(9,52)/1/2(12,70)	3/8(9,52)/1/2(12,70)	1/2(12,70)/5/8(15,88)	1/2(12,70)/5/8(15,88)	1/2(12,70)/5/8(15,88)	5/8(15,88)/3/4(19,05)	5/8(15,88)/3/4(19,05)
	Gas	Inch (mm)	3/4(19,05)/7/8(22,22)	7/8(22,22)/1(25,40)	1(25,40)/1-1/8(28,58)	1(25,40)/1-1/8(28,58)	1-1/8(28,58)/1-1/4(31,75)	1-1/8(28,58)/1-1/4(31,75)	1-1/8(28,58)/1-1/4(31,75)
	Balance	Inch (mm)	1/4(6,35)	1/4(6,35)	1/4(6,35)	1/4(6,35)	1/4(6,35)	1/4(6,35)	1/4(6,35)
Refrigerant (R410A) / CO ₂ Eq	kg/T		5,60/11,6928	5,60/11,6928	8,30/17,3304	8,30/17,3304	8,30/17,3304	9,50/19,836	9,50/19,836
Maximum allowable indoor / outdoor capacity ratio ³⁾	%		50-130(200)	50-130(200)	50-130(200)	50-130(200)	50-130(200)	50-130(200)	50-130(200)
Operating range	Cool Min ~ Max	°C	-10 ~ +52	-10 ~ +52	-10 ~ +52	-10 ~ +52	-10 ~ +52	-10 ~ +52	-10 ~ +52
	Heat Min ~ Max	°C	-25 ~ +18	-25 ~ +18	-25 ~ +18	-25 ~ +18	-25 ~ +18	-25 ~ +18	-25 ~ +18

ErP data ⁴⁾								
SEER ⁵⁾		7,43	6,96	6,74	7,23	6,43	7,56	7,03
$\eta_{s,c}$		294,3%	275,4%	266,6%	286,0%	254,3%	299,2%	278,2%
SCOP ⁵⁾		4,79	4,27	4,72	4,28	4,05	4,29	4,09
$\eta_{s,h}$		188,4%	167,6%	185,8%	168,2%	159,0%	168,7%	160,4%

1) EER and COP calculation is based in accordance to EN14511. 2) Piping diameter under 90 m for ultimate indoor unit / over 90 m for ultimate indoor unit (if the longest piping equivalent length exceeds 90 m, increase the sizes of the main tubes by 1 rank for gas tubes and liquid tubes). 3) If the following conditions are satisfied, the effective range is above 130% and below 200%: A. Obey the limited number of connectable indoor units. B. The lower limit of operating range for heating outdoor temperature is limited to -10 °C WB (standard -25 °C WB). C. Simultaneous operation is limited to less than 130% of connectable indoor units. 4) SEER / SCOP and $\eta_{s,c}$ / $\eta_{s,h}$ are in accordance with ErP test data for F2 type variable static pressure hide-away indoor units. 5) SEER / SCOP is calculated based on the seasonal space cooling / heating efficiency " η " values of the COMMISSION REGULATION (EU) 2016/2281. SEER, SCOP = (η + Correction) x PEF.

Technical focus

- Twin rotary Inverter compressor
- High performance at extreme conditions
- Outstanding efficiency and comfort
- Extraordinary partial load, SEER and SCOP
- SEER and SCOP following EN-14825
- Oil recovery intelligent control
- Top comfort
- Superior flexibility
- Bluefin full line up EX
- Extremely high capacity at -20 °C and unique heating capacity at -25 °C
- Smooth exhaust flow by bell-mouth



2-Pipe ECOi EX ME2 Series high efficiency model combination from 18 to 64 HP

HP			18 HP	20 HP	22 HP	24 HP	26 HP	28 HP
Outdoor unit			U-8ME2E8	U-10ME2E8	U-10ME2E8	U-12ME2E8	U-10ME2E8	U-12ME2E8
			U-10ME2E8	U-10ME2E8	U-12ME2E8	U-12ME2E8	U-16ME2E8	U-16ME2E8
Power supply	Voltage	V	380-400-415	380-400-415	380-400-415	380-400-415	380-400-415	380-400-415
	Phase		Three phase	Three phase	Three phase	Three phase	Three phase	Three phase
	Frequency	Hz	50	50	50	50	50	50
Cooling capacity	kW		50,0	56,0	61,5	68,0	73,0	78,5
EER ¹⁾	W/W		4,55	4,38	4,13	3,93	3,80	3,69
Current	A		18,20-17,30-16,60	21,40-20,30-19,60	24,30-23,10-22,30	28,00-26,60-25,60	31,70-30,10-29,00	34,80-33,10-31,90
Input power	kW		11,00	12,80	14,90	17,30	19,20	21,30
Heating capacity	kW		56,0	63,0	69,0	76,5	81,5	87,5
COP ¹⁾	W/W		4,96	4,77	4,76	4,69	4,55	4,56
Current	A		18,70-17,70-17,10	22,00-20,90-20,20	23,90-22,70-21,90	26,60-25,30-24,40	29,90-28,40-27,40	31,70-30,10-29,00
Input power	kW		11,30	13,20	14,50	16,30	17,90	19,20
Starting current	A		2,00	2,00	2,00	2,00	3,00	3,00
External static pressure (Max)	Pa		80	80	80	80	80	80
Air flow	m ³ /min		448	448	456	464	456	464
Sound pressure	Normal	dB(A)	58,5	59,0	61,0	62,0	62,5	63,5
	Silent mode	dB(A)	55,5	56,0	58,0	59,0	59,5	60,5
Sound power	Normal mode	dB(A)	79,5	80,0	82,0	83,0	83,5	84,5
Dimension / Net weight	HxWxD	mm / kg	1842x1600 x1000/420	1842x1600 x1000/420	1842x2010 x1000/480	1842x2420 x1000/540	1842x2010 x1000/535	1842x2420 x1000/585
Piping diameter ²⁾	Liquid	Inch (mm)	5/8(15,88)/ 3/4(19,05)	5/8(15,88)/ 3/4(19,05)	5/8(15,88)/ 3/4(19,05)	5/8(15,88)/ 3/4(19,05)	3/4(19,05)/ 7/8(22,22)	3/4(19,05)/ 7/8(22,22)
	Gas	Inch (mm)	1-1/8(28,58)/ 1-1/4(31,75)	1-1/8(28,58)/ 1-1/4(31,75)	1-1/8(28,58)/ 1-1/4(31,75)	1-1/8(28,58)/ 1-1/4(31,75)	1-1/4(31,75)/ 1-1/2(38,10)	1-1/4(31,75)/ 1-1/2(38,10)
	Balance	Inch (mm)	1/4(6,35)	1/4(6,35)	1/4(6,35)	1/4(6,35)	1/4(6,35)	1/4(6,35)
Refrigerant (R410A) / CO ₂ Eq.	kg / T		11,20/23,3856	11,20/23,3856	13,90/29,0232	16,60/34,6608	13,90/29,0232	16,60/34,6608
Maximum allowable indoor / outdoor capacity ratio ³⁾	%		50-130(200)	50-130(200)	50-130(200)	50-130(200)	50-130(200)	50-130(200)
Operating range	Cool Min - Max	°C	-10 ~ +52	-10 ~ +52	-10 ~ +52	-10 ~ +52	-10 ~ +52	-10 ~ +52
	Heat Min - Max	°C	-25 ~ +18	-25 ~ +18	-25 ~ +18	-25 ~ +18	-25 ~ +18	-25 ~ +18

HP			30 HP	32 HP	34 HP	36 HP	38 HP	40 HP
Outdoor unit			U-14ME2E8	U-16ME2E8	U-10ME2E8	U-12ME2E8	U-10ME2E8	U-12ME2E8
			U-16ME2E8	U-16ME2E8	U-12ME2E8	U-12ME2E8	U-12ME2E8	U-16ME2E8
Power supply	Voltage	V	380-400-415	380-400-415	380-400-415	380-400-415	380-400-415	380-400-415
	Phase		Three phase	Three phase	Three phase	Three phase	Three phase	Three phase
	Frequency	Hz	50	50	50	50	50	50
Cooling capacity	kW		85,0	90,0	96,0	101,0	107,0	113,0
EER ¹⁾	W/W		3,68	3,52	4,05	3,95	3,84	3,75
Current	A		38,60-36,60-35,30	42,30-40,20-38,70	38,70-36,80-35,50	41,40-39,30-37,90	46,10-43,80-42,20	49,20-46,70-45,00
Input power	kW		23,10	25,60	23,70	25,60	27,90	30,10
Heating capacity	kW		95,0	100,0	108,0	113,0	119,0	127,0
COP ¹⁾	W/W		4,48	4,42	4,72	4,73	4,61	4,57
Current	A		35,40-33,60-32,40	37,70-35,80-34,60	37,80-35,90-34,60	39,00-37,10-35,80	42,60-40,50-39,00	45,90-43,60-42,00
Input power	kW		21,20	22,60	22,90	23,90	25,80	27,80
Starting current	A		4,00	4,00	3,00	3,00	4,00	4,00
External static pressure (Max)	Pa		80	80	80	80	80	80
Air flow	m ³ /min		464	464	688	696	688	696
Sound pressure	Normal	dB(A)	63,5	64,0	63,0	64,0	64,0	64,5
	Silent mode	dB(A)	60,5	61,0	60,0	61,0	61,0	61,5
Sound power	Normal mode	dB(A)	84,5	85,0	84,0	85,0	85,0	85,5
Dimension / Net weight	HxWxD	mm / kg	1842x2420 x1000/630	1842x2420 x1000/630	1842x3250 x1000/750	1842x3660 x1000/810	1842x3250 x1000/795	1842x3660 x1000/855
Piping diameter ²⁾	Liquid	Inch (mm)	3/4(19,05)/ 7/8(22,22)	3/4(19,05)/ 7/8(22,22)	3/4(19,05)/ 7/8(22,22)	3/4(19,05)/ 7/8(22,22)	3/4(19,05)/ 7/8(22,22)	3/4(19,05)/ 7/8(22,22)
	Gas	Inch (mm)	1-1/4(31,75)/ 1-1/2(38,10)	1-1/4(31,75)/ 1-1/2(38,10)	1-1/4(31,75)/ 1-1/2(38,10)	1-1/2(38,10)/ 1-5/8(41,28)	1-1/2(38,10)/ 1-5/8(41,28)	1-1/2(38,10)/ 1-5/8(41,28)
	Balance	Inch (mm)	1/4(6,35)	1/4(6,35)	1/4(6,35)	1/4(6,35)	1/4(6,35)	1/4(6,35)
Refrigerant (R410A) / CO ₂ Eq.	kg / T		16,60/34,6608	16,60/34,6608	22,20/46,3536	24,90/51,9912	22,20/46,3536	24,90/46,3536
Maximum allowable indoor / outdoor capacity ratio ³⁾	%		50-130(200)	50-130(200)	50-130(200)	50-130(200)	50-130(200)	50-130(200)
Operating range	Cool Min - Max	°C	-10 ~ +52	-10 ~ +52	-10 ~ +52	-10 ~ +52	-10 ~ +52	-10 ~ +52
	Heat Min - Max	°C	-25 ~ +18	-25 ~ +18	-25 ~ +18	-25 ~ +18	-25 ~ +18	-25 ~ +18

Data is for reference. 1) EER and COP calculation is based in accordance to EN14511. 2) Piping diameter under 90 m for ultimate indoor unit / over 90 m for ultimate indoor unit (if the longest piping equivalent length exceeds 90 m, increase the sizes of the main tubes by 1 rank for gas tubes and liquid tubes). 3) If the following conditions are satisfied, the effective range is above 130% and below 200%: A. Obey the limited number of connectable indoor units. B. The lower limit of operating range for heating outdoor temperature is limited to -10 °C WB (standard -25 °C WB). C. Simultaneous operation is limited to less than 130% of connectable indoor units.

HP			42 HP	44 HP	46 HP	48 HP	50 HP	52 HP
			U-10ME2E8	U-12ME2E8	U-14ME2E8	U-16ME2E8	U-10ME2E8	U-12ME2E8
	Outdoor unit		U-16ME2E8	U-16ME2E8	U-16ME2E8	U-16ME2E8	U-12ME2E8	U-12ME2E8
			U-16ME2E8	U-16ME2E8	U-16ME2E8	U-16ME2E8	U-12ME2E8	U-16ME2E8
Power supply	Voltage	V	380 - 400 - 415	380 - 400 - 415	380 - 400 - 415	380 - 400 - 415	380 - 400 - 415	380 - 400 - 415
	Phase		Three phase	Three phase	Three phase	Three phase	Three phase	Three phase
	Frequency	Hz	50	50	50	50	50	50
Cooling capacity		kW	118,0	124,0	130,0	135,0	140,0	145,0
EER ¹⁾		W/W	3,69	3,62	3,62	3,52	3,87	3,82
Current		A	52,80 - 50,20 - 48,40	56,00 - 53,20 - 51,30	59,90 - 56,90 - 54,90	63,40 - 60,20 - 58,10	59,10 - 56,20 - 54,20	62,10 - 59,00 - 56,80
Input power		kW	32,00	34,30	35,90	38,40	36,20	38,00
Heating capacity		kW	132,0	138,0	145,0	150,0	155,0	160,0
COP ¹⁾		W/W	4,49	4,50	4,46	4,42	4,65	4,66
Current		A	49,10 - 46,60 - 44,90	50,70 - 48,20 - 46,40	54,30 - 51,50 - 49,70	56,60 - 53,80 - 51,80	55,00 - 52,20 - 50,40	56,60 - 53,80 - 51,90
Input power		kW	29,40	30,70	32,50	33,90	33,30	34,30
Starting current		A	5,00	5,00	6,00	6,00	5,00	5,00
External static pressure (Max)		Pa	80	80	80	80	80	80
Air flow		m ³ /min	688	696	696	696	920	928
Sound pressure	Normal	dB(A)	65,0	65,5	65,5	66,0	65,5	66,0
	Silent mode	dB(A)	62,0	62,5	62,5	63,0	62,5	63,0
Sound power	Normal mode	dB(A)	86,0	86,5	86,5	87,0	86,5	87,0
Dimension / Net weight	HxWxD	mm / kg	1842x3250 x1000/840	1842x3660 x1000/900	1842x3660 x1000/945	1842x3660 x1000/945	1842x4490 x1000/1065	1842x4900 x1000/1125
	Piping diameter ²⁾							
Piping diameter ²⁾	Liquid	Inch (mm)	3/4 (19,05) / 7/8 (22,22)	3/4 (19,05) / 7/8 (22,22)	3/4 (19,05) / 7/8 (22,22)	3/4 (19,05) / 7/8 (22,22)	3/4 (19,05) / 7/8 (22,22)	3/4 (19,05) / 7/8 (22,22)
	Gas	Inch (mm)	1-1/2 (38,10) / 1-5/8 (41,28)	1-1/2 (38,10) / 1-5/8 (41,28)	1-1/2 (38,10) / 1-5/8 (41,28)	1-1/2 (38,10) / 1-5/8 (41,28)	1-1/2 (38,10) / 1-5/8 (41,28)	1-1/2 (38,10) / 1-5/8 (41,28)
	Balance	Inch (mm)	1/4 (6,35)	1/4 (6,35)	1/4 (6,35)	1/4 (6,35)	1/4 (6,35)	1/4 (6,35)
Refrigerant (R410A) / CO ₂ Eq.		kg / T	22,20/51,9912	24,90/51,9912	24,90/51,9912	24,90/51,9912	30,50/63,6840	33,20/69,3216
Maximum allowable indoor / outdoor capacity ratio ³⁾		%	50 - 130 (200)	50 - 130 (200)	50 - 130 (200)	50 - 130 (200)	50 - 130 (200)	50 - 130 (200)
Operating range	Cool Min ~ Max	°C	-10 ~ +52	-10 ~ +52	-10 ~ +52	-10 ~ +52	-10 ~ +52	-10 ~ +52
	Heat Min ~ Max	°C	-25 ~ +18	-25 ~ +18	-25 ~ +18	-25 ~ +18	-25 ~ +18	-25 ~ +18

HP			54 HP	56 HP	58 HP	60 HP	62 HP	64 HP
			U-10ME2E8	U-12ME2E8	U-10ME2E8	U-12ME2E8	U-14ME2E8	U-16ME2E8
	Outdoor unit		U-12ME2E8	U-12ME2E8	U-16ME2E8	U-16ME2E8	U-16ME2E8	U-16ME2E8
			U-16ME2E8	U-16ME2E8	U-16ME2E8	U-16ME2E8	U-16ME2E8	U-16ME2E8
Power supply	Voltage	V	380 - 400 - 415	380 - 400 - 415	380 - 400 - 415	380 - 400 - 415	380 - 400 - 415	380 - 400 - 415
	Phase		Three phase	Three phase	Three phase	Three phase	Three phase	Three phase
	Frequency	Hz	50	50	50	50	50	50
Cooling capacity		kW	151,0	156,0	162,0	168,0	174,0	180,0
EER ¹⁾		W/W	3,75	3,71	3,65	3,60	3,60	3,52
Current		A	66,60 - 63,20 - 60,90	68,80 - 65,30 - 63,00	73,30 - 69,70 - 67,10	77,10 - 73,30 - 70,60	79,80 - 75,80 - 73,00	84,60 - 80,30 - 77,40
Input power		kW	40,30	42,10	44,40	46,70	48,30	51,20
Heating capacity		kW	169,0	175,0	182,0	189,0	195,0	201,0
COP ¹⁾		W/W	4,56	4,56	4,47	4,47	4,45	4,42
Current		A	61,90 - 58,80 - 56,70	63,40 - 60,20 - 58,10	68,00 - 64,60 - 62,20	70,60 - 67,10 - 64,70	73,10 - 69,50 - 67,00	76,00 - 72,20 - 69,60
Input power		kW	37,10	38,40	40,70	42,30	43,80	45,50
Starting current		A	6,00	6,00	7,00	7,00	8,00	8,00
External static pressure (Max)		Pa	80	80	80	80	80	80
Air flow		m ³ /min	920	928	920	928	928	928
Sound pressure	Normal	dB(A)	66,0	66,5	66,5	67,0	67,0	67,0
	Silent mode	dB(A)	63,0	63,5	63,5	64,0	64,0	64,0
Sound power	Normal mode	dB(A)	87,0	87,5	87,5	88,0	88,0	88,0
Dimension / Net weight	HxWxD	mm / kg	1842x4490 x1000/1110	1842x4900 x1000/1170	1842x4490 x1000/1155	1842x4900 x1000/1215	1842x4900 x1000/1260	1842x4900 x1000/1260
	Piping diameter ²⁾							
Piping diameter ²⁾	Liquid	Inch (mm)	3/4 (19,05) / 7/8 (22,22)	3/4 (19,05) / 7/8 (22,22)	3/4 (19,05) / 7/8 (22,22)	3/4 (19,05) / 7/8 (22,22)	3/4 (19,05) / 7/8 (22,22)	3/4 (19,05) / 7/8 (22,22)
	Gas	Inch (mm)	1-1/2 (38,10) / 1-5/8 (41,28)	1-1/2 (38,10) / 1-5/8 (41,28)	1-1/2 (38,10) / 1-5/8 (41,28)	1-1/2 (38,10) / 1-5/8 (41,28)	1-5/8 (41,28) / 1-3/4 (44,45)	1-5/8 (41,28) / 1-3/4 (44,45)
	Balance	Inch (mm)	1/4 (6,35)	1/4 (6,35)	1/4 (6,35)	1/4 (6,35)	1/4 (6,35)	1/4 (6,35)
Refrigerant (R410A) / CO ₂ Eq.		kg / T	30,50/63,6840	33,20/69,3216	30,50/63,6840	33,20/69,3216	33,20/69,3216	33,20/69,3216
Maximum allowable indoor / outdoor capacity ratio ³⁾		%	50 - 130 (200)	50 - 130 (200)	50 - 130 (200)	50 - 130 (200)	50 - 130 (200)	50 - 130 (200)
Operating range	Cool Min ~ Max	°C	-10 ~ +52	-10 ~ +52	-10 ~ +52	-10 ~ +52	-10 ~ +52	-10 ~ +52
	Heat Min ~ Max	°C	-25 ~ +18	-25 ~ +18	-25 ~ +18	-25 ~ +18	-25 ~ +18	-25 ~ +18

Data is for reference. 1) EER and COP calculation is based in accordance to EN14511. 2) Piping diameter under 90 m for ultimate indoor unit / over 90 m for ultimate indoor unit (if the longest piping equivalent length exceeds 90 m, increase the sizes of the main tubes by 1 rank for gas tubes and liquid tubes). 3) If the following conditions are satisfied, the effective range is above 130% and below 200%: A. Obey the limited number of connectable indoor units. B. The lower limit of operating range for heating outdoor temperature is limited to -10 °C WB [standard -25 °C WB]. C. Simultaneous operation is limited to less than 130% of connectable indoor units.

2-Pipe ECOi EX ME2 Series space saving model combination from 22 to 80 HP

HP			22 HP	24 HP	26 HP	28 HP	30 HP	32 HP	34 HP	
	Outdoor unit		U-10ME2E8 U-12ME2E8	U-12ME2E8 U-12ME2E8	U-10ME2E8 U-16ME2E8	U-12ME2E8 U-16ME2E8	U-14ME2E8 U-16ME2E8	U-16ME2E8 U-16ME2E8	U-16ME2E8 U-16ME2E8	U-14ME2E8 U-20ME2E8
Power supply	Voltage	V	380-400-415	380-400-415	380-400-415	380-400-415	380-400-415	380-400-415	380-400-415	380-400-415
	Phase		Three phase	Three phase	Three phase	Three phase	Three phase	Three phase	Three phase	Three phase
	Frequency	Hz	50	50	50	50	50	50	50	50
Cooling capacity		kW	61,5	68,0	73,0	78,5	85,0	90,0	96,0	
EER ¹⁾		W/W	4,13	3,93	3,80	3,69	3,68	3,52	3,56	
SEER ²⁾			6,90	6,86	6,62	6,60	6,88	6,55	7,21	
Current		A	24,30-23,10-22,30	28,00-26,60-25,60	31,70-30,10-29,00	34,80-33,10-31,90	38,60-36,60-35,30	42,30-40,20-38,70	44,10-41,90-40,40	
Input power		kW	14,90	17,30	19,20	21,30	23,10	25,60	27,00	
Heating capacity		kW	69,0	76,5	81,5	87,5	95,0	100,0	108,0	
COP ¹⁾		W/W	4,76	4,69	4,55	4,56	4,48	4,42	4,17	
SCOP ²⁾			4,53	4,78	4,16	4,29	4,13	4,09	4,14	
Current		A	23,90-22,70-21,90	26,60-25,30-24,40	29,90-28,40-27,40	31,70-30,10-29,00	35,40-33,60-32,40	37,70-35,80-34,60	42,80-40,60-39,20	
Input power		kW	14,50	16,30	17,90	19,20	21,20	22,60	25,90	
Starting current		A	2,00	2,00	3,00	3,00	4,00	4,00	4,00	
External static pressure (Max)		Pa	80	80	80	80	80	80	80	
Air flow		m ³ /min	456	464	456	464	464	464	637	
Sound pressure	Normal / Silent mode	dB(A)	61,0/58,0	62,0/59,0	62,5/59,5	63,5/60,5	63,5/60,5	64,0/61,0	63,0/60,0	
Sound power	Normal mode	dB(A)	82,0	83,0	83,5	84,5	84,5	85,0	84,0	
Dimension / Net weight	H x W x D	mm / kg	1842 x 2010 x 1000 / 480	1842 x 2420 x 1000 / 540	1842 x 2010 x 1000 / 525	1842 x 2420 x 1000 / 585	1842 x 2420 x 1000 / 630	1842 x 2420 x 1000 / 630	1842 x 2780 x 1000 / 690	
Piping diameter ³⁾	Liquid	Inch (mm)	5/8(15,88)/ 3/4(19,05)	5/8(15,88)/ 3/4(19,05)	3/4(19,05)/ 7/8(22,22)	3/4(19,05)/ 7/8(22,22)	3/4(19,05)/ 7/8(22,22)	3/4(19,05)/ 7/8(22,22)	3/4(19,05)/ 7/8(22,22)	
	Gas	Inch (mm)	1-1/8(28,58)/ 1-1/4(31,75)	1-1/8(28,58)/ 1-1/4(31,75)	1-1/4(31,75)/ 1-1/2(38,10)	1-1/4(31,75)/ 1-1/2(38,10)	1-1/4(31,75)/ 1-1/2(38,10)	1-1/4(31,75)/ 1-1/2(38,10)	1-1/4(31,75)/ 1-1/2(38,10)	
	Balance	Inch (mm)	1/4(6,35)	1/4(6,35)	1/4(6,35)	1/4(6,35)	1/4(6,35)	1/4(6,35)	1/4(6,35)	
Refrigerant (R410A) / CO ₂ Eq.		kg / T	13,90/23,3856	16,60/34,6608	13,90/29,0232	16,60/34,6608	16,60/34,6608	16,60/34,6608	17,80/37,1664	
Maximum allowable indoor / outdoor capacity ratio ⁴⁾		%	50 ~ 130(200)	50 ~ 130(200)	50 ~ 130(200)	50 ~ 130(200)	50 ~ 130(200)	50 ~ 130(200)	50 ~ 130(200)	
Operating range	Cool Min - Max	°C	-10 ~ +52	-10 ~ +52	-10 ~ +52	-10 ~ +52	-10 ~ +52	-10 ~ +52	-10 ~ +52	
	Heat Min - Max	°C	-25 ~ +18	-25 ~ +18	-25 ~ +18	-25 ~ +18	-25 ~ +18	-25 ~ +18	-25 ~ +18	

HP			36 HP	38 HP	40 HP	42 HP	44 HP	46 HP	48 HP	
	Outdoor unit		U-16ME2E8 U-20ME2E8	U-18ME2E8 U-20ME2E8	U-20ME2E8 U-20ME2E8	U-10ME2E8 U-16ME2E8	U-12ME2E8 U-16ME2E8	U-14ME2E8 U-16ME2E8	U-16ME2E8 U-16ME2E8	U-16ME2E8 U-16ME2E8
Power supply	Voltage	V	380-400-415	380-400-415	380-400-415	380-400-415	380-400-415	380-400-415	380-400-415	380-400-415
	Phase		Three phase	Three phase	Three phase	Three phase	Three phase	Three phase	Three phase	Three phase
	Frequency	Hz	50	50	50	50	50	50	50	50
Cooling capacity		kW	101,0	107,0	113,0	118,0	124,0	130,0	135,0	
EER ¹⁾		W/W	3,42	3,42	3,34	3,69	3,62	3,62	3,52	
SEER ²⁾			6,86	7,32	7,16	6,57	6,60	6,70	6,55	
Current		A	47,70-45,30-43,70	50,60-48,10-46,30	54,10-51,40-49,50	52,80-50,20-48,40	56,00-53,20-51,30	59,90-56,90-54,90	63,40-60,20-58,10	
Input power		kW	25,9	31,3	33,8	32,0	34,3	35,9	38,4	
Heating capacity		kW	113,0	119,0	127,0	132,0	138,0	145,0	150,0	
COP ¹⁾		W/W	4,14	4,13	3,92	4,49	4,50	4,46	4,42	
SCOP ²⁾			4,06	4,14	4,13	4,11	4,21	4,12	4,09	
Current		A	44,60-42,40-40,80	47,10-44,70-43,10	52,40-49,80-48,00	49,10-46,60-44,90	50,70-48,20-46,40	54,30-51,50-49,7	56,60-53,80-51,8	
Input power		kW	27,30	28,80	32,40	29,40	30,70	32,50	33,90	
Starting current		A	4,00	4,00	4,00	5,00	5,00	6,00	6,00	
External static pressure (Max)		Pa	80	80	80	80	80	80	80	
Air flow		m ³ /min	637	810	810	688	696	696	696	
Sound pressure	Normal / Silent mode	dB(A)	63,5/60,5	62,5/59,5	63,0/60,0	65,0/62,0	65,5/62,5	65,5/62,5	66,0/63,0	
Sound power	Normal mode	dB(A)	84,5	83,5	84,0	86,0	86,5	86,5	87,0	
Dimension / Net weight	H x W x D	mm / kg	1842 x 2780 x 1000 / 690	1842 x 3140 x 1000 / 750	1842 x 3140 x 1000 / 750	1842 x 3250 x 1000 / 840	1842 x 3660 x 1000 / 900	1842 x 3660 x 1000 / 945	1842 x 3660 x 1000 / 945	
Piping diameter ³⁾	Liquid	Inch (mm)	3/4(19,05)/ 7/8(22,22)	3/4(19,05)/ 7/8(22,22)	3/4(19,05)/ 7/8(22,22)	3/4(19,05)/ 7/8(22,22)	3/4(19,05)/ 7/8(22,22)	3/4(19,05)/ 7/8(22,22)	3/4(19,05)/ 7/8(22,22)	
	Gas	Inch (mm)	1-1/2(38,10)/ 1-5/8(41,28)	1-1/2(38,10)/ 1-5/8(41,28)	1-1/2(38,10)/ 1-5/8(41,28)	1-1/2(38,10)/ 1-5/8(41,28)	1-1/2(38,10)/ 1-5/8(41,28)	1-1/2(38,10)/ 1-5/8(41,28)	1-1/2(38,10)/ 1-5/8(41,28)	
	Balance	Inch (mm)	1/4(6,35)	1/4(6,35)	1/4(6,35)	1/4(6,35)	1/4(6,35)	1/4(6,35)	1/4(6,35)	
Refrigerant (R410A) / CO ₂ Eq.		kg / T	17,80/37,1664	19,00/39,672	19,00/39,672	22,20/46,3536	24,90/51,9912	24,90/51,9912	24,90/51,9912	
Maximum allowable indoor / outdoor capacity ratio ⁴⁾		%	50 ~ 130(200)	50 ~ 130(200)	50 ~ 130(200)	50 ~ 130(200)	50 ~ 130(200)	50 ~ 130(200)	50 ~ 130(200)	
Operating range	Cool Min - Max	°C	-10 ~ +52	-10 ~ +52	-10 ~ +52	-10 ~ +52	-10 ~ +52	-10 ~ +52	-10 ~ +52	
	Heat Min - Max	°C	-25 ~ +18	-25 ~ +18	-25 ~ +18	-25 ~ +18	-25 ~ +18	-25 ~ +18	-25 ~ +18	

1) EER and COP calculation is based in accordance to EN14511. 2) SEER / SCOP is calculated based on the seasonal space cooling / heating efficiency "η" values of the COMMISSION REGULATION (EU) 2016/2281. SEER, SCOP = (η + Correction) × PEF. 3) Piping diameter under 90 m for ultimate indoor unit / over 90 m for ultimate indoor unit (if the longest piping equivalent length exceeds 90 m, increase the sizes of the main tubes by 1 rank for gas tubes and liquid tubes). 4) If the following conditions are satisfied, the effective range is above 130% and below 200%: A. Obey the limited number of connectable indoor units. B. The lower limit of operating range for heating outdoor temperature is limited to -10 °C WB (standard -25 °C WB). C. Simultaneous operation is limited to less than 130% of connectable indoor units.

HP			50 HP	52 HP	54 HP	56 HP	58 HP	60 HP	62 HP	64 HP
			U-14ME2E8	U-16ME2E8	U-14ME2E8	U-16ME2E8	U-18ME2E8	U-20ME2E8	U-14ME2E8	U-16ME2E8
	Outdoor unit		U-16ME2E8	U-16ME2E8	U-20ME2E8	U-20ME2E8	U-20ME2E8	U-20ME2E8	U-16ME2E8	U-16ME2E8
			U-20ME2E8	U-20ME2E8	U-20ME2E8	U-20ME2E8	U-20ME2E8	U-20ME2E8	U-16ME2E8	U-16ME2E8
Power supply	Voltage	V	380-400-415	380-400-415	380-400-415	380-400-415	380-400-415	380-400-415	380-400-415	380-400-415
	Phase		Three phase	Three phase	Three phase	Three phase	Three phase	Three phase	Three phase	Three phase
	Frequency	Hz	50	50	50	50	50	50	50	50
Cooling capacity		kW	140,0	145,0	151,0	156,0	162,0	168,0	174,0	180,0
EER ¹⁾		W/W	3,55	3,46	3,49	3,41	3,40	3,35	3,60	3,52
SEER ²⁾			6,96	6,72	7,16	6,92	7,30	7,16	6,68	6,55
Current		A	64,40-61,10-58,90	68,50-65,00-62,70	70,00-66,50-64,10	74,00-70,30-67,80	76,90-73,10-70,40	80,10-76,10-73,40	79,80-75,80-73,00	84,60-80,30-77,40
Input power		kW	39,40	41,90	43,30	45,80	47,60	50,10	48,30	51,20
Heating capacity		kW	155,0	160,0	169,0	175,0	182,0	189,0	195,0	201,0
COP ¹⁾		W/W	4,29	4,27	4,11	4,08	4,06	3,94	4,45	4,42
SCOP ²⁾			4,08	4,05	4,13	4,07	4,13	4,13	4,11	4,09
Current		A	59,60-56,60-54,60	61,90-58,80-56,70	67,10-63,80-61,50	70,10-66,60-64,20	73,20-69,50-67,00	77,60-73,70-71,00	73,10-69,50-67,00	76,00-72,20-69,6
Input power		kW	36,10	37,50	41,10	42,90	44,80	48,00	43,80	45,50
Starting current		A	6,00	6,00	6,00	6,00	6,00	6,00	8,00	8,00
External static pressure (Max)		Pa	80	80	80	80	80	80	80	80
Air flow		m ³ /min	869	869	1042	1042	1215	1215	928	928
Sound pressure	Normal / Silent mode	dB(A)	65,5/62,5	65,5/62,5	65,0/62,0	65,5/62,5	64,5/61,5	65,0/62,0	67,0/64,0	67,0/64,0
Sound power	Normal mode	dB(A)	86,5	86,5	86,0	86,5	85,5	86,0	88,0	88,0
Dimension / Net weight	H x W x D	mm / kg	1842 x 4020 x 1000/1005	1842 x 4020 x 1000/1005	1842 x 4380 x 1000/1065	1842 x 4380 x 1000/1065	1842 x 4740 x 1000/1125	1842 x 4740 x 1000/1125	1842 x 4900 x 1000/1260	1842 x 4900 x 1000/1260
	Liquid	Inch (mm)	3/4(19,05)/7/8(22,22)	3/4(19,05)/7/8(22,22)	3/4(19,05)/7/8(22,22)	3/4(19,05)/7/8(22,22)	3/4(19,05)/7/8(22,22)	3/4(19,05)/7/8(22,22)	3/4(19,05)/7/8(22,22)	3/4(19,05)/7/8(22,22)
Piping diameter ³⁾	Gas	Inch (mm)	1-1/2(38,10)/1-5/8(41,28)	1-1/2(38,10)/1-5/8(41,28)	1-1/2(38,10)/1-5/8(41,28)	1-1/2(38,10)/1-5/8(41,28)	1-1/2(38,10)/1-5/8(41,28)	1-1/2(38,10)/1-5/8(41,28)	1-5/8(41,28)/1-3/4(44,45)	1-5/8(41,28)/1-3/4(44,45)
	Balance	Inch (mm)	1/4(6,35)	1/4(6,35)	1/4(6,35)	1/4(6,35)	1/4(6,35)	1/4(6,35)	1/4(6,35)	1/4(6,35)
Refrigerant (R410A) / CO ₂ Eq.		kg / T	26,10/54,4968	26,10/54,4968	27,30/57,0024	27,30/57,0024	28,50/59,508	28,50/59,508	33,20/69,3216	33,20/69,3216
Maximum allowable indoor / outdoor capacity ratio ⁴⁾		%	50 ~ 130(200)	50 ~ 130(200)	50 ~ 130(200)	50 ~ 130(200)	50 ~ 130(200)	50 ~ 130(200)	50 ~ 130(200)	50 ~ 130(200)
Operating range	Cool Min ~ Max	°C	-10 ~ +52	-10 ~ +52	-10 ~ +52	-10 ~ +52	-10 ~ +52	-10 ~ +52	-10 ~ +52	-10 ~ +52
	Heat Min ~ Max	°C	-25 ~ +18	-25 ~ +18	-25 ~ +18	-25 ~ +18	-25 ~ +18	-25 ~ +18	-25 ~ +18	-25 ~ +18

HP			66 HP	68 HP	70 HP	72 HP	74 HP	76 HP	78 HP	80 HP
			U-10ME2E8	U-12ME2E8	U-10ME2E8	U-16ME2E8	U-16ME2E8	U-16ME2E8	U-18ME2E8	U-20ME2E8
	Outdoor unit		U-16ME2E8	U-16ME2E8	U-20ME2E8	U-16ME2E8	U-18ME2E8	U-20ME2E8	U-20ME2E8	U-20ME2E8
			U-20ME2E8	U-20ME2E8	U-20ME2E8	U-20ME2E8	U-20ME2E8	U-20ME2E8	U-20ME2E8	U-20ME2E8
Power supply	Voltage	V	380-400-415	380-400-415	380-400-415	380-400-415	380-400-415	380-400-415	380-400-415	380-400-415
	Phase		Three phase	Three phase	Three phase	Three phase	Three phase	Three phase	Three phase	Three phase
	Frequency	Hz	50	50	50	50	50	50	50	50
Cooling capacity		kW	185,0	190,0	196,0	202,0	208,0	213,0	219,0	224,0
EER ¹⁾		W/W	3,52	3,49	3,47	3,42	3,42	3,39	3,38	3,35
SEER ²⁾			6,92	6,91	7,09	6,86	7,03	7,01	7,18	7,16
Current		A	85,00-80,80-77,80	88,10-83,70-80,70	91,30-86,80-83,60	95,40-90,60-87,30	98,30-93,40-90,00	101,70-96,60-93,10	103,50-98,30-94,70	106,80-101,50-97,80
Input power		kW	52,60	54,50	56,50	59,00	60,80	62,90	64,70	66,80
Heating capacity		kW	207,0	213,0	219,0	226,0	233,0	239,0	245,0	252,0
COP ¹⁾		W/W	4,16	4,18	4,05	4,14	4,12	4,03	4,03	3,94
SCOP ²⁾			4,11	4,17	4,13	4,06	4,12	4,07	4,13	4,13
Current		A	81,20-77,10-74,30	83,30-79,20-76,30	87,40-83,10-80,10	89,20-84,70-81,70	92,30-87,70-84,50	96,90-92,00-88,70	98,30-93,40-90,00	103,40-98,30-94,70
Input power		kW	49,70	51,00	54,10	56,60	56,50	59,30	60,80	64,00
Starting current		A	7,00	7,00	7,00	8,00	8,00	8,00	8,00	8,00
External static pressure (Max)		Pa	80	80	80	80	80	80	80	80
Air flow		m ³ /min	1266	1274	1439	1274	1447	1447	1620	1620
Sound pressure	Normal / Silent mode	dB(A)	66,0/63,0	66,5/63,5	65,5/62,5	66,5/63,5	66,5/63,5	66,5/63,5	66,0/63,0	66,0/63,0
Sound power	Normal mode	dB(A)	87,0	87,5	86,5	87,5	87,5	87,5	87,0	87,0
Dimension / Net weight	H x W x D	mm / kg	1842 x 5210 x 1000/1275	1842 x 5620 x 1000/1335	1842 x 5570 x 1000/1335	1842 x 5620 x 1000/1380	1842 x 5980 x 1000/1440	1842 x 5980 x 1000/1440	1842 x 6340 x 1000/1500	1842 x 6340 x 1000/1500
	Liquid	Inch (mm)	3/4(19,05)/7/8(22,22)	7/8(22,22)/1(25,04)	7/8(22,22)/1(25,04)	7/8(22,22)/1(25,04)	7/8(22,22)/1(25,04)	7/8(22,22)/1(25,04)	7/8(22,22)/1(25,04)	7/8(22,22)/1(25,04)
Piping diameter ³⁾	Gas	Inch (mm)	1-5/8(41,28)/1-3/4(44,45)	1-5/8(41,28)/1-3/4(44,45)	1-5/8(41,28)/1-3/4(44,45)	1-3/4(44,45)/2(50,80)	1-3/4(44,45)/2(50,80)	1-3/4(44,45)/2(50,80)	1-3/4(44,45)/2(50,80)	1-3/4(44,45)/2(50,80)
	Balance	Inch (mm)	1/4(6,35)	1/4(6,35)	1/4(6,35)	1/4(6,35)	1/4(6,35)	1/4(6,35)	1/4(6,35)	1/4(6,35)
Refrigerant (R410A) / CO ₂ Eq.		kg / T	32,90/68,6952	35,60/74,3328	34,10/19,836	35,80/68,6952	36,80/76,8384	36,80/76,8384	38,00/79,344	38,00/79,344
Maximum allowable indoor / outdoor capacity ratio ⁴⁾		%	50 ~ 130(200)	50 ~ 130(200)	50 ~ 130(200)	50 ~ 130(200)	50 ~ 130(200)	50 ~ 130(200)	50 ~ 130(200)	50 ~ 130(200)
Operating range	Cool Min ~ Max	°C	-10 ~ +52	-10 ~ +52	-10 ~ +52	-10 ~ +52	-10 ~ +52	-10 ~ +52	-10 ~ +52	-10 ~ +52
	Heat Min ~ Max	°C	-25 ~ +18	-25 ~ +18	-25 ~ +18	-25 ~ +18	-25 ~ +18	-25 ~ +18	-25 ~ +18	-25 ~ +18

1) EER and COP calculation is based in accordance to EN14511. 2) SEER / SCOP is calculated based on the seasonal space cooling / heating efficiency "η" values of the COMMISSION REGULATION (EU) 2016/2281. SEER, SCOP = (η + Correction) × PEF. 3) Piping diameter under 90 m for ultimate indoor unit / over 90 m for ultimate indoor unit (if the longest piping equivalent length exceeds 90 m, increase the sizes of the main tubes by 1 rank for gas tubes and liquid tubes). 4) If the following conditions are satisfied, the effective range is above 130% and below 200%: A. Obey the limited number of connectable indoor units. B. The lower limit of operating range for heating outdoor temperature is limited to -10 °C WB (standard -25 °C WB). C. Simultaneous operation is limited to less than 130% of connectable indoor units.

Rating conditions: Cooling indoor 27 °C DB / 19 °C WB. Cooling outdoor 35 °C DB / 24 °C WB. Heating indoor 20 °C DB. Heating outdoor 7 °C DB / 6 °C WB. (DB: Dry Bulb, WB: Wet Bulb). Specifications subject to change without notice. For detailed information about ErP / Energy Labelling, please visit our websites www.aircon.panasonic.eu or www.ptc.panasonic.eu.

3-Pipe ECOi EX MF3 Series



Simultaneous heating and cooling VRF system.
 The Panasonic 3-Pipe ECOi EX MF3 Series offers the best solution for the most discerning customers and demanding installations.

Simultaneous heating and cooling VRF System

The Panasonic 3-Pipe ECOi EX MF3 Series offers the ideal solution to meet customer's demands.

Upgraded energy efficiency utilized ECOi EX technology.

- SEER / SCOP improved in full capacities from 8 to 16 HP
- SEER / SCOP follows LOT21 (January 2018)
- Eurovent certified EER / COP

Design flexibility.

- High reliability even under extreme temperature conditions
- Connection of up to 52 indoor units
- Slim heat recovery box with just 200 mm height
- Farthest piping length between indoor and outdoor units: 200 m

Excellent seasonal energy saving.

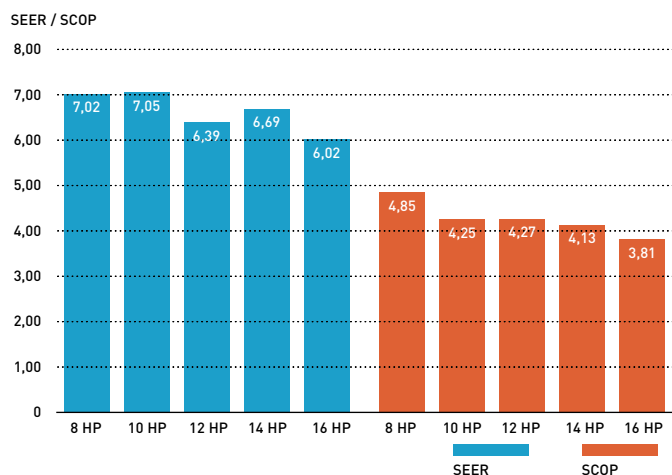

Extended design operation conditions

Cooling design operation conditions: The cooling operating range has been extended to -10 °C ~ 52 °C by changing the outdoor fan to an Inverter type.

Heating design operation conditions: Stable heating operation even with an outside air temperature of -20 °C. The heating operating range has been extended to -20 °C by use of a compressor with a high-pressure vessel.

Cooling design operation conditions.

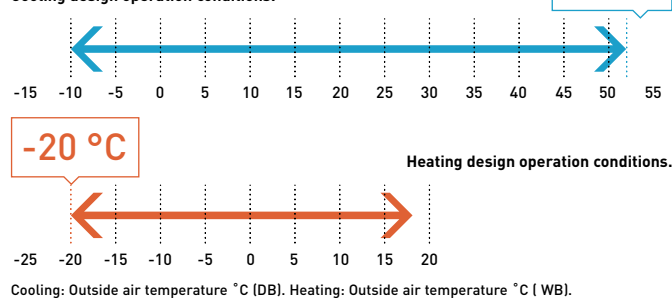

Wide temperature setting range

Wired remote controller heating temperature setting range is 16 to 30 °C as standard.

Increased maximum number of connectable indoor units

Maximum 48 HP with 52 indoor units can be set up according to user needs. Connectable indoor / outdoor unit capacity ratio up to 150%.

System (HP)	8	10	12	14	16	18	20	22	24	26	28	30	32	34	36	38	40	42	44	46	48
Connectable indoor units*: 150%	19	24	29	34	39	43	48	52					52								

*Depending on indoor units types. Please check service manuals.

Power suppression control for energy saving (demand control) ¹⁾

The 3-Pipe ECOi EX MF3 Series has a built-in demand function which uses the Inverter characteristics. With this demand function, the power consumption can be set in three steps, and operation ²⁾ at optimum performance is performed according to the setting and the power consumption. This function is useful to reduce the annual power consumption and to save electricity costs while maintaining comfort.

1) An outdoor Seri-Para I/O unit is required for demand input.

2) Setting is possible as 0% or in the range from 40 to 100% (in steps of 5%). At the time of shipping, setting has been done to the three steps of 0%, 70%, and 100%.

Slim 3-Pipe control box kit / Multiple connection type

Heat recovery Box to connect multiple indoor units with just one box, 4, 6 and up to 8 indoor units or groups.

The height is only 200 mm, which is especially advantageous in hotel applications, where space for connecting several boxes is limited.

Individual control of multiple indoor units with solenoid valve kits.

- Any design and layout can be used in a single system.
- Cooling operation is possible with an outdoor temperature of -10 °C.

System structure.

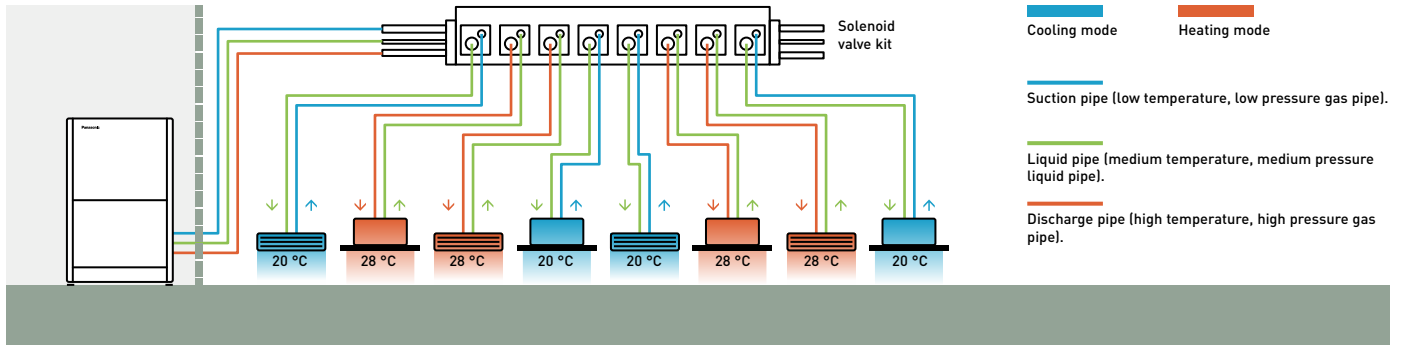

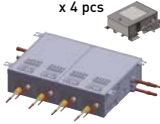
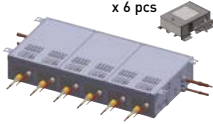
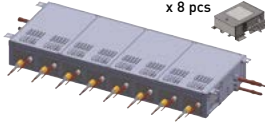
				
	1 port	4 port	6 port	8 port
56 type	CZ-P56HR3	CZ-P456HR3	CZ-P656HR3	CZ-P856HR3
160 type	CZ-P160HR3	CZ-P4160HR3	—	—

Solenoid valve kit / wiring work

Single connection type.

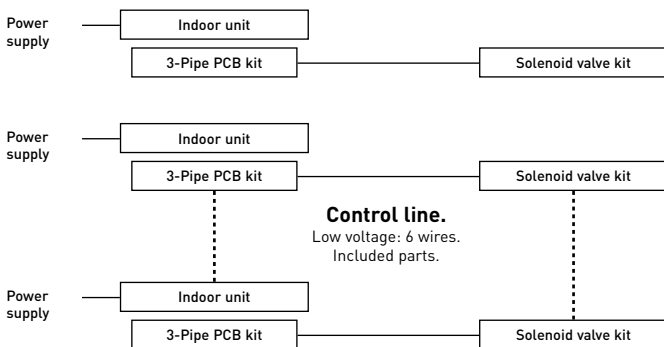

Multiple connection type.

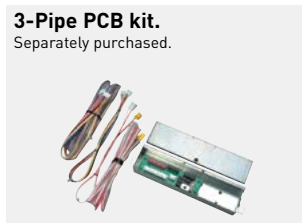
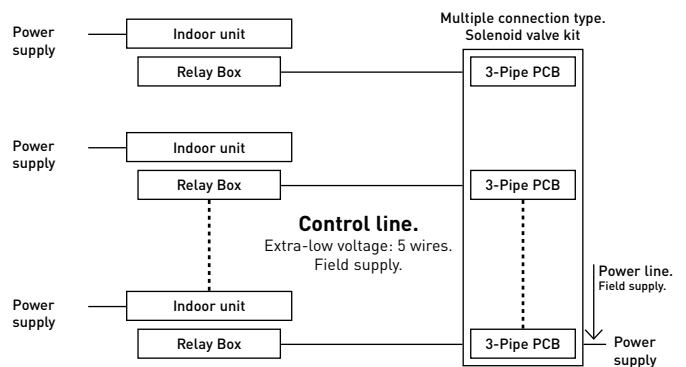

3-Pipe ECOi EX MF3 Series superior flexibility

Increased piping lengths and design flexibility

Adaptable to various building types and sizes. Actual piping length: 200 m. Maximum piping length: 500 m.

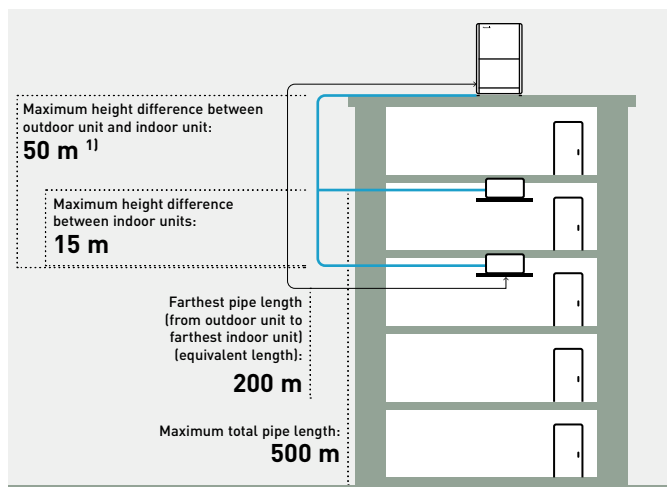

1) 40 m if the outdoor unit is below the indoor unit.

Up to 40 m piping after first branch

Up to 52 units can be connected to one system. Flexible piping layout makes it easier to design systems for locations such as train stations, airports, schools and hospitals.

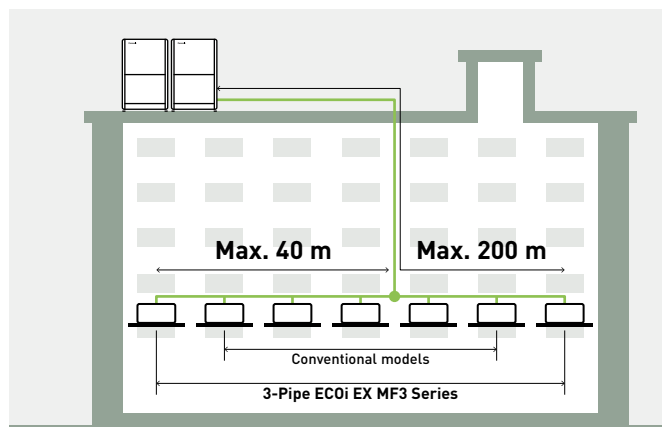

Excellent cost saving and smaller piping size

By using R410A with low pressure loss, pipe sizes for discharge, suction and liquid are all reduced. This makes it possible to aim for reduced piping space, improved workability at the site, and reduction of the piping material costs.

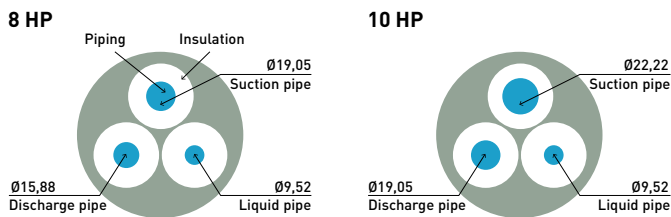

High external static pressure on condensers

With an efficient fan shape, fan guard, motor, and casing, the models can be custom-installed on-site to provide up to 80 Pa of external static pressure.

An air discharge duct prevents air flow short-circuiting, allowing outdoor units to be installed on every floor of a building.



Fan.

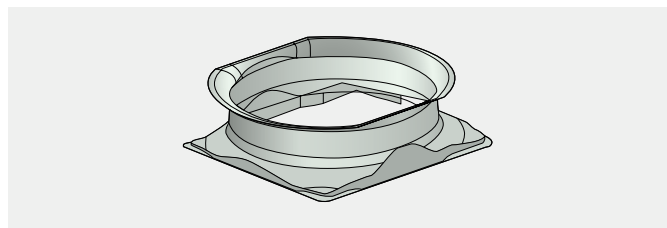

Bell-mouth casing.

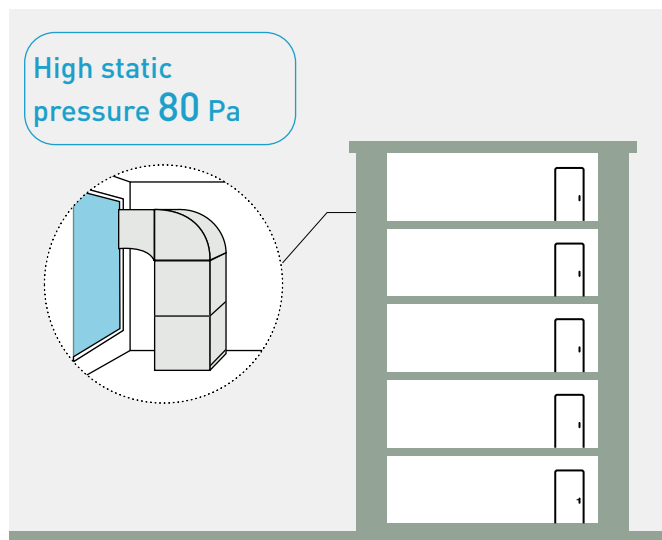

3-Pipe ECOi EX MF3 Series piping design

Select installation locations so that the lengths and sizes of refrigerant piping are within the allowable ranges shown in the figure below.

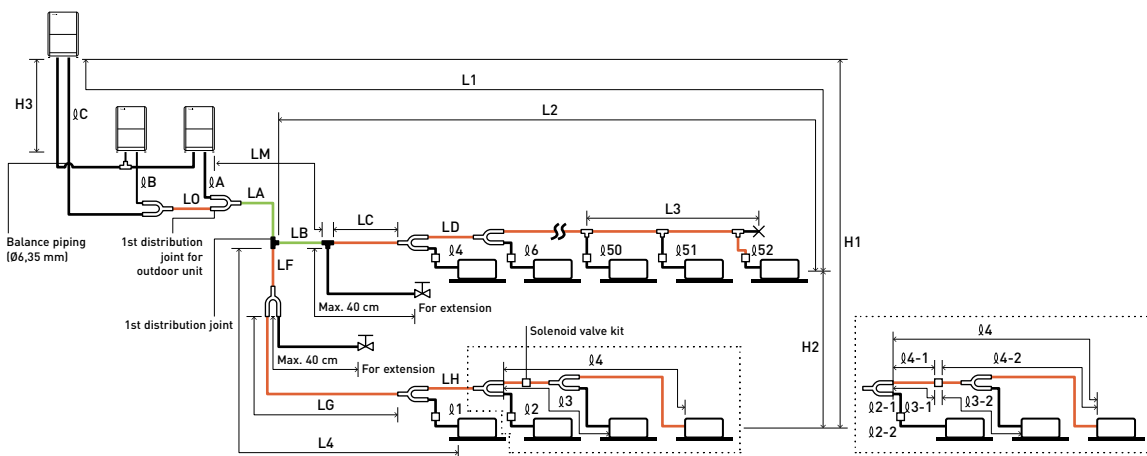

The outdoor connection main piping (LO portion) is determined by the total capacity of the outdoor units that are connected to the tube ends.
 Note: Be sure to use special R410A distribution joints (CZ: optional parts) for outdoor unit connections and piping branches.

R410A distribution joint.
 CZ-P680PJ2BM (for outdoor unit)
 CZ-P1350PJ2BM (for outdoor unit)
 CZ-P224BH2BM (for indoor unit)
 CZ-P680BH2BM (for indoor unit)
 CZ-P1350BH2BM (for indoor unit)

Main piping length (maximum piping size) LM= LA + LB ...

Main distribution tubes LC - LH are selected according to the capacity after the distribution joint.

Sizes of indoor unit connection piping $\phi 1 - \phi 52$ are determined by the connection piping sizes on the indoor units.

Distribution joint (CZ: optional parts).

Ball valve (field supply).

T-joint (field supply).

Solidly welded shut (pinch weld).

Ranges that apply to refrigerant piping lengths and to differences in installation heights

Items	Mark	Contents	Length (m)
Allowable piping length	L1	Maximum piping length	Actual length $\leq 200^{1)}$ Equivalent length $\leq 210^{1)}$
	ΔL (L2-L4)	Difference between maximum length and minimum length from the 1st distribution joint	$\leq 50^{2)}$
	LM	Maximum length of main piping (at maximum size) * Even after 1st distribution joint, LM is allowed if at maximum piping length.	— ³⁾
	$\phi 1, \phi 2 - \phi 52$	Maximum length of each distribution tube	$\leq 50^{4)}$
	$L1 + \phi 1 + \phi 2 - \phi 51 + \phi A + \phi B + LF + LG + LH$	Total maximum piping length including length of each distribution tube (only liquid piping)	≤ 500
Allowable elevation difference	$\phi A, \phi B + LO, \phi C + LO$	Maximum piping length from outdoor's 1st distribution joint to each outdoor unit	≤ 10
	$\phi 1-2, \phi 2-2 - \phi 52-2$	Maximum length between solenoid valve kit and indoor unit	≤ 30
	H1	When outdoor unit is installed higher than indoor unit	≤ 50
	H2	When outdoor unit is installed lower than indoor unit	≤ 40
Allowable length of joint piping	H3	Maximum difference between indoor units	$\leq 15^{5)}$
	H3	Maximum difference between outdoor units	≤ 4
Allowable length of joint piping	L3	T-joint piping (field-supply); Maximum piping length between the first T-joint and solidly welded-shut end point	≤ 2

L = Length, H = Height

1) If the longest piping length (L1) exceeds 90 m (equivalent length), increase the sizes of the main pipes (LM) by 1 rank for suction pipes, discharge pipes and liquid pipes. Use a field supply reducer. Select the pipe size from the table of main piping sizes (Table 3) and from the table of refrigerant piping sizes (Table 8). 2) If the longest main piping length (LM) exceeds 50 m, increase the main piping size at the portion before 50 m by 1 rank for the suction pipes and discharge pipes. Use a field supply reducer. Determine the length less than the limitation of allowable maximum piping length. For the portion that exceeds 50 m, set based on the main piping size (LA) listed in Table 3. 3) If the piping length marked "L" (L2-L4) exceeds 40 m, increase the piping size at the portion after the 1st distribution joint by 1 rank for the liquid pipe, suction pipe and discharge pipe. Refer to the Technical Data for the details. 4) If any of the piping length exceeds 30 m, increase the size of the suction pipes, discharge pipes and liquid pipes by 1 rank.

* The outdoor connection main piping (LO portion) is determined by the total capacity of the outdoor units that are connected to the pipe ends.

System limitations.

Maximum number allowable connected outdoor units	3
Maximum capacity allowable connected outdoor units	135 kW (48 HP)
Maximum connectable indoor units	52
Maximum allowable indoor / outdoor capacity ratio	50-150%

1) In the case of 24 HP (type 68 kW) or smaller units, the number is limited by the total capacity of the connected indoor units.

2) Up to 3 units can be connected if the system has been extended.

3) It is strongly recommended that you choose the unit so the load can become between 50 and 130%.

Additional refrigerant charge.

Liquid piping size (Inch (mm))	1/4 (6,35)	3/8 (9,52)	1/2 (12,70)	5/8 (15,88)	3/4 (19,05)	7/8 (22,22)
Amount of refrigerant charge (g/m)	26	56	128	185	259	366

Necessary amount of additional refrigerant charge per meter, according to discharge piping size.

Discharge piping size	Inch (mm)	1/2 (12,70)	5/8 (15,88)	3/4 (19,05)	7/8 (22,22)	1 (25,40)	1-1/8 (28,58)	1-1/4 (31,75)	1-1/2 (38,10)
Additional amount	g/m	12	21	31	41	55	71	89	126

Refrigerant piping.

Piping size (mm)				Material Temper - 0				Material Temper - 1/2 H, H			
$\phi 6,35$	t 0,8	$\phi 12,70$	t 0,8	$\phi 19,05$	t 1,2	$\phi 22,22$	t 1,0	$\phi 28,58$	t 1,0	$\phi 38,10$	t 1,15
$\phi 9,52$	t 0,8	$\phi 15,88$	t 1,0			$\phi 25,40$	t 1,0	$\phi 31,75$	t 1,1	$\phi 41,28$	t 1,20

* When bending the tubes, use a bending radius that is at least 4 times the outer diameter of the tubes. In addition, take sufficient care to avoid crushing or damaging the tubes when bending them.

3-Pipe ECOi EX MF3 Series

Simultaneous heating and cooling operation with heat recovery type.

The 3-Pipe ECOi EX MF3 Series is one of the most advanced VRF systems.

Not only highly efficient performance for simultaneous heating and cooling, but also sophisticated installation and maintenance capability.

4,85
SCOP



HP			8 HP	10 HP	12 HP	14 HP	16 HP
Outdoor unit			U-8MF3E8	U-10MF3E8	U-12MF3E8	U-14MF3E8	U-16MF3E8
Power supply	Voltage	V	380-400-415	380-400-415	380-400-415	380-400-415	380-400-415
	Phase		Three phase	Three phase	Three phase	Three phase	Three phase
	Frequency	Hz	50	50	50	50	50
Cooling capacity		kW	22,4	28,0	33,5	40,0	45,0
EER ¹⁾		W/W	5,11	4,72	3,91	3,70	3,49
Current		A	7,16 - 6,80 - 6,55	9,90 - 9,41 - 9,07	3,19 - 13,20 - 12,70	18,20 - 17,30 - 16,70	21,30 - 20,20 - 19,50
Input power		kW	4,38	5,93	8,57	10,80	12,90
Heating capacity		kW	25,0	31,5	37,5	45,0	50,0
COP ¹⁾		W/W	5,25	5,17	4,51	4,21	4,17
Current		A	7,78 - 7,39 - 7,12	10,20 - 9,66 - 9,31	13,40 - 12,80 - 12,30	18,10 - 17,20 - 16,50	20,00 - 19,00 - 18,30
Input power		kW	4,76	6,09	8,32	10,70	12,00
Starting current		A	1,00	1,00	1,00	2,00	2,00
External static pressure (Max)		Pa	80	80	80	80	80
Air flow		m ³ /min	210	220	232	232	232
Sound pressure	Normal mode	dB(A)	54,0	57,0	60,0	61,0	62,0
	Silent mode 1 / 2	dB(A)	51,0/49,0	54,0/52,0	57,0/55,0	58,0/56,0	59,0/57,0
Sound power	Normal mode	dB(A)	76,0	78,0	81,0	82,0	82,0
Dimension	HxWxD	mm	1842x1180x1000	1842x1180x1000	1842x1180x1000	1842x1180x1000	1842x1180x1000
Net weight		kg	261	262	286	334	334
Piping diameter ²⁾	Liquid	Inch (mm)	3/8(9,52)/1/2(12,70)	3/8(9,52)/1/2(12,70)	1/2(12,70)/5/8(15,88)	1/2(12,70)/5/8(15,88)	1/2(12,70)/5/8(15,88)
	Discharge	Inch (mm)	5/8(15,88)/3/4(19,05)	3/4(19,05)/7/8(22,22)	3/4(19,05)/7/8(22,22)	7/8(22,22)/1(25,40)	7/8(22,22)/1(25,40)
	Suction	Inch (mm)	3/4(19,05)/7/8(22,22)	7/8(22,22)/1(25,40)	1(25,40)/1-1/8(28,58)	1(25,40)/1-1/8(28,58)	1-1/8(28,58)/1-1/4(31,75)
	Balance	Inch (mm)	1/4(6,35)	1/4(6,35)	1/4(6,35)	1/4(6,35)	1/4(6,35)
Refrigerant (R410A) / CO ₂ Eq.	kg / T		6,80/14,1984	6,80/14,1984	8,30/17,3304	8,30/17,3304	8,30/17,3304
Maximum allowable indoor / outdoor capacity ratio		%	50 - 150	50 - 150	50 - 150	50 - 150	50 - 150
Operating range	Cool Min - Max	°C	-10 ~ +52	-10 ~ +52	-10 ~ +52	-10 ~ +52	-10 ~ +52
	Heat Min - Max	°C	-20 ~ +18	-20 ~ +18	-20 ~ +18	-20 ~ +18	-20 ~ +18
	Simultaneous op.	°C	-10 ~ +24	-10 ~ +24	-10 ~ +24	-10 ~ +24	-10 ~ +24

ErP data ³⁾

SEER ⁴⁾	7,02	7,05	6,39	6,69	6,02
$\eta_{s,c}$	277,7%	278,9%	252,7%	264,4%	237,7%
SCOP ⁴⁾	4,85	4,25	4,27	4,13	3,81
$\eta_{s,h}$	190,9%	166,8%	167,8%	162,1%	149,3%

1) EER and COP calculation is based in accordance to EN14511. 2) Piping diameter under 90 m for ultimate indoor unit / over 90 m for ultimate indoor unit (if the longest piping equivalent length exceeds 90 m, increase the sizes of the main tubes by 1 rank for gas tubes and liquid tubes). 3) SEER / SCOP and $\eta_{s,c}$ / $\eta_{s,h}$ are in accordance with ErP test data for F2 type variable static pressure hide-away indoor units. 4) SEER / SCOP is calculated based on the seasonal space cooling / heating efficiency "η" values of the COMMISSION REGULATION (EU) 2016/2281. SEER, SCOP = (η + Correction) × PEF.

Solenoid valve kit

KIT-P56HR3	3-Pipe control solenoid valve kit (up to 5,6 kW)
CZ-P56HR3	Solenoid valve kit (up to 5,6 kW)
CZ-CAPE2	3-Pipe control PCB
KIT-P160HR3	3-Pipe control solenoid valve kit (from 5,6 to 16,0 kW)
CZ-P160HR3	Solenoid valve kit (from 5,6 kW to 16,0 kW)
CZ-CAPE2	3-Pipe control PCB
CZ-CAPEK2 ⁵⁾	3-Pipe control PCB for wall-mounted

3-Pipe control box kit

CZ-P456HR3	4 ports 3 pipe box (up to 5,6 kW per port)
CZ-P656HR3	6 ports 3 pipe box (up to 5,6 kW per port)
CZ-P856HR3	8 ports 3 pipe box (up to 5,6 kW per port)
CZ-P4160HR3	4 ports 3 pipe box (up to 16,0 kW per port)

5) Available for S-45/56/73/106MK2E5B.



- Achieving SCOP 4,85 top class in the industry (LOT21 Seasonal heating efficiency value for 8 HP outdoor unit)
- Simultaneous cooling and heating operation with up to 39 indoor units
- Slim heat recovery boxes with just 200 mm height fit with the ceiling space limited in hotel applications

Technical focus

- High SEER / SCOP at full Load capacity (follows LOT21)
- Eurovent certified EER / COP
- Standardisation of outdoor unit to one compact casing size
- Connection of up to 52 indoor units
- High external static pressure 80 Pa with an efficient fan shape, fan guard, motor, and casing
- Silent outdoor unit operation: Minimum 54 dB(A) for 8 HP
- Bluefin coil coating as standard

3-Pipe ECOi EX MF3 Series combination from 18 to 48 HP

HP		18 HP	20 HP	22 HP	24 HP	26 HP	28 HP	30 HP	32 HP
Outdoor unit		U-8MF3E8	U-8MF3E8	U-10MF3E8	U-12MF3E8	U-10MF3E8	U-12MF3E8	U-14MF3E8	U-16MF3E8
		U-10MF3E8	U-12MF3E8	U-12MF3E8	U-12MF3E8	U-16MF3E8	U-16MF3E8	U-16MF3E8	U-16MF3E8
Power supply	Voltage	V	380-400-415	380-400-415	380-400-415	380-400-415	380-400-415	380-400-415	380-400-415
	Phase		Three phase	Three phase	Three phase	Three phase	Three phase	Three phase	Three phase
	Frequency	Hz	50	50	50	50	50	50	50
Cooling capacity	kW	50,0	56,0	61,5	68,0	73,0	78,5	85,0	90,0
EER ¹⁾	W/W	4,90	4,31	4,24	3,89	3,88	3,65	3,59	3,49
Current	A	16,80-16,00-15,40	21,00-20,00-19,20	23,70-22,50-21,70	28,30-26,90-25,90	31,00-29,50-28,40	35,10-33,40-32,20	39,60-37,60-36,20	42,60-40,50-39,00
Input power	kW	10,20	13,00	14,50	17,50	18,80	21,50	23,70	25,8
Heating capacity	kW	56,0	63,0	69,0	76,5	81,5	87,5	95,0	100,0
COP ¹⁾	W/W	5,23	4,77	4,79	4,47	4,50	4,31	4,19	4,17
Current	A	17,70-16,80-16,20	21,30-20,30-19,50	23,50-22,30-21,50	27,60-26,30-25,30	30,20-28,70-27,70	33,50-31,80-30,70	37,90-36,00-34,70	40,10-38,10-36,70
Input power	kW	10,70	13,20	14,40	17,10	18,10	20,30	22,70	24,00
Starting current	A	2,00	2,00	2,00	2,00	3,00	3,00	4,00	4,00
External static pressure (Max)	Pa	80	80	80	80	80	80	80	80
Air flow	m ³ /min	430	442	452	464	452	464	464	464
Sound pressure	Normal mode	dB(A)	59,0	61,0	62,0	63,0	63,5	64,5	65,0
	Silent mode 1 / 2	dB(A)	56,0/54,0	58,0/56,0	59,0/57,0	60,0/58,0	60,5/58,5	61,5/59,5	61,5/59,5
Sound power	Normal mode	dB(A)	81,5	84,0	84,5	86,0	84,5	86,0	86,0
Dimension	HxWxD	mm	1842 x 2360 (+60) x 1000	1842 x 2360 (+60) x 1000	1842 x 2360 (+60) x 1000	1842 x 2360 (+60) x 1000	1842 x 2360 (+60) x 1000	1842 x 2360 (+60) x 1000	1842 x 2360 (+60) x 1000
Net weight	kg	523	547	548	574	596	620	668	668
Piping diameter ²⁾	Liquid	Inch (mm)	5/8(15,88)/3/4(19,05)	5/8(15,88)/3/4(19,05)	5/8(15,88)/3/4(19,05)	5/8(15,88)/3/4(19,05)	3/4(19,05)/7/8(22,22)	3/4(19,05)/7/8(22,22)	3/4(19,05)/7/8(22,22)
	Discharge	Inch (mm)	7/8(22,22)/1(25,40)	7/8(22,22)/1(25,40)	1(25,40)/1-1/8(28,58)	1(25,40)/1-1/8(28,58)	1(25,40)/1-1/8(28,58)	1-1/8(28,58)/1-1/4(31,75)	1-1/8(28,58)/1-1/4(31,75)
	Suction	Inch (mm)	1-1/8(28,58)/1-1/4(31,75)	1-1/8(28,58)/1-1/4(31,75)	1-1/8(28,58)/1-1/4(31,75)	1-1/8(28,58)/1-1/4(31,75)	1-1/4(31,75)/1-1/2(38,10)	1-1/4(31,75)/1-1/2(38,10)	1-1/4(31,75)/1-1/2(38,10)
	Balance	Inch (mm)	1/4(6,35)	1/4(6,35)	1/4(6,35)	1/4(6,35)	1/4(6,35)	1/4(6,35)	1/4(6,35)
Refrigerant (R410A) / CO ₂ Eq.	kg / T	13,60/28,3968	15,10/31,5288	15,10/31,5288	16,60/34,6608	15,10/31,5288	16,60/34,6608	16,60/34,6608	16,60/34,6608
Maximum allowable indoor / outdoor capacity ratio	%	50 ~ 150	50 ~ 150	50 ~ 150	50 ~ 150	50 ~ 150	50 ~ 150	50 ~ 150	50 ~ 150
Operating range	Cool Min - Max	°C	-10 ~ +52	-10 ~ +52	-10 ~ +52	-10 ~ +52	-10 ~ +52	-10 ~ +52	-10 ~ +52
	Heat Min - Max	°C	-20 ~ +18	-20 ~ +18	-20 ~ +18	-20 ~ +18	-20 ~ +18	-20 ~ +18	-20 ~ +18
	Simultaneous op.	°C	-10 ~ +24	-10 ~ +24	-10 ~ +24	-10 ~ +24	-10 ~ +24	-10 ~ +24	-10 ~ +24

HP		34 HP	36 HP	38 HP	40 HP	42 HP	44 HP	46 HP	48 HP
Outdoor unit		U-8MF3E8	U-8MF3E8	U-10MF3E8	U-8MF3E8	U-10MF3E8	U-12MF3E8	U-14MF3E8	U-16MF3E8
		U-10MF3E8	U-12MF3E8	U-12MF3E8	U-16MF3E8	U-16MF3E8	U-16MF3E8	U-16MF3E8	U-16MF3E8
Power supply	Voltage	V	380-400-415	380-400-415	380-400-415	380-400-415	380-400-415	380-400-415	380-400-415
	Phase		Three phase	Three phase	Three phase	Three phase	Three phase	Three phase	Three phase
	Frequency	Hz	50	50	50	50	50	50	50
Cooling capacity	kW	96,0	101,0	107,0	113,0	118,0	124,0	130,0	135,0
EER ¹⁾	W/W	4,10	3,90	3,88	3,72	3,72	3,58	3,55	3,49
Current	A	38,60-36,70-35,40	42,30-40,20-38,70	45,60-43,30-41,70	50,20-47,70-46,00	52,40-49,70-47,90	56,50-53,70-51,80	61,10-58,10-56,00	63,90-60,70-58,50
Input power	kW	23,40	25,90	27,60	30,40	31,70	34,60	36,60	38,70
Heating capacity	kW	108,0	113,0	119,0	127,0	132,0	138,0	145,0	150,0
COP ¹⁾	W/W	4,64	4,48	4,51	4,31	4,36	4,25	4,18	4,17
Current	A	38,90-37,00-35,60	41,60-39,50-38,10	43,60-41,40-39,90	49,30-46,80-45,10	50,60-48,10-46,30	53,70-51,00-49,10	57,90-55,00-53,00	60,10-57,10-55,00
Input power	kW	23,30	25,20	26,40	29,50	30,30	32,50	34,70	36,00
Starting current	A	4,00	4,00	4,00	5,00	5,00	5,00	6,00	6,00
External static pressure (Max)	Pa	80	80	80	80	80	80	80	80
Air flow	m ³ /min	662	674	684	674	684	696	696	696
Sound pressure	Normal mode	dB(A)	64,0	64,5	65,0	65,5	66,0	66,5	67,0
	Silent mode 1 / 2	dB(A)	61,0/59,0	61,5/59,5	62,0/60,0	62,5/60,5	63,0/61,0	63,5/61,5	63,5/61,5
Sound power	Normal mode	dB(A)	84,5	85,5	85,5	85,5	86,0	86,5	87,0
Dimension	HxWxD	mm	1842 x 3540 (+120) x 1000	1842 x 3540 (+120) x 1000	1842 x 3540 (+120) x 1000	1842 x 3540 (+120) x 1000	1842 x 3540 (+120) x 1000	1842 x 3540 (+120) x 1000	1842 x 3540 (+120) x 1000
Net weight	kg	857	881	882	929	930	954	1002	1002
Piping diameter ²⁾	Liquid	Inch (mm)	3/4(19,05)/7/8(22,22)	3/4(19,05)/7/8(22,22)	3/4(19,05)/7/8(22,22)	3/4(19,05)/7/8(22,22)	3/4(19,05)/7/8(22,22)	3/4(19,05)/7/8(22,22)	3/4(19,05)/7/8(22,22)
	Discharge	Inch (mm)	1-1/8(28,58)/1-1/4(31,75)	1-1/8(28,58)/1-1/4(31,75)	1-1/4(31,75)/1-1/2(38,10)	1-1/4(31,75)/1-1/2(38,10)	1-1/4(31,75)/1-1/2(38,10)	1-1/4(31,75)/1-1/2(38,10)	1-1/4(31,75)/1-1/2(38,10)
	Suction	Inch (mm)	1-1/4(31,75)/1-1/2(38,10)	1-1/2(38,10)/1-5/8(41,28)	1-1/2(38,10)/1-5/8(41,28)	1-1/2(38,10)/1-5/8(41,28)	1-1/2(38,10)/1-5/8(41,28)	1-1/2(38,10)/1-5/8(41,28)	1-1/2(38,10)/1-5/8(41,28)
	Balance	Inch (mm)	1/4(6,35)	1/4(6,35)	1/4(6,35)	1/4(6,35)	1/4(6,35)	1/4(6,35)	1/4(6,35)
Refrigerant (R410A) / CO ₂ Eq.	kg / T	21,90/45,72719	23,40/48,85919	23,40/48,85919	23,40/48,85919	23,40/48,85919	24,90/46,3536	24,90/51,9912	24,90/51,9912
Maximum allowable indoor / outdoor capacity ratio	%	50 ~ 150	50 ~ 150	50 ~ 150	50 ~ 150	50 ~ 150	50 ~ 150	50 ~ 150	50 ~ 150
Operating range	Cool Min - Max	°C	-10 ~ +52	-10 ~ +52	-10 ~ +52	-10 ~ +52	-10 ~ +52	-10 ~ +52	-10 ~ +52
	Heat Min - Max	°C	-20 ~ +18	-20 ~ +18	-20 ~ +18	-20 ~ +18	-20 ~ +18	-20 ~ +18	-20 ~ +18
	Simultaneous op.	°C	-10 ~ +24	-10 ~ +24	-10 ~ +24	-10 ~ +24	-10 ~ +24	-10 ~ +24	-10 ~ +24

1) EER and COP calculation is based in accordance to EN14511. 2) Piping diameter under 90 m for ultimate indoor unit / over 90 m for ultimate indoor unit (if the longest piping equivalent length exceeds 90 m, increase the sizes of the main tubes by 1 rank for gas tubes and liquid tubes).

ECO G, the gas driven VRF

ECO G

The advanced Gas Driven VRF system offers increased efficiency and performance across the range. Improvements include increased part load performance, reduced gas consumption with a Miller-cycle engine and reduced electrical consumption by using DC-Fan motors.



2-Pipe ECO G GE3 Series.

Designed for better energy efficiency.



3-Pipe ECO G GF3 Series.

Domestic hot water can be supplied by effectively using waste heat generated during heating and cooling operation.



1 Limited electric supply

Electric consumption of ECO G is only 9% compared to ECOi because gas engine is utilized for the compressor driving force.

2 High demand of DHW with heating and cooling cogeneration

DHW is produced effectively thanks to heat from engine exhaust during heating and cooling.

3 Open and flexible design

ECO G system is designed to connect various Indoor units and controllers which are available for ECOi systems. With GE3 series, Pump Down system has been implemented to answer commercial needs.

4 Quick start up in heating at low ambient temperature

Gas heat pump systems make your building comfortably warm with a quick start by using waste heat from engine. Heating mode works from an ambient temperature of -21 °C.

Comparison of heating capacity.

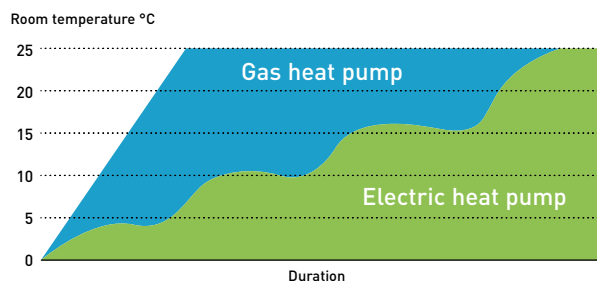

GE3/GF3 connectable indoor units

Type	Model number reference	2-Pipe ECO G GE3 Series	3-Pipe ECO G GF3 Series
Standard A2A indoor units	—	Yes ¹⁾	Yes ¹⁾
Water heat exchanger	PAW-250/500W(P)5G	Yes ²⁾	No
High static pressure hide-away	S-ME2E5	Yes	No
Heat recovery with DX coil - ZDX Series	PAW-ZDX3N	Yes	Yes
Air curtain with DX coil	PAW-EAIRC-HS/LS	Yes	Yes ³⁾
AHU connection kit	PAW-MAH3M	Yes	Yes ³⁾

1) Except for 1,5 kW capacity. 2) Allowed 1:1 and also mixed. If mixed, not operate at the same time WHE + DX only operate separately. 3) Smaller capacity than 16 kW only.

ECO G, the gas driven VRF

ECO G satisfies special requirements for your application and offers an environmentally friendly solution with Panasonic professional technology, providing reliable quality given its long development history, since 1985.

Our ECO G VRF range of commercial systems is leading the industry in the development of efficient and flexible systems.

200.000

GHP outdoor units sold all over the world



1985

Introduces first GHP (Gas Heat Pump) VRF air conditioner.

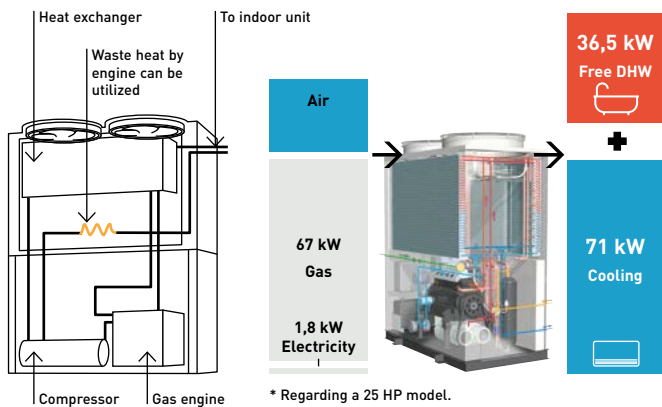

What is GHP? The Gas Heat Pump (GHP)

Panasonic Gas Heat Pump is a direct expansion system, with a compressor the same as the VRF system. A Gas engine is used as the driving force of the compressor instead of an electric motor. This gas engine compressor drive has 2 advantages:

- 1 | Waste heat available from the gas engine.
- 2 | No need for motor power consumption thanks to gas engine.

GHP is the natural choice for commercial projects, especially for those projects where electrical power restrictions apply.

Power supply problems?

If you are short of electric power, our ECO G is a perfect solution.

- Runs on natural gas or LPG and just needs single phase supply
- Enables the building's electrical power supply to be used for other critical electrical demands
- Reduces capital cost to upgrade power substations to run heating and cooling systems
- Reduces power loadings within a building especially during peak periods
- Electricity supply freed up for other uses such as IT servers, commercial refrigeration, manufacturing, lighting, etc...

Limited electricity area.

Comparison of electrical consumption on a 71 kW outdoor unit.

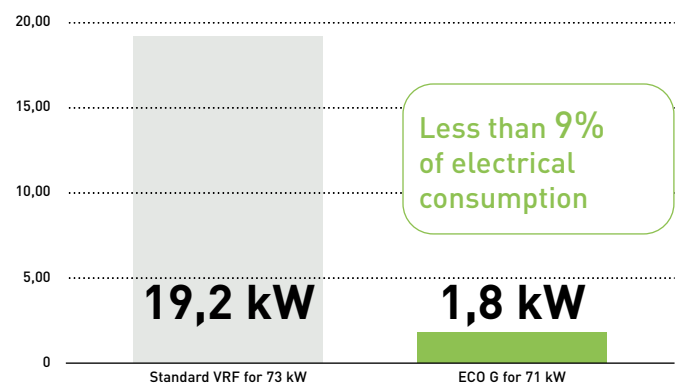

Application example: Hotel.

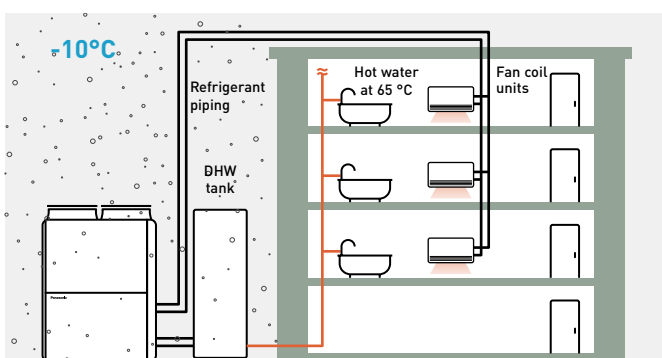

No need additional electric heaters. * This scheme is also valid with WHE.

High demand of domestic hot water in heating and cooling

The rejected heat from the engine is available for DHW production and can supply up to 46 kW of hot water at 65 °C. DHW at 65 °C is also ready to use in heating without additional electric heaters.

Quick start up and great heating capacity at low ambient temperature.

Waste heat from gas engine is utilized to raise temperature faster than electric VRF systems. This contributes great heating capacity at extremely low ambient temperature.

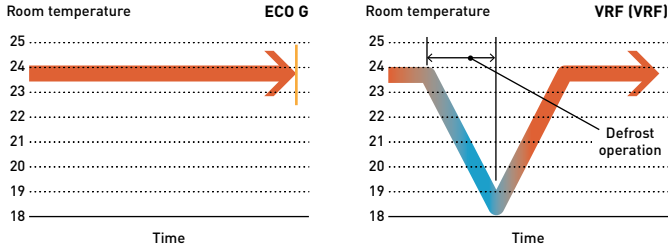

Lowest nitrogen oxide emissions.

The ECO G VRF systems have low nitrogen oxide emissions. In a pioneering development, the Panasonic ECO G features a brand lean-burn combustion system that utilizes air fuel ratio feedback control to reduce NOx emissions to an all time low.

Water chiller option.

Our ECO G system is also available with a water heat exchanger option, which can be combined with individual outdoor units or as part of a DX chilled water mix of indoor units. The system can be operated via a BMS system or a Panasonic supplied control panel, with chilled water set points from -15 °C ~ +15 °C and heating set points 35 °C ~ +55 °C.

Application

Application	Condition	ECO G
Hotel	High DHW demand	✓ Energy recovery of ECO G system can fulfill different requirement
Hotel	Needs to warm up swimming pool	✓
Office	Quick start up is necessary	✓ Speed of start up is quicker than VRF system
Winery	1) Outlet water demand at specific temperature 2) Needs high amount of power temporary (not every month)	✓ 1) Chiller application with hydro module (ECO G + WHE) can make this special process 2) Running cost can be saved since fixed Gas tariff per month is cheaper than fixed electric tariff.
Any building	In a city with power restriction	✓ - No need an additional power transformer - Space and cost can be saved
	At extremely low ambient condition	✓ Heating capacity is kept up to -20 °C without defrost process

Project case studies



Savills HQ Dublin and Google Block R. Ireland.
ECO G 3-Pipe units with a 243 kW load.
The project has been such a success that it has recently been awarded a Panasonic PRO Award for Best Contribution of efficient projects within Europe.



Thomas Cook's Sunprime Atlantic View resort.
A holiday resort in the Canaries. Spain.
229 rooms plus full spa and swimming pool facility.



CAPITA call centre. UK.
11 ECO G 3-Pipe units.
Over 150 indoor units in meeting rooms and open-plan areas.
Intelligent touch screen controller, the CZ-256ESMC2.



French winery Gennevilliers, France.
ECO G 3-Pipe units. One of the best solution utilized our ECO G solution for wine production process.

ECO G 3 Series

Introducing ECO G 3 Series. Optimised energy saving with reliable Panasonic technologies.

Improvement in blast efficiency

3-blades fan.

Propeller shape with 3 blades is more efficient
Max. 30% of fan electrical consumption is saved compared to conventional fan.

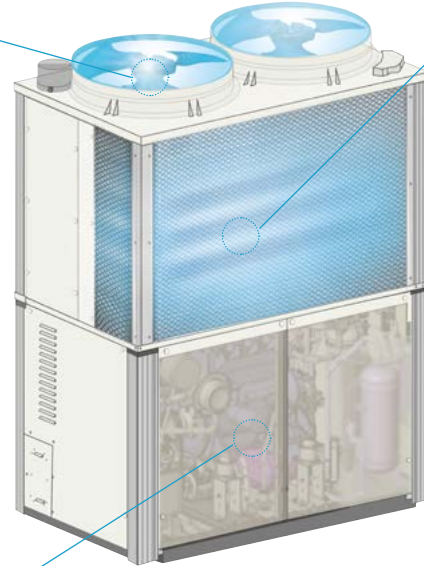
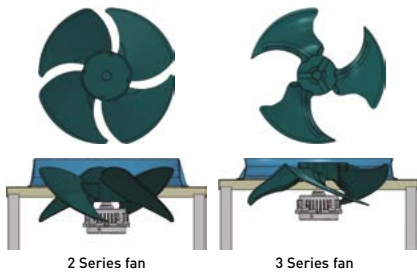

"L" type heat exchanger

Heat exchanger surface area is increased by 25% compared to previous model to optimise efficiency.

Heat exchanger surface area 25% up

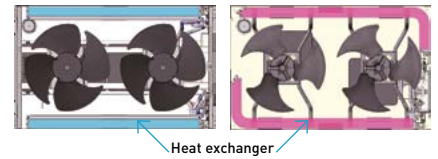

Better partial load control

Start / stop loss reduced by expanding the area where continuous operation is possible. Annual operation efficiency has further improved due to better efficiency at lower partial load.

Compressor.

- Amount of internal leakage is reduced due to reduction of clearances, the compressor efficiency in low load and low rotation region has been greatly improved. Moreover, efficiency of high speed and high load is also improved due to expansion of suction path resulting in reduction of suction pressure
- Optimise compressor capacity

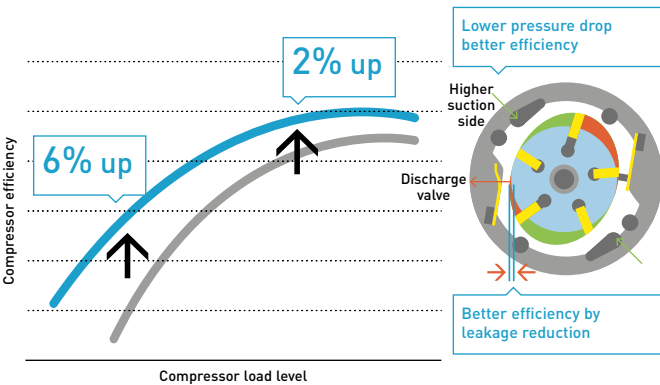

Engine.

- Continuous operation area widened at lower partial load by expanding operation area of lower speed
- Engine efficiency has improved by shifting output points to higher torque side

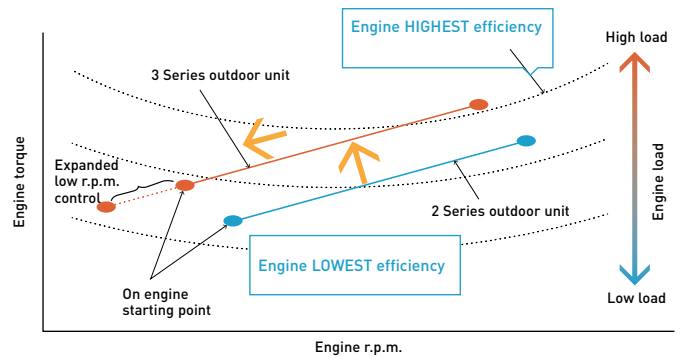

Engine pulley.

- Larger diameter engine pulley contributes to optimisation of compressor rotation speed ratio. Increased engine pulley diameter provides better performance at partial load, reducing ON / OFF operation.

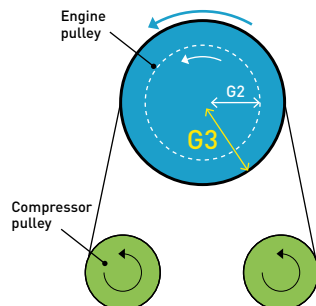

Line up of GE3 2-Pipe W-Multi.

- For new or renewal
- Available for water heat exchanger
- Maximum 60 HP combination



The highest seasonal performance in all capacity ranges.

High power efficiency of W-Multi system.

ECO G 3 Series system offers seasonal efficiency which has been drastically improved with the heat exchanger design, blast efficiency, partial load control.

Compared to previous model ECO G 2 Series.

All models have maximum 25% of SEER, 15% of SCOP improvement compared to previous model.

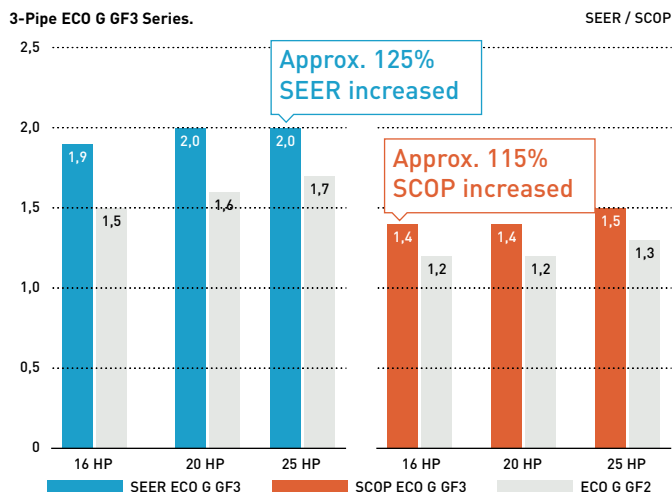
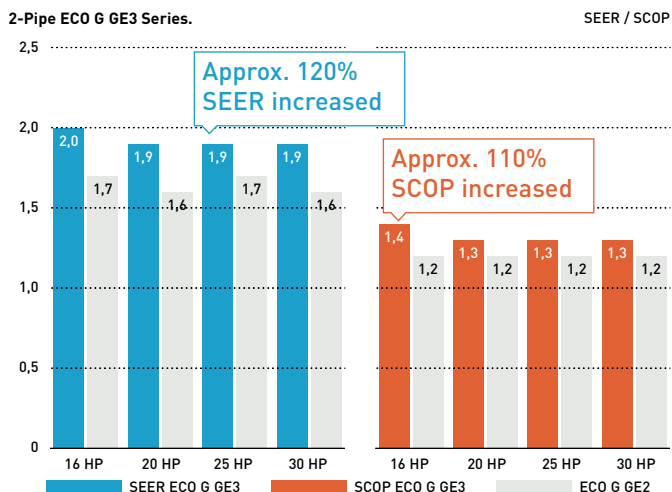

* Comparison under Panasonic condition follows EN14825.

Heating design operation conditions (GE3)

Operating range in heating has been expanded up to 24 °C (WB) for air to water use, to meet the demand of swimming pool applications.

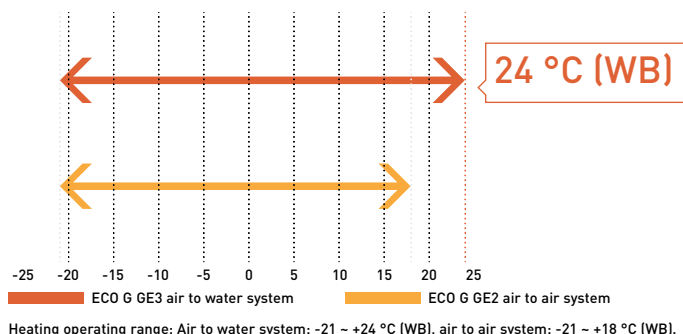

DHW priority mode setting in heating (GE3)

Ambient temperature range for DHW production is expandable by setting depending on DHW needs. Hot water at 65 °C is available in heating without additional electric heaters.

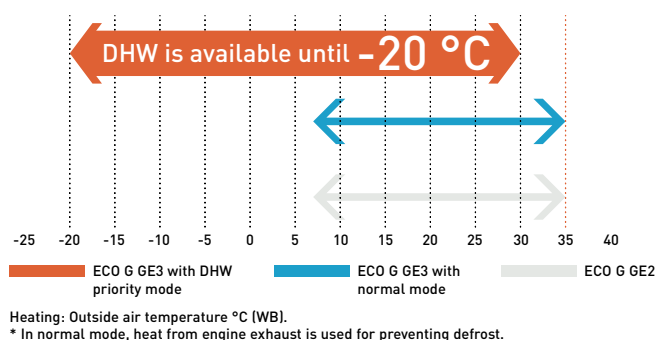

No defrost requirement (GE3 / GF3)

No defrost mode is selectable to get higher capacity at low ambient temperature.

Flexible design with wide line up of indoor units

The advanced GE3 Series can connect up to 64 indoor units.

Series	16 HP	20 HP	25 HP	30 HP	32 HP	36 HP	40 HP	45 HP	50 HP	55 HP	60 HP
2-Pipe ECO G GE3 Series	26	33	41	50	52	59	64	64	64	64	64
3-Pipe ECO G GF3 Series	24	24	24	—	—	—	—	—	—	—	—

2-Pipe ECO G GE3 Series

The GE3 Series has top level seasonal efficiency in this category. In addition, this product fits with special needs for commercial application thanks to DHW priority setting and auto Pump Down functions.



HP			16 HP	20 HP	25 HP	30 HP
Outdoor unit			U-16GE3E5	U-20GE3E5	U-25GE3E5	U-30GE3E5
Power supply	Voltage	V	220 - 230 - 240	220 - 230 - 240	220 - 230 - 240	220 - 230 - 240
	Phase		Single phase	Single phase	Single phase	Single phase
	Frequency	Hz	50	50	50	50
Cooling capacity		kW	45,0	56,0	71,0	85,0
Refrigeration load Pdesign ¹⁾		kW	45,0	56,0	71,0	85,0
$\eta_{s,c}$ (LOT21) ¹⁾			220,6%	219,3%	240,1%	229,3%
Input power		kW	1,17	1,12	1,80	1,80
Hot water in cooling mode (at 65 °C outlet)		kW	23,60	29,10	36,40	46,00
Max COP in hot water		W/W	1,55	1,55	1,49	1,47
Gas consumption cooling		kW	41,10	52,10	67,20	84,10
Heating capacity	Standard	kW	50,0	63,0	80,0	95,0
	Low temperature	kW	53,0	67,0	78,0	90,0
Refrigeration load Pdesign ¹⁾		kW	37,0	53,0	60,0	65,0
$\eta_{s,h}$ (LOT21) ¹⁾			150,6%	143,7%	146,9%	151,3%
Input power		kW	0,56	1,05	0,91	1,75
Gas consumption heating	Standard	kW	38,00	51,10	68,60	75,30
	Low temperature	kW	45,40	62,70	60,70	73,90
Starter amperes		A	30	30	30	30
External static pressure		Pa	10	10	10	10
Air flow		m ³ /min	370	420	460	460
Sound power	Normal	dB(A)	80	80	84	84
	Silent mode	dB(A)	77	77	81	81
Dimension	H x W x D	mm	2255 x 1650 x 1000	2255 x 1650 x 1000	2255 x 2026 x 1000	2255 x 2026 x 1000
Net weight		kg	765	765	870	880
Piping diameter	Liquid	Inch (mm)	1/2 (12,70)	5/8 (15,88)	5/8 (15,88)	3/4 (19,05)
	Gas	Inch (mm)	1-1/8 (28,58)	1-1/8 (28,58)	1-1/8 (28,58)	1-1/4 (31,75)
	Fuel gas	Inch (mm)	3/4 (19,05)	3/4 (19,05)	3/4 (19,05)	3/4 (19,05)
	Exhaust drain port	mm	25	25	25	25
	Hot water supply in/out		Rp3/4 (Nut, thread)	Rp3/4 (Nut, thread)	Rp3/4 (Nut, thread)	Rp3/4 (Nut, thread)
Elevation difference (in / out)			50	50	50	50
Refrigerant (R410A) / CO ₂ Eq.		kg / T	11,50/24,00	11,50/24,00	11,50/24,00	11,50/24,00
Maximum number of connectable indoor units			26	33	41	50
Operating range	Cool Min ~ Max	°C (DB)	-10 ~ +43	-10 ~ +43	-10 ~ +43	-10 ~ +43
	Heat Min ~ Max	°C (WB)	-21 ~ +18	-21 ~ +18	-21 ~ +18	-21 ~ +18

¹⁾ ErP test data.

Hot water take out function added, EU safety regulation standard cleared. 25 HP chassis enlarged due to specification improvement. Pre-coat corrosion fin. Auto Pump Down function.

Technical focus

- Superior seasonal energy efficiency, maximum 240,1%
- DHW priority setting
- Operating range in heating down to -21 °C and up to +24 °C for air to water system
- No defrost cycle

- Capacity ratio 50 ~ 200% ¹⁾
- Option of DX or chilled water for indoor heat exchange
- Maximum total piping length: 780 m

¹⁾ 50 ~ 200% only when one outdoor unit is installed. In other cases 50 ~ 130%.

2-Pipe ECO G GE3 Series combination from 32 to 60 HP

The GE3 Series has top level seasonal efficiency in this category. In addition, this product fits with special needs for commercial application thanks to DHW priority setting and Auto Pump Down functions.



HP			32 HP	36 HP	40 HP	45 HP	50 HP	55 HP	60 HP
Outdoor unit			U-16GE3E5	U-16GE3E5	U-20GE3E5	U-20GE3E5	U-25GE3E5	U-25GE3E5	U-30GE3E5
			U-16GE3E5	U-20GE3E5	U-20GE3E5	U-25GE3E5	U-25GE3E5	U-30GE3E5	U-30GE3E5
Power supply	Voltage	V	220-230-240	220-230-240	220-230-240	220-230-240	220-230-240	220-230-240	220-230-240
	Phase		Single phase	Single phase	Single phase	Single phase	Single phase	Single phase	Single phase
	Frequency	Hz	50	50	50	50	50	50	50
Cooling capacity		kW	90,0	101,0	112,0	127,0	142,0	156,0	170,0
Input power		kW	2,34	2,29	2,24	2,92	3,60	3,60	3,60
Hot water in cooling mode (at 65 °C outlet)		kW	47,20	52,70	58,20	65,50	72,80	82,40	92,00
Max COP in hot water		W/W	1,55	1,55	1,55	1,52	1,49	1,48	1,47
Gas consumption cooling		kW	82,20	93,20	104,20	119,30	134,40	151,30	168,20
Heating capacity	Standard	kW	100,0	113,0	126,0	143,0	160,0	175,0	190,0
	Low temperature	kW	106,0	120,0	134,0	145,0	156,0	168,0	180,0
Input power		kW	1,12	1,61	2,10	1,96	1,82	2,66	3,50
Gas consumption heating	Standard	kW	76,00	89,10	102,20	119,70	137,20	143,90	150,60
	Low temperature	kW	90,80	108,10	125,40	123,40	121,40	134,60	147,80
Starter amperes		A	30	30	30	30	30	30	30
External static pressure		Pa	10	10	10	10	10	10	10
Air flow		m ³ /min	370/370	370/420	420/420	420/460	460/460	460/460	460/460
Sound power	Normal	dB(A)	83	83	83	86	87	87	87
	Silent mode	dB(A)	80	80	80	83	84	84	84
Dimension	Height	mm	2255	2255	2255	2255	2255	2255	2255
	Width	mm	1650+100 +1650	1650+100 +1650	1650+100 +1650	1650+100 +2026	2026+100 +2026	2026+100 +2026	2026+100 +2026
	Depth	mm	1000	1000	1000	1000	1000	1000	1000
Net weight		kg	1530(765+765)	1530(765+765)	1530(765+765)	1635(765+870)	1740(870+870)	1750(870+880)	1760(880+880)
	Liquid	Inch (mm)	3/4(19,05)	3/4(19,05)	3/4(19,05)	3/4(19,05)	3/4(19,05)	7/8(22,22)	7/8(22,22)
Piping diameter	Gas	Inch (mm)	1-1/4(31,75)	1-1/4(31,75)	1-1/2(38,10)	1-1/2(38,10)	1-1/2(38,10)	1-1/2(38,10)	1-1/2(38,10)
	Fuel gas	Inch (mm)	3/4(19,05)	3/4(19,05)	3/4(19,05)	3/4(19,05)	3/4(19,05)	3/4(19,05)	3/4(19,05)
	Exhaust drain port	mm	25	25	25	25	25	25	25
	Hot water supply in/out		Rp3/4 (Nut, thread)	Rp3/4 (Nut, thread)	Rp3/4 (Nut, thread)	Rp3/4 (Nut, thread)	Rp3/4 (Nut, thread)	Rp3/4 (Nut, thread)	Rp3/4 (Nut, thread)
Elevation difference (in / out)		50	50	50	50	50	50	50	
Refrigerant (R410A) / CO ₂ Eq.		kg / T	2x11,50/24,00	2x11,50/24,00	2x11,50/24,00	2x11,50/24,00	2x11,50/24,00	2x11,50/24,00	2x11,50/24,00
Maximum number of connectable indoor units			52	59	64	64	64	64	64
Operating range	Cool Min ~ Max	°C	-10 ~ +43	-10 ~ +43	-10 ~ +43	-10 ~ +43	-10 ~ +43	-10 ~ +43	-10 ~ +43
	Heat Min ~ Max	°C	-21 ~ +18	-21 ~ +18	-21 ~ +18	-21 ~ +18	-21 ~ +18	-21 ~ +18	-21 ~ +18

Data is for reference. Hot water take out function added, EU safety regulation standard cleared. 25 HP chassis enlarged due to specification improvement. Pre-coat corrosion fin. Auto Pump Down function.

Technical focus

- Maximum 60 HP combination
- Superior seasonal energy efficiency, maximum 240,1%
- DHW priority setting
- Operating range in heating down to -21 °C and up to +24 °C for air to water system
- No defrost cycle
- Option of DX or chilled water for indoor heat exchange
- Maximum total piping length: 780 m



3-Pipe ECO G GF3 Series

Excellent performance and free domestic hot water

Panasonic 3-Pipe Multi system is capable of simultaneous heating / cooling and individual operation of each indoor unit by only one outdoor unit. As a result, efficient individual air conditioning is possible in buildings having diverse room temperatures. In addition, domestic hot water is created for free in cooling mode, without additional boilers or electric heaters.

System example.

Improved maintenance intervals. The unit only needs to be serviced every 10000 hours.

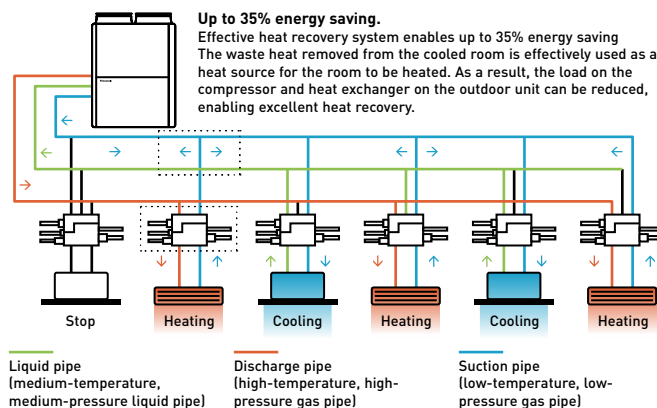

3-Pipe control solenoid valve kit.

KIT-P56HR3
(CZ-P56HR3 + CZ-CAPE2).
CZ-P56HR3
Up to 5,6 kW.

KIT-P160HR3
(CZ-P160HR3 + CZ-CAPE2).
CZ-P160HR3
Up to 16,0 kW.

3-Pipe control PCB.
CZ-CAPE2*

* For Wall-mounted. Must be added to the CZ-P56HR3 or CZ-P160HR3.

Solenoid valve kit

To be installed on all 'zones', allowing simultaneous heating and cooling. Up to 24 indoor units are capable of simultaneous heating / cooling operation. Oil-recovery operation gives more stable comfort air-conditioning control.

Power supply problems?

If you are short of electrical power, our gas heat pump could be the perfect solution:

- Runs on natural gas or LPG and needs just a single phase supply
- Enables the building's electrical power supply to be used for other critical electrical demands
- Reduces capital cost to upgrade power substations to run heating and cooling systems

- Reduces power loadings within a building especially during peak periods
- Electricity supply freed up for other uses such as IT servers, commercial refrigeration, manufacturing, lighting etc.

ECO G outdoor heat exchanger.

- Integrated DX and hot water coil
- No defrost required
- Faster reaction to demand for heating

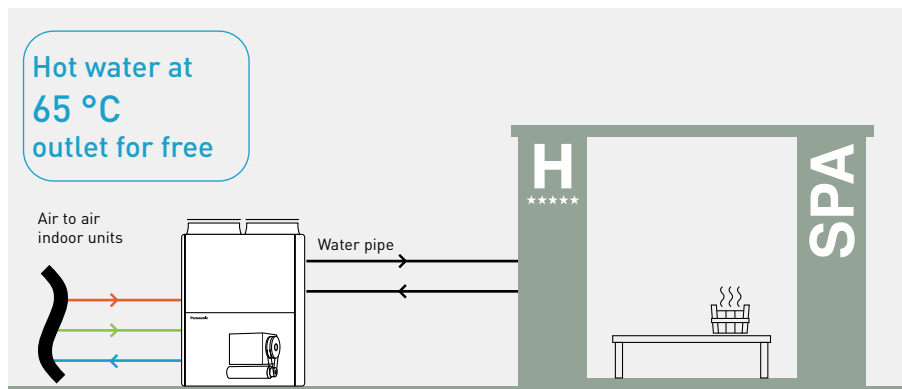
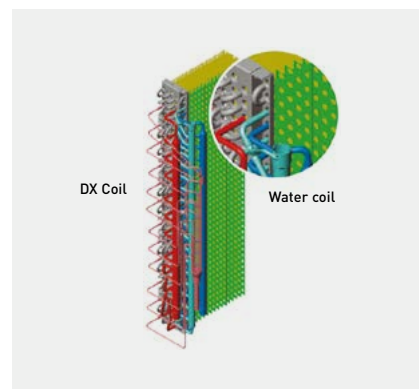

DHW production in heating and cooling

Free DHW is available 365 days a year. Hot water is produced effectively from waste heat from the engine. Perfect solution for hotel projects requiring high demand for hot water.

HP	Free DHW (in cooling mode)
16 HP	23,6 kW
20 HP	27,1 kW
25 HP	40,5 kW

3-Pipe ECO G GF3 Series

DHW available in all seasons.

Effective production of domestic hot water from engine waste heat in both heating and cooling, all year round.



HP			16 HP	20 HP	25 HP
Outdoor unit			U-16GF3E5	U-20GF3E5	U-25GF3E5
Power supply	Voltage	V	220 - 230 - 240	220 - 230 - 240	220 - 230 - 240
	Phase		Single phase	Single phase	Single phase
	Frequency	Hz	50	50	50
Cooling capacity		kW	45,0	56,0	71,0
Refrigeration load Pdesign ¹⁾		kW	45,0	56,0	71,0
$\eta_{s,c}$ (LOT21) ¹⁾			185,2%	198,8%	204,9%
Input power		kW	1,17	1,40	1,80
Hot water in cooling mode (at 65 °C outlet)		kW	23,60	27,10	40,50
Gas consumption cooling		kW	45,80	54,80	73,70
Heating capacity	Standard	kW	50,0	63,0	80,0
	Low temperature	kW	53,0	67,0	78,0
Refrigeration load Pdesign ¹⁾		kW	38,0	52,0	60,0
$\eta_{s,h}$ (LOT21) ¹⁾			139,2%	140,2%	150,9%
Input power		kW	0,56	1,05	0,91
Gas consumption heating	Standard	kW	42,20	51,10	68,60
Starter amperes		A	30	30	30
Air flow		m ³ /min	370	400	460
Sound power	Normal	dB(A)	80	81	84
	Silent mode	dB(A)	77	78	81
Dimension	H x W x D	mm	2255 x 1650 x 1000	2255 x 1650 x 1000	2255 x 2026 x 1000
Net weight		kg	775	775	880
Piping diameter	Liquid	Inch (mm)	3/4 (19,05)	3/4 (19,05)	3/4 (19,05)
	Gas	Inch (mm)	1 1/8 (28,58)	1 1/8 (28,58)	1 1/8 (28,58)
	Discharge	Inch (mm)	7/8 (22,22)	1 (25,40)	1 (25,40)
	Fuel gas	Inch (mm)	3/4 (19,05)	3/4 (19,05)	3/4 (19,05)
	Exhaust drain port	mm	25	25	25
Hot water supply in/out		Rp ³ / ₄ (Nut, thread)	Rp ³ / ₄ (Nut, thread)	Rp ³ / ₄ (Nut, thread)	
Elevation difference (in / out)		m	50	50	50
Refrigerant (R410A) / CO ₂ Eq.		kg / T	11,50 / 24,00	11,50 / 24,00	11,50 / 24,00
Maximum number of connectable indoor units			24	24	24
Operating range	Cool Min ~ Max	°C	-10 ~ +43	-10 ~ +43	-10 ~ +43
	Heat Min ~ Max	°C	-21 ~ +18	-21 ~ +18	-21 ~ +18

1) ErP test data.

Hot water take out function added, EU safety regulation standard cleared. 25 HP chassis enlarged due to specification improvement. Pre-coat corrosion fin. Auto Pump Down function.

Solenoid valve kit

KIT-P56HR3	3-Pipe control solenoid valve kit (up to 5,6 kW)
CZ-P56HR3	Solenoid valve kit (up to 5,6 kW)
CZ-CAPE2	3-Pipe control PCB
KIT-P160HR3	3-Pipe control solenoid valve kit (from 5,6 to 16,0 kW)
CZ-P160HR3	Solenoid valve kit (from 5,6 kW to 16,0 kW)
CZ-CAPE2	3-Pipe control PCB
CZ-CAPEK2 ²⁾	3-Pipe control PCB for wall-mounted

3-Pipe control box kit

CZ-P456HR3	4 ports 3 pipe box (up to 5,6 kW per port)
CZ-P656HR3	6 ports 3 pipe box (up to 5,6 kW per port)
CZ-P856HR3	8 ports 3 pipe box (up to 5,6 kW per port)
CZ-P4160HR3	4 ports 3 pipe box (up to 16,0 kW per port)

2) Available for S-45/56/73/106MK2E5B.

Outstanding seasonal energy efficiency, maximum 204,9%

- Capacity ratio 50 ~ 200%
- No defrost cycle
- Maximum total piping length: 780 m

Flexible installation

- Full heating capacity down to -21 °C (WB)
- DHW production for all the year
- Connection of up to 24 indoor units



Panasonic GHP/EHP Hybrid System. First intelligent technology

Taking advantage of Gas and Electricity to achieve better energy savings.

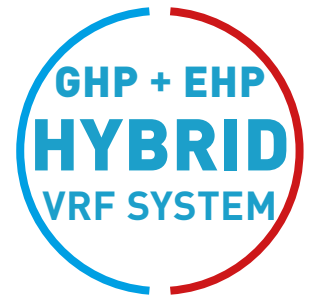

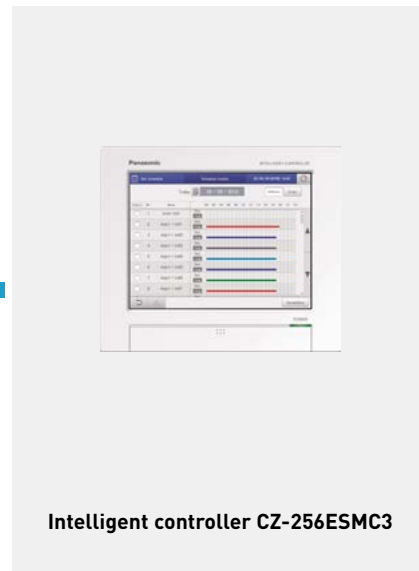
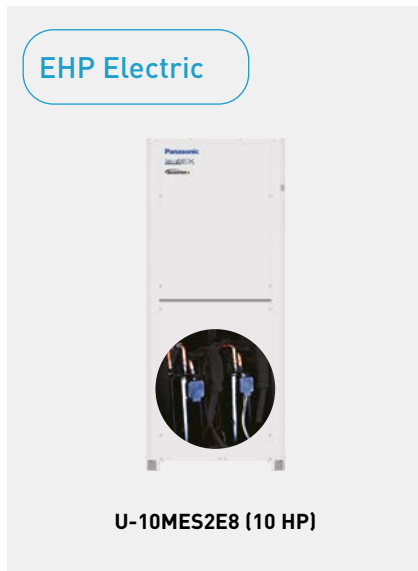
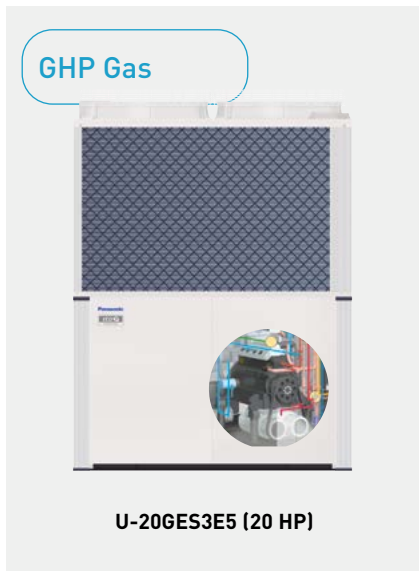

Master unit GHP

- Load calculation of GHP and EHP
- Operation in accordance with the upper limit setting
- Individual capacity control
- Device control
- Special control (Defrost, Oil recovery, 4 Way-valve matching / Abnormality processing)

Slave Unit EHP

Intelligent controller

- Demand monitoring
- Indoor / total load calculation
- Operation Ratio Indication
- upper limit setting of MAP according to:
 - Energy unit RRP
 - Electric power demand
 - Air conditioning load

Schematic of GHP/EHP Hybrid System.

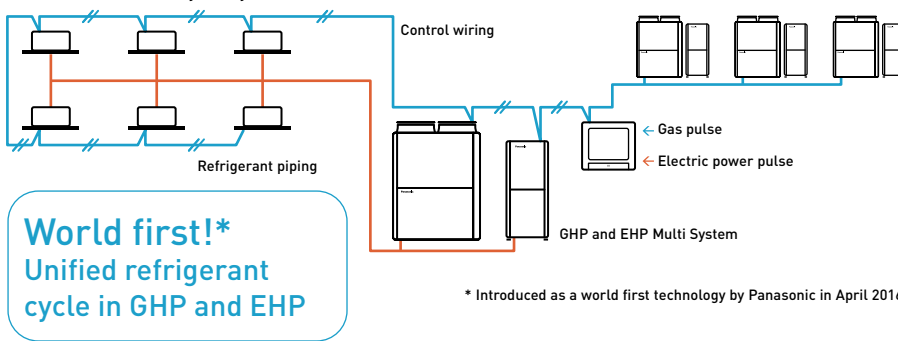

1 Peak cut of electricity consumption

Electrical peak demand is significantly reduced thanks to GHP system consuming less than 10% of electricity of EHP system.

* Image of Hotel project.

Electric power usage.

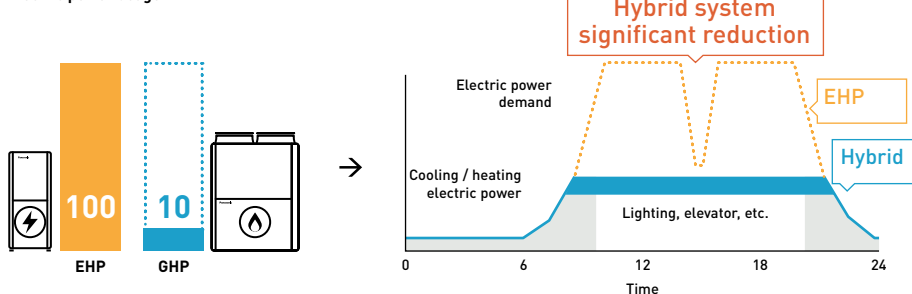

2 Optimal control to maximize energy saving

Switching the operation between GHP and EHP system on the basis of usage, energy demand, part load.

* Specification is tentative.

Optional control method.

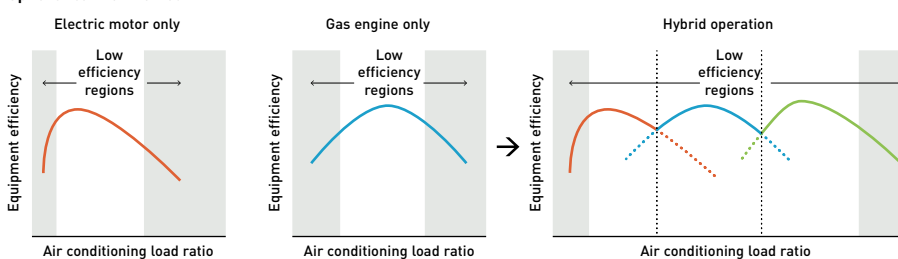

3 Free hot water production by GHP system

Hot water is effectively produced from waste heat of engine.

* Specification is tentative.

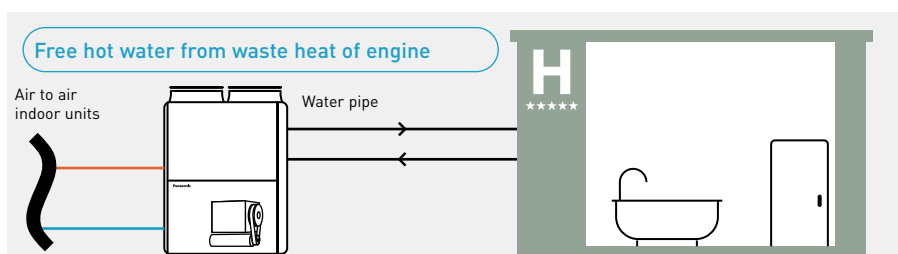

GHP/EHP Hybrid System

Panasonic's reliable ECO G / ECOi technology provides energy savings, utilising the advantages of both gas and electricity

The hybrid system can offer intelligent operation logic for better economy and efficiency by taking the best of ECO G. A heating and cooling system operating in a similar way to a hybrid car.

How to smartly operate a GHP and EHP system depending on your needs

4 different mode settings are available with the intelligent controller. Switch the operation between GHP and EHP or operating both units together to maximize the effect for different requirements such as economy and efficiency.

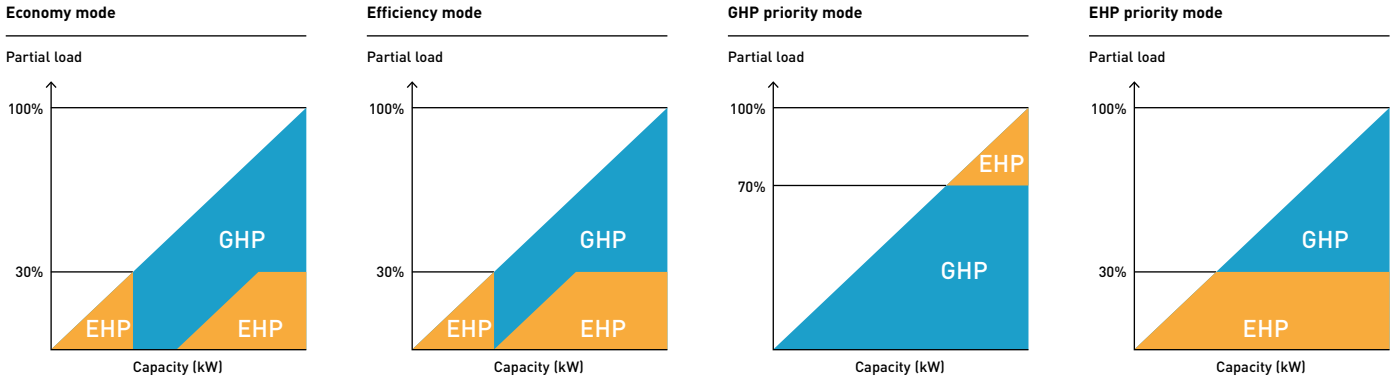

Optimal control example: Economy mode

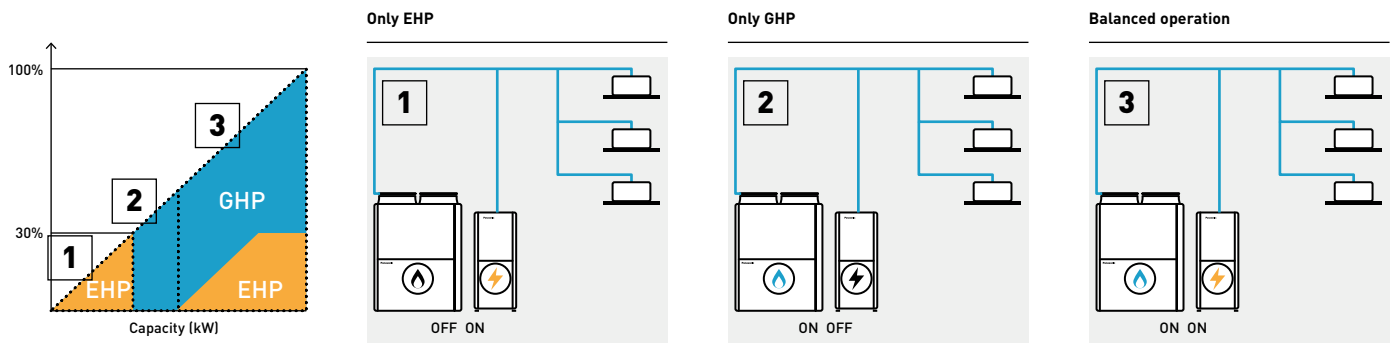

DHW priority mode in Hybrid + WHE System

When DHW is required during cooling operation by EHP, EHP is automatically turned "OFF" and GHP is turned "ON" to produce DHW for free.

High efficiency mode.

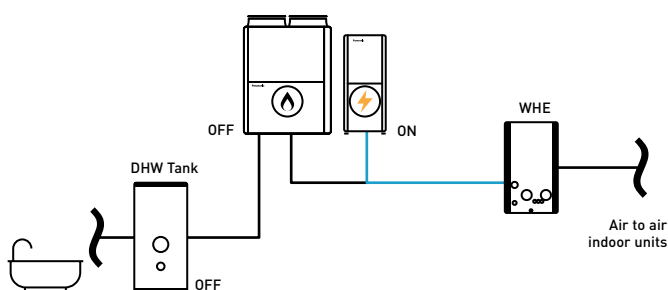

DHW priority mode.

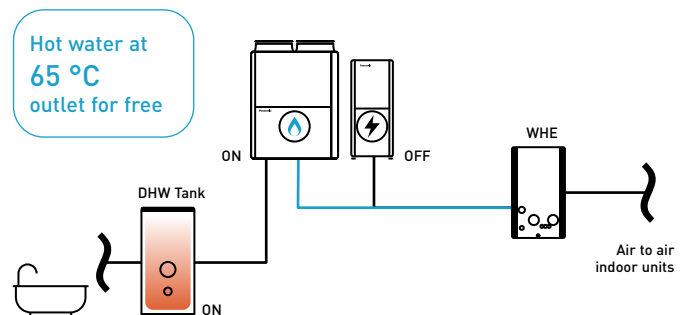

2-Pipe Hybrid GHP/EHP

- Extended lifespan with intelligent energy management.
The goal is for the EHP and GHP to work at optimal speeds
- Low energy cost
- Low emissions



			Hybrid GHP	Hybrid EHP
			20 HP	10 HP
Outdoor unit			U-20GES3E5	U-10MES2E8
Power supply	Voltage	V	220 - 230 - 240	380 - 400 - 415
	Phase		Single phase	Three phase
	Frequency	Hz	50	50
Cooling capacity		kW	56,0	28,0
$\eta_{s,c}$ (LOT21)			211,8%	275,4%
Current		A	5,18	10,70/10,20/9,80
Input power		kW	1,12	6,41
Hot water in cooling mode (at 65 °C outlet)		kW	26,20	—
Gas consumption cooling		kW	52,10	—
Heating capacity		kW	63,0	31,5
$\eta_{s,h}$ (LOT21)			143,2%	167,6%
Current		A	4,79	11,10/10,50/10,10
Input power		kW	1,05	6,62
Gas consumption heating	Standard	kW	51,10	—
Starting current		A	30	1
Air flow		m ³ /min	420	224
Sound pressure	Normal mode	dB(A)	58	56
Sound power	Normal mode	dB(A)	80	77
Dimension	HxWxD	mm	2255x1650x1000	1842x770x1000
Net weight		kg	765	210
Piping diameter ¹⁾	Liquid	Inch (mm)	5/8 (15,88)	3/8 (9,52)
	Gas	Inch (mm)	1 1/8 (28,58)	7/8 (22,22)
	Balance	Inch (mm)	1/4 (6,35)	1/4 (6,35)
Drain heater		W	40	—
Refrigerant (R410A) / CO ₂ Eq.		kg / T	11,05/23,0724	5,60/11,6928
Maximum allowable indoor / outdoor capacity ratio %			50 - 130	50 - 130
Operating range	Cool Min ~ Max	°C	-10 ~ +43	-10 ~ +43
	Heat Min ~ Max	°C	-21 ~ +18	-21 ~ +18

1) Please refer service manual when the maximum piping length exceeds 90 meters (equivalent length).

Technical focus

- 4 settings (economy, efficiency, GHP priority mode, EHP priority mode)
- DHW energy recovery 26,2 kW (at 65 °C) by engine waste heat
- Unified refrigerant cycle in GHP and EHP for easy installation
- DHW priority mode with WHE system
- Connection of up to 48 indoor units



Water heat exchanger for hydronic applications

Panasonic water heat exchanger available with ECOi (VRF) and ECO G (gas driven VRF) systems. Those are suitable not only for new projects but also for the old chiller systems to be replaced.



Chiller replacement. Chilled water supply to fan coils

Chiller replacement.

When some old chillers needed replacing at the end of their operational lifetime, ECO Gs with water heat exchangers enabled the project to be carried out in stages whilst still utilising the existing water pipe work and fan coils. This enabled the project to be delivered on time, to a restricted budget and avoided all issues regarding refrigerant in confined spaces.



Connection to 'close control' computer equipment.

Computer room applications.

When all available electrical power needed to be utilised for the IT equipment for a leading international bank, the cooling load of over 450 kW had to be powered by gas. The outdoor units were connected via water heat exchangers to cooling coils inside the 'close control' units thereby maintaining a conditioned environment for temperature and humidity. By utilising the hot water function over 100 kW of hot water are supplied to the building and therefore the additional benefit of considerable CO₂ savings is ensured.

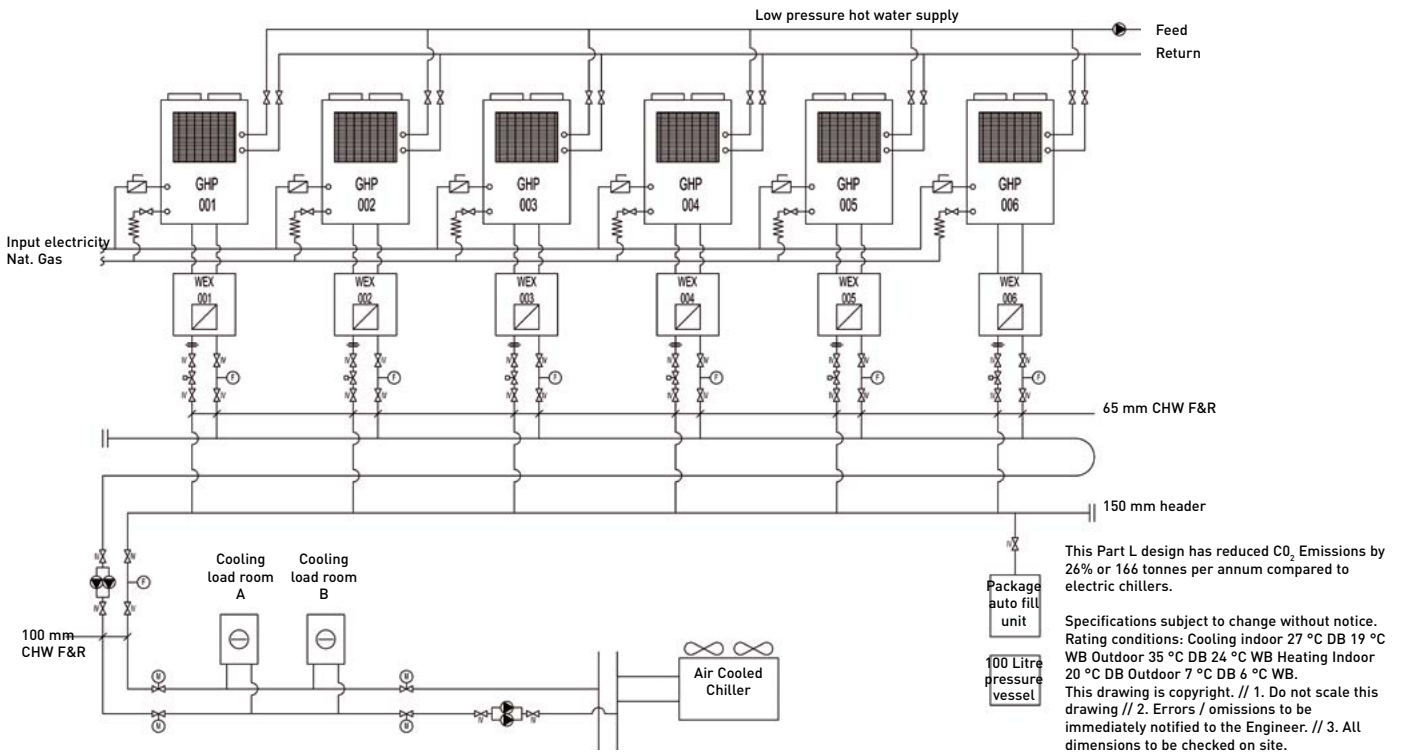

ECOi water heat exchanger

Electrical VRF with water heat exchanger
 · With this easy to install water heat exchanger unit, you can now cover projects up to 51 kW hot water demand or 44 kW on chilled application in an efficient and cost effective way

System example.

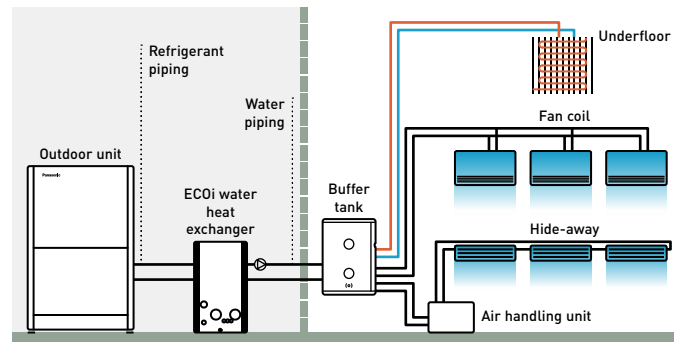

A buffer tank of minimum 280 l for 28 kW and 500 l for 50 kW is always needed.

Example of Hotel renewal of existing chiller and boiler system with Panasonic ECO G and Aquarea mixed solution

ECO G and Aquarea are the smart solution for renewal Chiller / Boiler applications with annual running cost savings around 13600€.

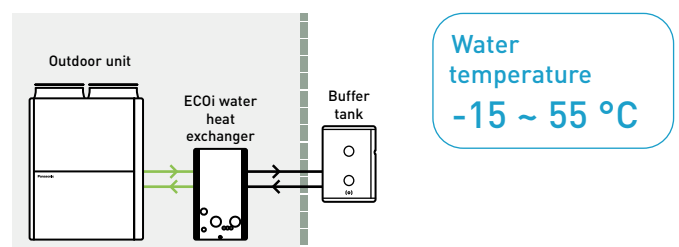

ECOi 2-Pipe with water heat exchanger for chilled and hot water production

Water heat exchanger (WHE) for hydronic applications.

WHE for ECOi systems controlled by a CZ-RTC5B timer remote control.

Energy-efficient capacity control with superior external static pressure is now ready.

Availability of easy vertical stacking allows installations in a limited space (up to 3 units)*.

Stainless steel plate heat exchanger with anti-freeze protection control.

Change over between heating and cooling operation.

* Stacking kit (PAW-3WSK) is necessary.

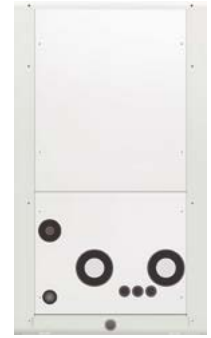

Hydrokit with A class water pump		PAW-250WP5G1	PAW-500WP5G1
Hydrokit without pump		PAW-250W5G1	PAW-500W5G1
Cooling capacity (A 35 °C, W 7 °C)	kW	25,0	50,0
Heating capacity	kW	28,0	56,0
Heating capacity (A +7 °C, W 45 °C)	kW	28,0	56,0
COP (A +7 °C, W 45 °C)	W/W	2,97	3,10
Energy efficiency class at 35 °C¹⁾		A++	A++
$\eta_{s,h}$ (LOT1) ²⁾		152,0%	152,0%
Dimension	HxWxD	mm	1000 x 575 x 1110
Net weight		kg	135 (140 with pump)
Water pipe connector			Rp2 Female thread (50A)
Heating water flow ($\Delta T=5$ K, 35 °C)	m ³ /h		5,16
Electric backup heater	kW		Not equipped
Flow switch			Equipped
Water filter			Equipped
Input power with A class water pump / without pump	kW		0,329 / 0,024
Maximum current with A class water pump / without pump	A		1,43 / 0,10
Outdoor unit		U-10ME2E8	U-20ME2E8
Sound pressure		dB(A)	56
Dimension	HxWxD	mm	1842 x 770 x 1000
Net weight		kg	210
Piping diameter	Liquid	Inch (mm)	3/8(9,52)
	Gas	Inch (mm)	7/8 (22,22)
Pipe length range / Pipe length for nominal capacity		m	170 / 7,5
Elevation difference (in / out)		m	50 (OU above) 35 (OU below)
Pre-charged pipe length / Additional gas amount (R410A)		m / g/m	0 < / Refer to manual
Refrigerant (R410A) / CO ₂ Eq.		kg	5,6 (need additional gas amount at site)
Operating range	Heat Min ~ Max	°C	-11 ~ +15 ³⁾
Water outlet temperature range	Cool Min ~ Max	°C	+5 ~ +15
	Heat Min ~ Max	°C	+35 ~ +45

1) Unit efficiency energy level: Scale from A+++ to D. 2) Seasonal space cooling / heating energy efficiency following COMMISSION REGULATION (EU) 813/2013. 3) With accessory low temperature kit -25 ~ +15 °C. Available only as a spare part.

Performance calculation in agreement with Eurovent. Sound pressure measured at 1 m from the outdoor unit and at 1,5 m height.

Accessories

PAW-3WSK Stacking kit for vertically stacking up to 3 WHE [4 pieces per Kit]

Stacking kit PAW-3WSK.

It is possible to stack up to 3 units. When stacking units, always anchor the bottom unit to the ground using the anchor holes.

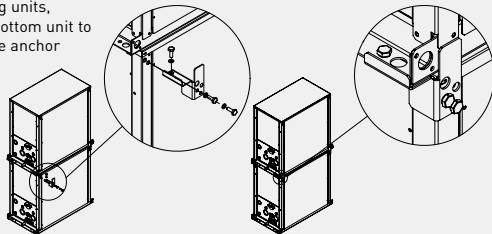

Technical focus

- Heating, cooling and DHW
- A class water pump included (only in P model)
- Flexible modularity from 25 kW
- Better partial load vs standard chiller system
- Compatible with all centralized controllers
- Maximum distance between outdoor unit and WHE: 170 m
- Maximum hot water outlet temperature: 45 °C
- Minimum chilled water outlet temperature: 5 °C
- Outdoor temperature range in heating mode: -11 °C to +15 °C (with low temperature kit -25 °C*)

* Available as a spare part.



ECO G with water heat exchanger for chilled and hot water production

Water heat exchanger (WHE) for hydronic applications.

WHE for ECO G system controlled by a timer remote control CZ-RTC5B.

Energy-efficient capacity control is now ready.

Availability of easy vertical stacking allows installations in a limited space (up to 3 units)*.

Stainless steel plate heat exchanger with anti-freeze protection control.

Change over between heating and cooling operation.

* Stacking kit (PAW-3WSK) is necessary.

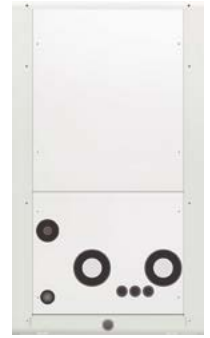

Hydrokit with A class water pump			PAW-500WP5G1	PAW-710WP5G1
Hydrokit without pump			PAW-500W5G1	PAW-710W5G1
Cooling capacity	kW		—	—
Cooling capacity [A +35 °C, outlet W 7 °C, inlet W 12 °C]	kW		50,0	67,0
EER [A +35 °C, outlet W 7 °C, inlet W 12 °C]	W/W		0,78	0,89
Heating capacity	kW		60,0	80,0
Heating capacity [A +7 °C, W 35 °C]	kW		60,9	81,2
COP [A +7 °C, W 35 °C]	W/W		1,15	1,18
Heating capacity [A +7 °C, W 45 °C]	kW		60,0	80,0
COP [A +7 °C, W 45 °C]	W/W		1,02	1,04
Heating capacity [A -7 °C, W 35 °C]	kW		48,2	50,8
COP [A -7 °C, W 35 °C]	W/W		0,80	0,80
Heating capacity [A -15 °C, W 35 °C]	kW		46,3	50,0
COP [A -15 °C, W 35 °C]	W/W		0,80	0,80
Refrigeration load Pdesign	kW		48,0	—
Energy efficiency class at 35 °C¹⁾			A+	—
η_{s,h} (LOT1)²⁾			130,0%	128,0%
Dimension	HxWxD	mm	1000 x 575 x 1110	1000 x 575 x 1110
Net weight		kg	155 (165 with pump)	160 (175 with pump)
Water pipe connector			Rp2 Female thread (50A)	Rp2 Female thread (50A)
Heating water flow [ΔT=5 K, 35 °C]	m ³ /h		10,32	13,76
Electric backup heater	kW		Not equipped	Not equipped
Flow switch			Equipped	Equipped
Water filter			Equipped	Equipped
Input power with A class water pump / without pump	kW		0,574 / 0,024	0,824 / 0,024
Maximum current with A class water pump / without pump	A		2,50 / 0,10	3,60 / 0,10
Outdoor unit			U-20GE3E5	U-30GE3E5
Sound power	Normal / Silent	dB(A)	80 / 77	84 / 81
Dimension	HxWxD	mm	2255 x 1650 x 1000	2255 x 2026 x 1000
Net weight		kg	765	880
Piping diameter	Liquid	Inch (mm)	5/8 (15,88)	3/4 (19,05)
	Gas	Inch (mm)	1-1/8 (28,58)	1-1/4 (31,75)
Pipe length range / Pipe length for nominal capacity		m	170 / 7	170 / 7
Elevation difference (in / out)		m	50 [OU above] 35 [OU below]	50 [OU above] 35 [OU below]
Refrigerant (R410A) / CO ₂ Eq.		kg / T	11,50 / 24,00	11,50 / 24,00
Operating range	Heat Min ~ Max	°C	-21 ~ +24 (until outlet temperature 45)	-21 ~ +24 (until outlet temperature 45)
Water outlet temperature range	Cool Min ~ Max	°C	-15 ~ +15	-15 ~ +15
	Heat Min ~ Max	°C	+35 ~ +55	+35 ~ +55

1) Unit efficiency energy level: Scale from A+++ to D. 2) ErP test data. Seasonal space cooling / heating energy efficiency following COMMISSION REGULATION (EU) 813/2013.

Performance calculation in agreement with Eurovent. Sound pressure measured at 1 m from the outdoor unit and at 1,5 m height.

Accessories

PAW-3WSK Stacking kit for vertically stacking up to 3 WHE [4 pieces per Kit]

Technical focus

- Heating, cooling and DHW
- A class water pump included (only in P model)
- Installation up to 80 kW
- Free DHW from waste heat of engine
- Compatible with all centralized controllers
- Maximum distance between outdoor unit and WHE: 170 m
- Hot water outlet temperatures from 35 °C to 55 °C
- Chilled water outlet temperatures from -15 °C to +15 °C
- Minimum outdoor temperature in heating mode: -21 °C



Leak detection and automatic Pump Down for R410A refrigerant

Pump Down Systems to detect refrigerant leaks, that offers complete assurance and safety protection. It's an ideal solution for hotels, offices and public buildings where the strict safety of end users and workers is required.



The system monitors refrigerant leakage continually and provides a warning, preventing major refrigerant loss and potential damage to the installation's efficiency. The system can reduce potential refrigerant loss by up to 90%.

As well as ensuring safe and reliable operation, Panasonic's Pump Down system contributes towards BREEAM POL1 points and enables compliance with current EN 378 standards, covering applications where refrigeration concentration levels exceed practical safety limits of 0,44 kg/m³.

Basic Pump Down function:

- Leak detection
- Activate Pump Down process
- Collect refrigerant within receiver tank
- Close valves to isolate refrigerant

Technical focus:

- Compatible with Mini ECOi / ECOi EX / ECO G* Series with R410A refrigerant
- A receiver kit included as standard
- Includes updated controller
- Connection in two ways:
 - 1 | With local room leakage sensors
 - 2 | Using innovative algorithm
- R22 renewal possible

* For connection to GHP, additional components required dependent on configuration. Please contact your local Panasonic representative for details.



The Pump Down systems are ideal for hotels, offices and public buildings where safety of building occupants is a must.

Direct leak detection method: the safest solution for small rooms

The leak detector is connected directly to the indoor unit and the Pump Down system is directly connected to the outdoor unit PCB. The Pump Down system will activate when a leak is detected in the room and initiate a refrigerant reclaim operation immediately. This immediate reaction, and large refrigerant storage capacity, offers very high levels of safety for end users, building occupants, as well as being environmentally friendly. No additional communication panels or software is required. This option should be implemented in any area that is not compliant with BS EN 378.

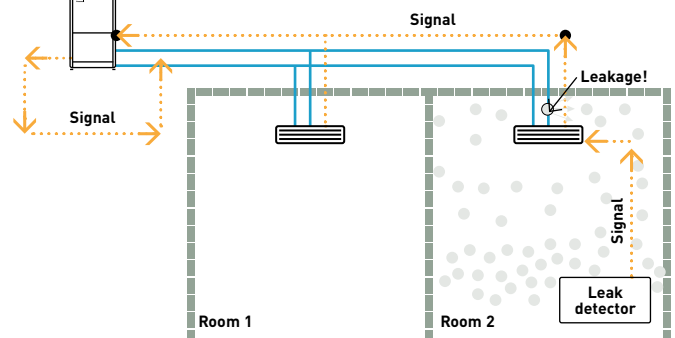

Indirect leak detection method: Unique PLC algorithm to determine refrigerant leakage

Pressure and temperature sensors constantly monitor the high / low pressure and discharge of the condensing unit to protect against potential leakage in areas not covered by leak detectors. The innovative algorithm is able to detect leakage of R410A based on abnormal changes in the following conditions, high and low pressure, and compressor discharge temperature. Once initiated via either direct or indirect detection, the unit will immediately close the liquid / discharge actuating ball valves, close the alarm terminals on the Pump Down PCB allowing an alarm to be raised at any nominated location. Reclaim of the refrigerant is via the suction line to the heat exchanger(s) of the outdoor unit(s), with any surplus refrigerant collected in the 30 l receiver tank. Once fully pumped down the suction line is closed and the unit awaits a 'Reset' and 'Recharge' command. Thanks to the simple installation and control, shown in Fig 1, Panasonic's ECOi Pump Down system can provide dramatic reduction in capital cost and installation time when compared to a standalone leak detection system, shown in Fig 2.

Fig 1: Panasonic's Pump Down system.

Fig 2: Standalone leak detection system.

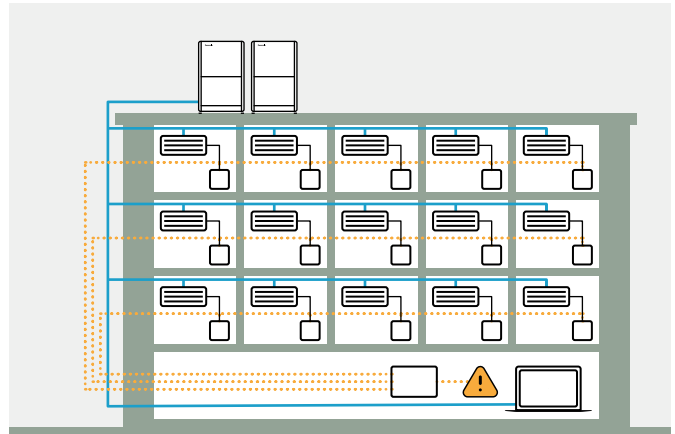
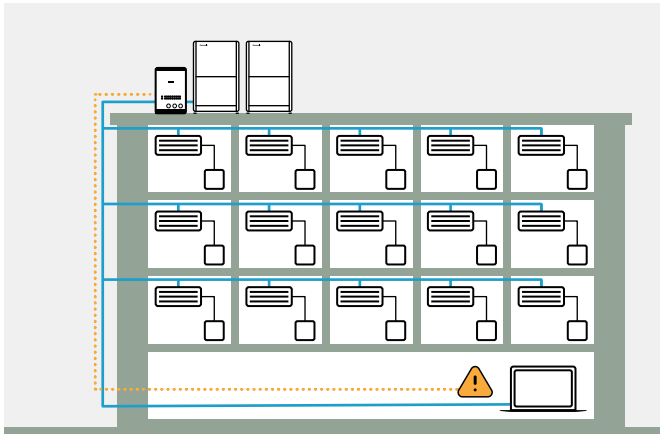

Quick and simple installation

The unit contains actuating ball valves, a 30 L storage vessel and PLC all housed in an IP54 rated encasement. Terminals in front of the unit allow easy wiring to the alarm terminal, high / low pressure transducers and discharge temperature sensor(s) of the condensing unit(s).

Reference	Description
PAW-PUD2W-1R	Pump Down system (2 way) for 1 outdoor unit
PAW-PUD2W-2R	Pump Down system (2 way) for 2 outdoor units
PAW-PUD2W-3R*	Pump Down system (2 way) for 3 outdoor units
PAW-PUD3W-1R	Pump Down system (3 way) for 1 outdoor unit
PAW-PUD3W-2R	Pump Down system (3 way) for 2 outdoor units
PAW-PUD3W-3R*	Pump Down system (3 way) for 3 outdoor units





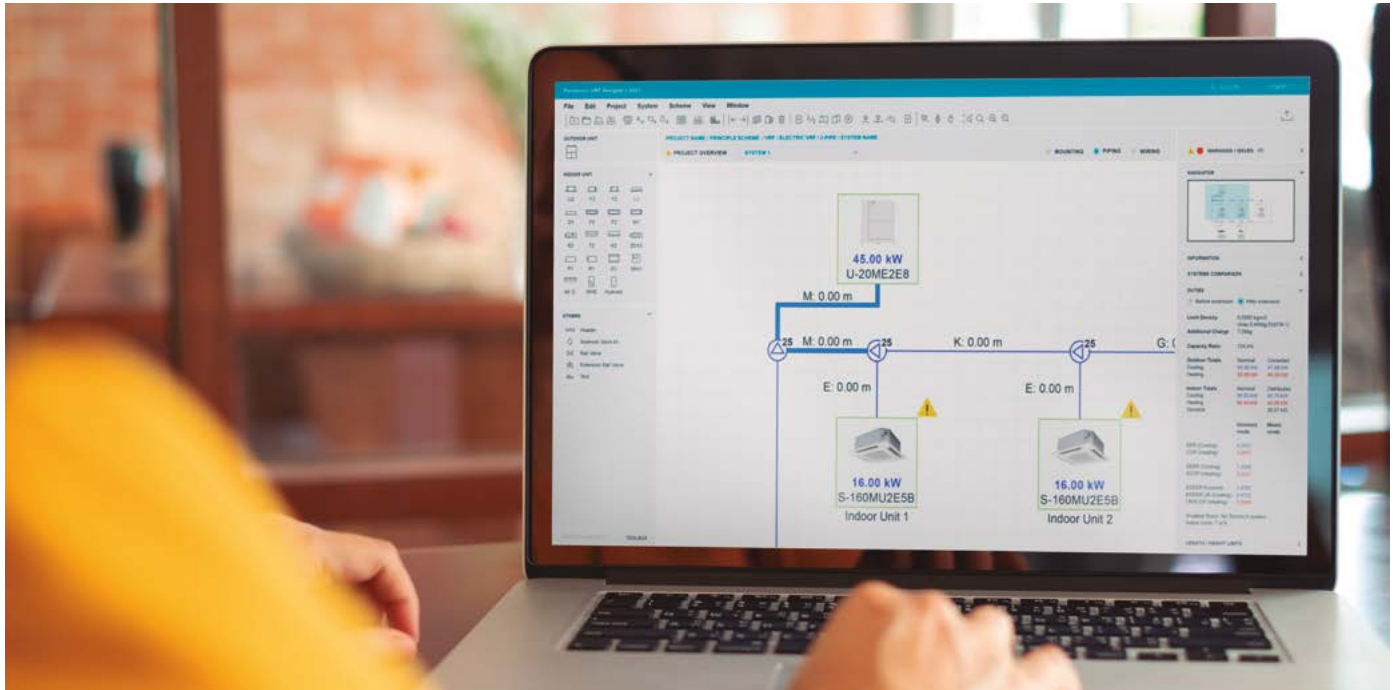

* Special order requiring the longer lead time than usual. For the detailed information, please contact an authorized Panasonic dealer.

New Panasonic DX PRO Designer

Leading software for architects, designers, and consultants, specializing in the design of commercial DX heating and cooling systems.



Cloud based solution: Access from anywhere 24/7/365, collaborative work with your team and the software is consistently updated to the latest version.

					
Cloud based tool.	Design on building floor drawing.	Auto piping and wiring diagram.	Performance calculation.	Comprehensive project report.	Floor drawing image import.

DX PRO Designer offers improved user experience and useful functions for the heating and cooling experts

- Seasonal performance calculation in accordance with ERP directive and EN14825 standard
- Designing heating and cooling systems for floor-level building design
- Automatic piping and wiring function
- Limit density check function in accordance with IEC 60335-2-40 / EN 378
- Comprehensive project report available
- Multi language supports

The software performs seasonal performance calculations, considering on-site conditions.



Download the comprehensive project report.



Let's try out the new DX PRO Designer*



* Panasonic PRO Club account is required.

The video for detailed information is ready!



Panasonic VRF service checker

Available to installers and commissioning companies, the VRF service checker is a communication interface to Panasonic VRF systems. This easy to manage tool checks all parameters of the system.

The VRF service checker.

- Connect anywhere on the S-Link for ECOi and Mini ECOi
- Search the S-Link to validate systems that are connected
- Monitor all indoor and outdoor units simultaneously on 1 screen
- Monitor all Temperature data, Pressure data, Valve position, and alarm status
- Data can be viewed in Graph or tabular display
- Controlling the indoor unit ON / OFF, MODE, SET POINT, FAN, and TEST mode
- Switch between various systems on the same communication S-Link (ECOi only)
- Monitor and record at a set interval
- Record and review the data at a later date
- Update Panasonic system software via ROM flash writer

The Panasonic VRF service checker is available from your local service partner.

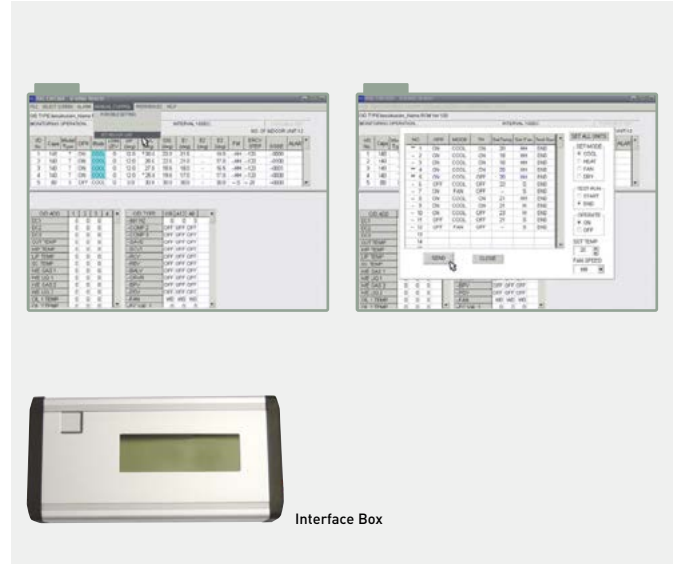

R22 Renewal















































Panasonic's advanced technology enables the system to work with previously installed pipe work by managing the working pressure within the system down to R22 (33 bar) levels, this ensures the system works safely and efficiently without loss of capacity.

The new equipment can offer increased COP / EER by using state of the art Inverter compressor and heat exchanger technology.

Having contacted your Panasonic supplier regarding pipe work restrictions, and gained approval to use the Panasonic Renewal System, there are three main tests that have to be carried out to ensure that the system can be used effectively. Firstly a thorough inspection of the pipe work must be carried out and any damage must be repaired. Secondly an oil test must be performed to ensure that the system has not been subject to a compressor burnout during its lifetime. Lastly a VRF Renewal Kit (CZ-SLK2) must be installed within the pipe work to ensure that the system is cleaned and free of oil remnants.



ECOi and ECO G systems indoor units range

Page	Indoor units	1,5 kW	2,2 kW	2,8 kW	3,6 kW	4,5 kW	5,6 kW
P. 313	U2 type 4 way 90x90 cassette · R32 / R410A						
			S-22MU2E5BN	S-28MU2E5BN	S-36MU2E5BN	S-45MU2E5BN	S-56MU2E5BN
P. 314	Y3 type 4 way 60x60 cassette · R32 / R410A						
		S-15MY3E	S-22MY3E	S-28MY3E	S-36MY3E	S-45MY3E	S-56MY3E
P. 315	L1 type 2 way cassette · R410A						
			S-22ML1E5	S-28ML1E5	S-36ML1E5	S-45ML1E5	S-56ML1E5
P. 316	D1 type 1 way cassette · R410A						
				S-28MD1E5	S-36MD1E5	S-45MD1E5	S-56MD1E5
P. 317	F3 type variable static pressure adaptive duct · R32 / R410A						
		S-15MF3E5BN S-15MF3E5AN	S-22MF3E5BN S-22MF3E5AN	S-28MF3E5BN S-28MF3E5AN	S-36MF3E5BN S-36MF3E5AN	S-45MF3E5BN S-45MF3E5AN	S-56MF3E5BN S-56MF3E5AN
P. 318	M1 type slim variable static pressure hide-away · R32 / R410A						
		S-15MM1E5B	S-22MM1E5B	S-28MM1E5B	S-36MM1E5B	S-45MM1E5B	S-56MM1E5B
P. 319	E2 type high static pressure hide- away · R410A						
P. 320	T2 type ceiling · R410A						
					S-36MT2E5A	S-45MT2E5A	S-56MT2E5A
P. 321	K2 type wall-mounted · R32 / R410A						
		S-15MK2E5B	S-22MK2E5B	S-28MK2E5B	S-36MK2E5B	S-45MK2E5B	S-56MK2E5B
P. 322	G1 type floor console · R410A						
			S-22MG1E5N	S-28MG1E5N	S-36MG1E5N	S-45MG1E5N	S-56MG1E5N
P. 323	P1 type floor-standing · R410A						
			S-22MP1E5	S-28MP1E5	S-36MP1E5	S-45MP1E5	S-56MP1E5
P. 324	R1 type concealed floor-standing · R410A						
			S-22MR1E5	S-28MR1E5	S-36MR1E5	S-45MR1E5	S-56MR1E5
P. 325	Hydrokit for ECOi, water at 45 °C · R410A						
P. 330	NEW energy recovery ventilation with DX coil - HRPT Series · R32 / R410A						
			PAW-HRPT40HX PAW-HRPT40 (2,5 kW)			PAW-HRPT80HX PAW-HRPT80 (5 kW)	
P. 331	Heat recovery with DX coil - ZDX Series · R410A						
				PAW-500ZDX3N (3 kW)	PAW-800ZDX3N (5,1 kW)	PAW-01KZDX3N (5,8 kW)	

+ OPTIONAL UNITS ON VENTILATION SECTION

6,0 kW

7,3 kW

9,0 kW

10,6 kW

11,2 kW

14,0 kW

16,0 kW

22,4 kW

28,0 kW



S-60MU2E5BN



S-73MU2E5BN



S-90MU2E5BN



S-112MU2E5BN



S-140MU2E5BN



S-160MU2E5BN



S-73ML1E5



S-73MD1E5



S-60MF3E5BN
S-60MF3E5AN



S-73MF3E5BN
S-73MF3E5AN



S-90MF3E5BN
S-90MF3E5AN



S-112MF3E5BN
S-112MF3E5AN



S-140MF3E5BN
S-140MF3E5AN



S-160MF3E5BN
S-160MF3E5AN



S-224ME2E5



S-280ME2E5



S-73MT2E5A



S-106MT2E5A



S-140MT2E5A

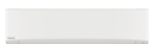

S-73MK2E5B

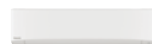

S-106MK2E5B



S-71MP1E5



S-71MR1E5



S-80MW1E5



S-125MW1E5



PAW-HRPT120HX
PAW-HRPT120 (7 kW)



PAW-HRPT160HX
PAW-HRPT160 (10 kW)



PAW-HRPT200HX
PAW-HRPT200 (12,5 kW)

4 way 90x90 cassette with nanoe X Generator Mark 3



Large capacity VRF. Trusted power and high efficiency. These Cassettes offer upgraded nanoe™ X technology and Econavi as accessories for making application space more comfortable and efficient.

Thanks to advances in design and technology such as the high performance turbo fan which is more efficient and silent, nanoe™ X technology, and the floor temperature and humidity sensor (Econavi) for more control, the Panasonic U2 type 4 way 90x90 cassette offers greater comfort.

The nanoe™ X performance varies depending on the room size, environment and usage and it may take several hours to reach the full effect. nanoe™ X is not medical device, local regulations on building design and sanitary recommendations must be followed.



Always fresh and clean air with nanoe™ X

The 4 way 90x90 cassette with nanoe™ X, when tested, has shown to inhibit hazardous substances by 92%, when compared to natural reduction*.

In addition to the 7 effects of nanoe™ X, the indoor unit can also be cleaned with a short operation of nanoe™ X + dry mode.

* Controllers (CZ-RTC5B or CZ-RTC6/BL/BLW) are required.

After cooling/drying operation, the inside of the indoor unit is automatically dried and nanoe™ X is activated to suppress mould growth.

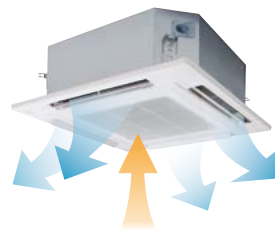

Operates the fan to discharge internal humidity.

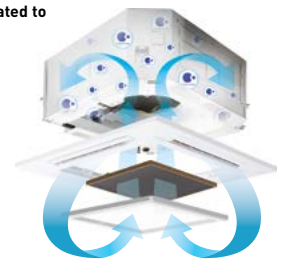

Operate the fan to circulate nanoe™ X internally.

Optional Econavi intelligent sensor

Human activity sensor and floor temperature sensor can reduce waste energy, by optimising air conditioner operation.

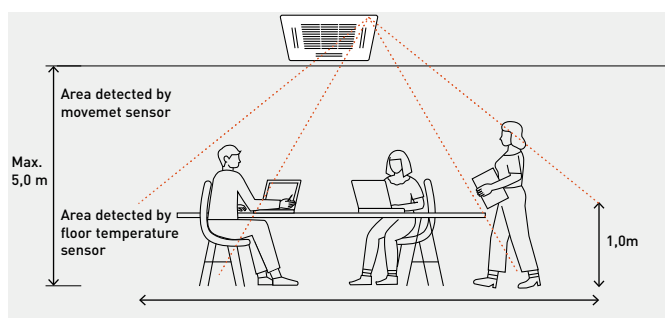

Advanced Econavi functions.

2 sensors (movement and floor temperature) can provide a reduction in wasted energy by means of effective control. The floor temperature can be detected with a ceiling height of up to 5 m.



Econavi exclusive panel. Optional (CZ-KPU3AW)



Floor temperature sensor.
This sensor detects average floor temperature and operates circulation if floor temperature is low.

Movement sensor.
This sensor detects the amount of human activity, and operates effectively.



Wired remote controller CZ-RTC5B or CZ-RTC6/BL is required.

Humidity sensor.

A humidity sensor positioned in the air inlet provides comfort and saves energy based on temperature and humidity.

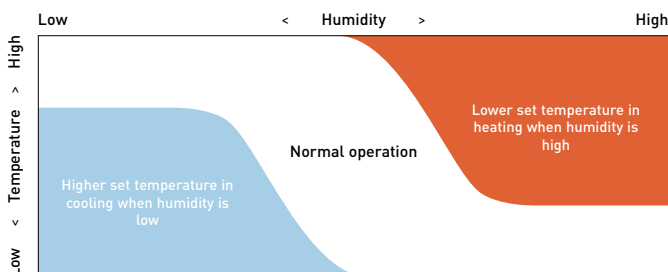

Group control, circulation function.

Circulating operation is activated when a room is unoccupied to evenly distribute air and minimize thermal stratification in both heating and cooling operation.

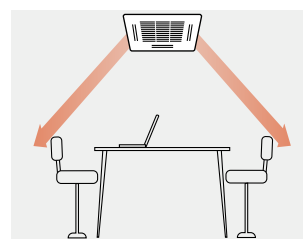

Circulation by detecting no movement (10 minutes).

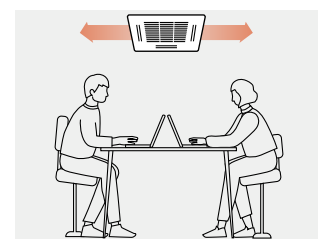

Indirect air flow by detecting movement.

U2 type 4 way 90x90 cassette · R32 / R410A

The 4 way 90x90 cassettes with integrated nanoe X Generator Mark 3 and design panel.

A modern flat panel design blends into any space. These cassettes provide high energy saving, comfort and better indoor air quality that satisfy customers.



+ COMPATIBLE WITH ALL PANASONIC CONNECTIVITY SOLUTIONS. FOR DETAILED INFORMATION GO TO THE CONTROL SYSTEMS SECTION

Indoor unit. S-***MU2E5BN			22	28	36	45	56	60	73	90	112	140	160
Cooling capacity	kW		2,2	2,8	3,6	4,5	5,6	6,0	7,3	9,0	11,2	14,0	16,0
Input power	W		20,00	20,00	20,00	20,00	25,00	35,00	40,00	40,00	95,00	95,00	105,00
Current	A		0,21	0,21	0,21	0,21	0,23	0,33	0,36	0,38	0,74	0,74	0,82
Heating capacity	kW		2,5	3,2	4,2	5,0	6,3	7,1	8,0	10,0	14,0	16,0	18,0
Input power	W		20,00	20,00	20,00	20,00	25,00	35,00	40,00	40,00	90,00	90,00	100,00
Current	A		0,20	0,20	0,20	0,20	0,22	0,32	0,35	0,37	0,72	0,72	0,80
Fan type			Turbo fan	Turbo fan	Turbo fan	Turbo fan	Turbo fan	Turbo fan	Turbo fan	Turbo fan	Turbo fan	Turbo fan	Turbo fan
nanoe X Generator			Mark 3	Mark 3	Mark 3	Mark 3	Mark 3	Mark 3	Mark 3	Mark 3	Mark 3	Mark 3	Mark 3
Air flow	Hi/ Med/ Lo	m ³ /min	12,8/12,1/11,5	12,8/12,1/11,5	14,5/13,0/11,5	15,5/13,0/11,5	16,5/13,5/11,5	21,0/16,0/13,0	22,5/16,0/13,0	23,0/18,5/14,0	36,0/26,0/20,0	36,0/26,0/20,0	37,0/28,0/24,0
Sound pressure		dB(A)	30/29/28	30/29/28	30/29/28	31/29/28	32/30/28	36/32/29	37/32/29	38/35/32	45/39/35	45/39/35	46/40/38
Sound power		dB(A)	45/44/43	45/44/43	45/44/43	46/44/43	47/45/43	51/47/44	52/47/44	53/50/47	60/54/50	60/54/50	61/55/53
Dimension (HxWxD)	Indoor	mm	256x840x840	256x840x840	256x840x840	256x840x840	256x840x840	256x840x840	256x840x840	256x840x840	319x840x840	319x840x840	319x840x840
	Panel	mm	33,5x950x950	33,5x950x950	33,5x950x950	33,5x950x950	33,5x950x950	33,5x950x950	33,5x950x950	33,5x950x950	33,5x950x950	33,5x950x950	33,5x950x950
Net weight (Panel)	kg		19 [5]	19 [5]	19 [5]	19 [5]	19 [5]	20 [5]	20 [5]	20 [5]	25 [5]	25 [5]	25 [5]
Piping diameter R32 model	Liquid	Inch (mm)	1/4 (6,35)	1/4 (6,35)	1/4 (6,35)	1/4 (6,35)	1/4 (6,35)	1/4 (6,35)	1/4 (6,35)	1/4 (6,35)	3/8 (9,52)	3/8 (9,52)	3/8 (9,52)
	Gas	Inch (mm)	1/2 (12,70)	1/2 (12,70)	1/2 (12,70)	1/2 (12,70)	1/2 (12,70)	1/2 (12,70)	1/2 (12,70)	1/2 (12,70)	5/8 (15,88)	5/8 (15,88)	5/8 (15,88)
Piping diameter R410A model	Liquid	Inch (mm)	1/4 (6,35)	1/4 (6,35)	1/4 (6,35)	1/4 (6,35)	1/4 (6,35)	3/8 (9,52) ¹⁾	3/8 (9,52) ¹⁾	3/8 (9,52) ¹⁾	3/8 (9,52)	3/8 (9,52)	3/8 (9,52)
	Gas	Inch (mm)	1/2 (12,70)	1/2 (12,70)	1/2 (12,70)	1/2 (12,70)	1/2 (12,70)	5/8 (15,88) ¹⁾	5/8 (15,88) ¹⁾	5/8 (15,88) ¹⁾	5/8 (15,88)	5/8 (15,88)	5/8 (15,88)

1) When the piping diameter is (liquid) Ø1/4 (6,35) - (gas) Ø1/2 (12,70), connect the liquid socket tube (Ø1/4 (6,35) - Ø3/8 (9,52)) to the liquid tubing side indoor unit and connect the gas socket tube (Ø1/2 (12,70) - Ø5/8 (15,88)) to the gas tubing side indoor unit. * Above values are in the case of nanoe™ X OFF.

Accessories	
CZ-RTC6W	CONEX wired remote controller (non-wireless), white
CZ-RTC6WBL	CONEX wired remote controller with Bluetooth®, white
CZ-RTC6	CONEX wired remote controller (non-wireless), black
CZ-RTC6BL	CONEX wired remote controller with Bluetooth®, black
CZ-RTC5B	Wired remote controller with Econavi function
CZ-RWS3 + CZ-RWRU3W	Infrared remote controller and receiver
PAW-RE2C4-MOD-WH	Room controller for hotel rooms, white
PAW-RE2C4-MOD-BK	Room controller for hotel rooms, black

Accessories	
PAW-RE2D4-WH	Display control for hotel rooms, white
PAW-RE2D4-BK	Display control for hotel rooms, black
CZ-KPU3W	Standard panel
CZ-KPU3AW	Econavi exclusive panel
CZ-CENSC1	Econavi energy saving sensor
CZ-FDU3+CZ-ATU2	Fresh air-intake kit
CZ-CGLSC1	Panasonic R32 refrigerant leak detector

Technical focus

- High performance turbo fan
- Lower noise in low fan operation
- Ceiling height up to 5,0 m
- Industry leading lightweight design
- Econavi: Temperature, humidity and activity sensor
- nanoe™ X (Generator Mark 3: 48 trillion hydroxyl radicals/sec) as standard for better indoor air quality, indoor unit internal cleaning with nanoe™ X and dry operation
- Powerful drain pump gives 850 mm lift
- Fresh air knockout
- Branch duct connection
- High volume fresh air input with optional air-intake plenum and chamber (CZ-FDU3+CZ-ATU2)

Panel design

Flat design, well-matched with interior aesthetic. 4-way individual flap control.

The drain pipe can be raised to a maximum height of 850 mm from the bottom of the ceiling

Integrated drain pump allows a drain height of 850 mm making the installation much easier.

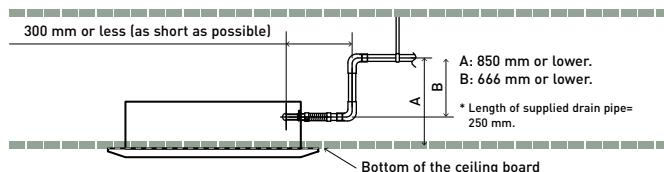

ECONAVI and INTERNET CONTROL: Optional.

Y3 type 4 way 60x60 cassette · R32 / R410A

Mini cassette with a modern panel design is available in VRF range.

The Y3 type not only perfectly matches with 600 x 600 mm ceiling grids but also provides the additional benefits of nanoe™ X, for better indoor air quality.

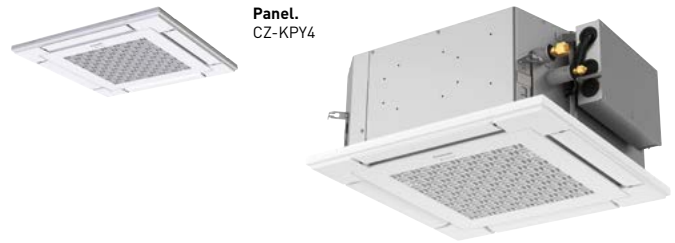

+ COMPATIBLE WITH ALL PANASONIC CONNECTIVITY SOLUTIONS. FOR DETAILED INFORMATION GO TO THE CONTROL SYSTEMS SECTION

Indoor unit			S-15MY3E	S-22MY3E	S-28MY3E	S-36MY3E	S-45MY3E	S-56MY3E
Cooling capacity	kW		1,5	2,2	2,8	3,6	4,5	5,6
Input power	W		19,00	20,00	21,00	22,00	30,00	42,00
Current	A		0,24	0,24	0,25	0,26	0,34	0,43
Heating capacity	kW		1,7	2,5	3,2	4,2	5,0	6,3
Input power	W		17,00	18,00	19,00	20,00	28,00	40,00
Current	A		0,21	0,21	0,22	0,23	0,31	0,40
Fan type			Turbo fan	Turbo fan	Turbo fan	Turbo fan	Turbo fan	Turbo fan
nanoe X Generator			Mark 3	Mark 3	Mark 3	Mark 3	Mark 3	Mark 3
Air flow	Cool (Hi/Med/Lo)	m³/min	8,5/7,0/6,0	8,7/7,0/6,0	9,0/7,5/6,0	9,5/7,8/6,0	11,5/9,0/6,5	13,5/10,5/8,0
	Heat (Hi/Med/Lo)	m³/min	8,5/7,0/6,0	8,7/7,0/6,0	9,0/7,5/6,0	9,5/7,8/6,0	11,5/9,0/6,5	13,5/10,5/8,0
Sound pressure	Hi/Med/Lo	dB(A)	33/30/28	33/30/28	34/30/28	35/31/28	39/34/30	42/37/33
Sound power	Hi/Med/Lo	dB(A)	48/45/43	48/45/43	49/45/43	50/46/43	54/49/45	57/52/48
Dimension (HxWxD) ¹⁾	Indoor	mm	243x575x575	243x575x575	243x575x575	243x575x575	243x575x575	243x575x575
	Panel	mm	30x625x625	30x625x625	30x625x625	30x625x625	30x625x625	30x625x625
Net weight		kg	17,8(15+2,8)	17,8(15+2,8)	17,8(15+2,8)	17,8(15+2,8)	17,8(15+2,8)	17,8(15+2,8)
Piping diameter	Liquid	Inch (mm)	1/4(6,35)	1/4(6,35)	1/4(6,35)	1/4(6,35)	1/4(6,35)	1/4(6,35)
	Gas	Inch (mm)	1/2(12,70)	1/2(12,70)	1/2(12,70)	1/2(12,70)	1/2(12,70)	1/2(12,70)

1) Unit height is 230 mm, but need 243 mm height in ceiling space for its installation.

Accessories	
CZ-RTC6W	CONEX wired remote controller (non-wireless), white
CZ-RTC6WBL	CONEX wired remote controller with Bluetooth®, white
CZ-RTC6	CONEX wired remote controller (non-wireless), black
CZ-RTC6BL	CONEX wired remote controller with Bluetooth®, black
CZ-RTC5B	Wired remote controller with Econavi function
CZ-RWS3 + CZ-RWR3	Infrared remote controller and receiver
PAW-RE2C4-MOD-WH	Room controller for hotel rooms, white

Accessories	
PAW-RE2C4-MOD-BK	Room controller for hotel rooms, black
PAW-RE2D4-WH	Display control for hotel rooms, white
PAW-RE2D4-BK	Display control for hotel rooms, black
CZ-CENSC1	Econavi energy saving sensor
CZ-CGLSC1	Panasonic R32 refrigerant leak detector
CZ-KPY4	Panel for 4 way 60x60 cassette

Technical focus

- Built-in drain pump
- DC drain pump and float switch to reduce the noise
- nanoe™ X (Generator Mark 3: 48 trillion hydroxyl radicals/sec) as standard for better indoor air quality
- Indoor unit internal cleaning with nanoe™ X plus dry operation

Compact and stylish design

- Required ceiling depth of only 250 mm ¹⁾
- Exposed area is only 30 mm

1) Installation dimension.

Individual flap control

Better control of the air flow with 4 motors, providing individual flap control.

Perfect air distribution without direct airflow, to reduce the feeling of cold drafts.

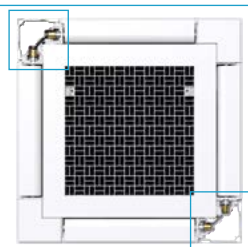

Internal cleaning function

When cooling or dry operation stopped, internal drying and nanoe™ X circulation airflow is activated in order to suppress the mould proliferation inside the unit (airflow passage, fan, heat exchanger)*.

* Depending on the installation environment or operating hours, mould proliferation or inhabitation of mould growth will be changed.

After cooling/drying operation, the inside of the indoor unit is automatically dried and nanoe™ X is activated to suppress mould growth.

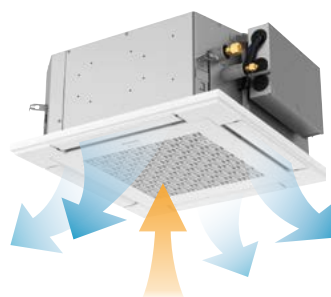

Operates the fan to discharge internal humidity.

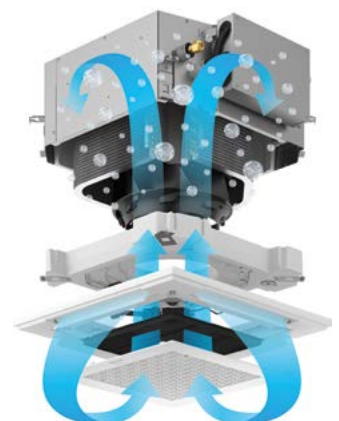

Operate the fan to circulate nanoe™ X internally.



ECONAVI and INTERNET CONTROL: Optional.

L1 type 2 way cassette - R410A

Slim, compact and lightweight units.

Remarkable size and weight reductions have been achieved by improvement of the design around the fan, the weight of all models now just 30 kg.



+ COMPATIBLE WITH ALL PANASONIC CONNECTIVITY SOLUTIONS. FOR DETAILED INFORMATION GO TO THE CONTROL SYSTEMS SECTION

Indoor unit			S-22ML1E5	S-28ML1E5	S-36ML1E5	S-45ML1E5	S-56ML1E5	S-73ML1E5
Cooling capacity		kW	2,2	2,8	3,6	4,5	5,6	7,3
Input power		W	90,00	92,00	93,00	97,00	97,00	145,00
Current		A	0,45	0,45	0,45	0,45	0,45	0,65
Heating capacity		kW	2,5	3,2	4,2	5,0	6,3	8,0
Input power		W	58,00	60,00	61,00	65,00	65,00	109,00
Current		A	0,29	0,29	0,29	0,29	0,29	0,48
Fan type			Sirocco fan	Sirocco fan	Sirocco fan	Sirocco fan	Sirocco fan	Sirocco fan
Air flow	Hi/Med/Lo	m ³ /min	8,0/7,0/6,0	9,0/8,0/7,0	9,7/8,7/7,7	11,0/9,0/8,0	11,0/9,0/8,0	19,0/16,0/14,0
Sound pressure	Hi/Med/Lo	dB(A)	30/27/24	33/29/26	34/31/28	35/33/29	35/33/29	38/35/33
Dimension (HxWxD)	Indoor	mm	350x840x600	350x840x600	350x840x600	350x840x600	350x840x600	350x1140x600
	Panel	mm	8x1060x680	8x1060x680	8x1060x680	8x1060x680	8x1060x680	8x1360x680
Net weight (Panel)		kg	26 (8)	26 (8)	26 (8)	26 (8)	26 (8)	26 (8)
Piping diameter	Liquid	Inch (mm)	1/4 (6,35)	1/4 (6,35)	1/4 (6,35)	1/4 (6,35)	1/4 (6,35)	3/8 (9,52)
	Gas	Inch (mm)	1/2 (12,70)	1/2 (12,70)	1/2 (12,70)	1/2 (12,70)	1/2 (12,70)	5/8 (15,88)

Accessories

CZ-RTC6W	CONEX wired remote controller (non-wireless), white
CZ-RTC6WBL	CONEX wired remote controller with Bluetooth®, white
CZ-RTC6	CONEX wired remote controller (non-wireless), black
CZ-RTC6BL	CONEX wired remote controller with Bluetooth®, black
CZ-RTC5B	Wired remote controller with Econavi function
CZ-RWS3 + CZ-RWRL3	Infrared remote controller and receiver

Accessories

PAW-RE2C4-MOD-WH	Room controller for hotel rooms, white
PAW-RE2C4-MOD-BK	Room controller for hotel rooms, black
PAW-RE2D4-WH	Display control for hotel rooms, white
PAW-RE2D4-BK	Display control for hotel rooms, black
CZ-02KPL2	Panel for S-22 to S-56 models
CZ-03KPL2	Panel for S-73 model

Technical focus

- Air flow and distribution is automatically altered depending on the operational mode of the unit
- Drain pump provides up to 500 mm lift height
- Simplified maintenance

Auto flap control

Air flow and distribution is automatically altered depending on the operational mode of the unit.

Simplified maintenance

The drain pan is equipped with site wiring and can be removed. The fan case has a split construction, and the fan motor can be removed easily when the lower case is removed.

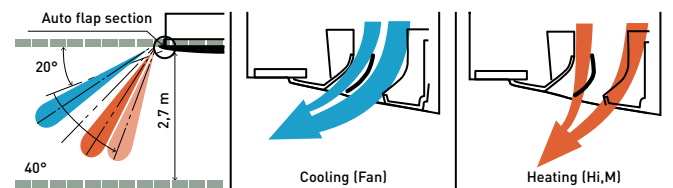

Drain pump provides up to 500 mm lift height

Maintenance of the drain pump is possible from two sides, from the left side (piping side) and from the inside of the unit.

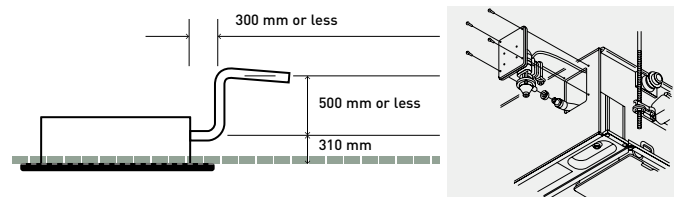

INTERNET CONTROL: Optional.

Rating conditions: Cooling indoor 27 °C DB / 19 °C WB. Cooling outdoor 35 °C DB / 24 °C WB. Heating indoor 20 °C DB. Heating outdoor 7 °C DB / 6 °C WB. (DB: Dry Bulb; WB: Wet Bulb). Specifications subject to change without notice. For detailed information about ErP / Energy Labelling, please visit our websites www.aircon.panasonic.eu or www.ptc.panasonic.eu.

D1 type 1 way cassette · R410A

Designed for installation within the ceiling void, the D1 range of slimline 1 way blow cassettes feature powerful yet quiet fans for installation of up to 4,2 m.



+ COMPATIBLE WITH ALL PANASONIC CONNECTIVITY SOLUTIONS. FOR DETAILED INFORMATION GO TO THE CONTROL SYSTEMS SECTION

Indoor unit			S-28MD1E5	S-36MD1E5	S-45MD1E5	S-56MD1E5	S-73MD1E5
Cooling capacity		kW	2,8	3,6	4,5	5,6	7,3
Input power		W	51,00	51,00	51,00	60,00	87,00
Current		A	0,39	0,39	0,39	0,46	0,70
Heating capacity		kW	3,2	4,2	5,0	6,3	8,0
Input power		W	40,00	40,00	40,00	48,00	76,00
Current		A	0,35	0,35	0,35	0,41	0,65
Fan type			Sirocco fan	Sirocco fan	Sirocco fan	Sirocco fan	Sirocco fan
Air flow	Hi/Med/Lo	m ³ /min	12,0/10,0/9,0	12,0/10,0/9,0	12,0/11,0/10,0	13,0/11,5/10,0	18,0/15,0/13,0
Sound pressure	Hi/Med/Lo	dB(A)	36/34/33	36/34/33	36/35/34	38/36/34	45/40/36
Dimension (HxWxD)	Indoor	mm	200x1000x710	200x1000x710	200x1000x710	200x1000x710	200x1000x710
	Panel	mm	20x1230x800	20x1230x800	20x1230x800	20x1230x800	20x1230x800
Net weight (Panel)		kg	23,5(7,5)	23,5(7,5)	23,5(7,5)	23,5(7,5)	24,5(7,5)
Piping diameter	Liquid	Inch (mm)	1/4(6,35)	1/4(6,35)	1/4(6,35)	1/4(6,35)	3/8(9,52)
	Gas	Inch (mm)	1/2(12,70)	1/2(12,70)	1/2(12,70)	1/2(12,70)	5/8(15,88)

Accessories	
CZ-RTC6W	CONEX wired remote controller (non-wireless), white
CZ-RTC6WBL	CONEX wired remote controller with Bluetooth®, white
CZ-RTC6	CONEX wired remote controller (non-wireless), black
CZ-RTC6BL	CONEX wired remote controller with Bluetooth®, black
CZ-RTC5B	Wired remote controller with Econavi function
CZ-RWS3 + CZ-RWRD3	Infrared remote controller and receiver

Accessories	
PAW-RE2C4-MOD-WH	Room controller for hotel rooms, white
PAW-RE2C4-MOD-BK	Room controller for hotel rooms, black
PAW-RE2D4-WH	Display control for hotel rooms, white
PAW-RE2D4-BK	Display control for hotel rooms, black
CZ-KPD2	Panel

Technical focus

- Ultra-Slim
- Suitable for standard and high ceilings
- Built-in drain pump provides 590 mm lift
- Easy to install and maintain
- Hanging height can be easily adjusted
- Uses a DC fan motor to improve energy-efficiency

Drain height

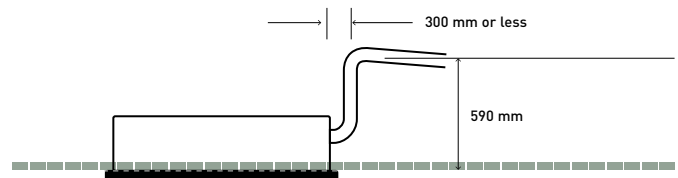

With 2 types of air-blow systems, the units can be used in various ways



1. One-direction "down-blow" system.

Powerful one-direction "down-blow" system reaches the floor even from high ceilings (up to 4,2 m).



2. Two-direction ceiling-mounted system.

"Down-blow" and "front-blow" systems are combined in a ceiling-mounted unit to blow air over a wide area.



INTERNET CONTROL: Optional.

F3 type variable static pressure adaptive duct · R32 / R410A

Design adaptive ducted F3 range.

2 installation possibilities (horizontal / vertical) with high ESP 150 Pa allows for flexible installation.



+ COMPATIBLE WITH ALL PANASONIC CONNECTIVITY SOLUTIONS. FOR DETAILED INFORMATION GO TO THE CONTROL SYSTEMS SECTION

R32 unit. S-***MF3E5BN		15	22	28	36	45	56	60	73	90	112	140	160	
R410A unit. S-***MF3E5AN														
Cooling capacity	kW	1,5	2,2	2,8	3,6	4,5	5,6	6,0	7,3	9,0	11,2	14,0	16,0	
Input power	W	60,00	60,00	60,00	60,00	60,00	89,00	79,00	79,00	136,00	265,00	265,00	330,00	
Current	A	0,45	0,45	0,45	0,45	0,45	0,63	0,52	0,52	0,90	1,76	1,76	2,14	
Heating capacity	kW	1,7	2,5	3,2	4,2	5,0	6,3	7,1	8,0	10,0	12,5	16,0	18,0	
Input power	W	60,00	60,00	60,00	60,00	60,00	89,00	79,00	79,00	136,00	265,00	265,00	330,00	
Current	A	0,45	0,45	0,45	0,45	0,45	0,63	0,52	0,52	0,90	1,76	1,76	2,14	
R32 leakage sensors ¹⁾		2	2	2	2	2	2	2	2	2	2	2	2	
Fan type		Sirocco fan	Sirocco fan	Sirocco fan	Sirocco fan	Sirocco fan	Sirocco fan	Sirocco fan	Sirocco fan	Sirocco fan	Sirocco fan	Sirocco fan	Sirocco fan	
nanoe X Generator		Mark 3	Mark 3	Mark 3	Mark 3	Mark 3	Mark 3	Mark 3	Mark 3	Mark 3	Mark 3	Mark 3	Mark 3	
External static pressure	Pa	30 (10-150)	30 (10-150)	30 (10-150)	30 (10-150)	30 (10-150)	30 (10-150)	30 (10-150)	30 (10-150)	40 (10-150)	50 (10-150)	50 (10-150)	50 (10-150)	
Air flow ²⁾	Hi/ Med/ Lo	m ³ /min	12,8/11,0/ 8,0	12,8/11,0/ 8,0	14,0/12,0/ 8,0	14,0/12,0/ 8,0	14,0/12,0/ 8,0	16,0/14,0/ 10,0	21,0/18,0/ 15,0	21,0/18,0/ 15,0	25,0/23,0/ 16,0	37,0/32,0/ 26,0	37,0/32,0/ 26,0	40,0/34,0/ 28,0
Sound pressure		dB(A)	31/28/20	31/28/20	31/28/20	31/28/20	31/28/20	35/32/24	31/28/23	31/28/23	35/33/25	41/36/32	41/36/32	43/37/33
Sound power		dB(A)	54/51/43	54/51/43	54/51/43	54/51/43	54/51/43	58/55/47	54/51/46	54/51/46	58/56/48	64/59/55	64/59/55	66/60/56
Dimension (H x W x D)		mm	250 x 800 x 730	250 x 800 x 730	250 x 800 x 730	250 x 800 x 730	250 x 800 x 730	250 x 800 x 730	250 x 1000 x 730	250 x 1000 x 730	250 x 1000 x 730	250 x 1400 x 730	250 x 1400 x 730	250 x 1400 x 730
Net weight		kg	26	26	26	26	26	26	31	31	31	40	40	40
Piping diameter	Liquid	Inch (mm)	1/4 (6,35)	1/4 (6,35)	1/4 (6,35)	1/4 (6,35)	1/4 (6,35)	1/4 (6,35)	1/4 (6,35)	1/4 (6,35)	1/4 (6,35)	3/8 (9,52)	3/8 (9,52)	3/8 (9,52)
R32 model	Gas	Inch (mm)	1/2 (12,70)	1/2 (12,70)	1/2 (12,70)	1/2 (12,70)	1/2 (12,70)	1/2 (12,70)	1/2 (12,70)	1/2 (12,70)	1/2 (12,70)	5/8 (15,88)	5/8 (15,88)	5/8 (15,88)
Piping diameter	Liquid	Inch (mm)	1/4 (6,35)	1/4 (6,35)	1/4 (6,35)	1/4 (6,35)	1/4 (6,35)	1/4 (6,35)	3/8 (9,52)	3/8 (9,52)	3/8 (9,52)	3/8 (9,52)	3/8 (9,52)	3/8 (9,52)
R410A model	Gas	Inch (mm)	1/2 (12,70)	1/2 (12,70)	1/2 (12,70)	1/2 (12,70)	1/2 (12,70)	1/2 (12,70)	5/8 (15,88)	5/8 (15,88)	5/8 (15,88)	5/8 (15,88)	5/8 (15,88)	5/8 (15,88)

1) Only available in the R32 version. 2) Value referred to standard settings at shipment (H curve 8, M curve 5, L curve 1).

Accessories	
CZ-RTC6W	CONEX wired remote controller (non-wireless), white
CZ-RTC6WBL	CONEX wired remote controller with Bluetooth®, white
CZ-RTC6	CONEX wired remote controller (non-wireless), black
CZ-RTC6BL	CONEX wired remote controller with Bluetooth®, black
CZ-RTC5B	Wired remote controller with Econavi function
CZ-RWS3 + CZ-RWRC3	Infrared remote controller and receiver
PAW-RE2C4-MOD-WH	Room controller for hotel rooms, white

Accessories	
PAW-RE2C4-MOD-BK	Room controller for hotel rooms, black
PAW-RE2D4-WH	Display control for hotel rooms, white
PAW-RE2D4-BK	Display control for hotel rooms, black
CZ-CENSC1	Econavi energy saving sensor
PAW-APF800F	NEW BION air pollutant filter for MF3 15, 22, 28, 36, 45 and 56
PAW-APF1000F	NEW BION air pollutant filter for MF3 60 and 73
PAW-APF1400F	NEW BION air pollutant filter for MF3 90, 106, 112, 140 and 160

Technical focus

- 4 installation possibilities with horizontal and vertical mounting, plus selectable rear or bottom air inlet
- Industry leading low noise with super quiet operation, minimum 20 dB(A)
- Only 250 mm height and lightweight unit from, 26 to 40 kg
- Integrated Panasonic R32 refrigerant leak detectors ¹⁾
- Improved drain pan suitable for both horizontal / vertical installation
- Drain pump included ²⁾
- nanoe™ X (Generator Mark 3: 48 trillion hydroxyl radicals/sec) as standard, effective even with duct connections up to 10 m with 3 x 90° bends ³⁾
- **NEW** BION air pollutant filter for certain types of pollutants, such as nitrogen dioxide (NO₂), nitrogen oxides (NO_x) and Ozone (O₃) (optional)

1) Only available in the R32 version. 2) For use with horizontal installation only. 3) Panasonic internal survey.

Vertical Installation

Vertical installation option. Variable external static pressure to support ducted installations with bends.

* Vertical installation requires additional settings on field, please check the installation manual.



Improved drain pan design

Drain pan is shared in both cases horizontal and vertical installation. No need to modify the unit.

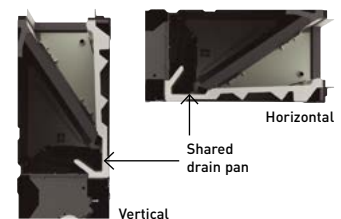

ECONAVI and INTERNET CONTROL: Optional.

Rating conditions: Cooling indoor 27 °C DB / 19 °C WB. Cooling outdoor 35 °C DB / 24 °C WB. Heating indoor 20 °C DB. Heating outdoor 7 °C DB / 6 °C WB. (DB: Dry Bulb, WB: Wet Bulb). Specifications subject to change without notice. For detailed information about ErP / Energy Labelling, please visit our websites www.aircon.panasonic.eu or www.ptc.panasonic.eu.

M1 type slim variable static pressure hide-away concealed duct · R32 / R410A

The ultra slim M1 type is one of the leading products of its type in the industry.

With a depth of only 200 mm it provides greater flexibility and can be used in far more applications.



+ COMPATIBLE WITH ALL PANASONIC CONNECTIVITY SOLUTIONS. FOR DETAILED INFORMATION GO TO THE CONTROL SYSTEMS SECTION

Indoor unit			S-15MM1E5B	S-22MM1E5B	S-28MM1E5B	S-36MM1E5B	S-45MM1E5B	S-56MM1E5B
Cooling capacity	kW		1,5	2,2	2,8	3,6	4,5	5,6
Input power	W		36,00	36,00	40,00	42,00	49,00	64,00
Current	A		0,26	0,26	0,30	0,31	0,37	0,48
Heating capacity	kW		1,7	2,5	3,2	4,2	5,0	6,3
Input power	W		26,00	26,00	30,00	32,00	39,00	54,00
Current	A		0,23	0,23	0,27	0,28	0,34	0,45
Fan type			Sirocco fan	Sirocco fan	Sirocco fan	Sirocco fan	Sirocco fan	Sirocco fan
Air flow	Hi/Med/Lo	m ³ /min	8,0/7,0/6,0	8,0/7,0/6,0	8,5/7,5/6,5	9,0/8,0/7,0	10,5/9,5/8,0	12,5/11,5/10,0
External static pressure		Pa	10(30)	10(30)	15(30)	15(40)	15(40)	15(40)
Sound pressure	Hi/Med/Lo ¹⁾	dB(A)	28/27/25 (30/29/27)	28/27/25 (30/29/27)	30/29/27 (32/31/29)	32/30/28 (34/32/30)	34/32/30 (36/34/32)	35/33/31 (37/35/32)
Sound power	Hi/Med/Lo	dB(A)	43/42/40	43/42/40	45/44/42	47/45/43	49/47/45	50/48/46
Dimension	H x W x D	mm	200 x 750 x 640	200 x 750 x 640	200 x 750 x 640	200 x 750 x 640	200 x 750 x 640	200 x 750 x 640
Net weight		kg	19	19	19	19	19	19
Piping diameter	Liquid	Inch (mm)	1/4(6,35)	1/4(6,35)	1/4(6,35)	1/4(6,35)	1/4(6,35)	1/4(6,35)
	Gas	Inch (mm)	1/2(12,70)	1/2(12,70)	1/2(12,70)	1/2(12,70)	1/2(12,70)	1/2(12,70)

1) By DIP switches or by RC setting.

Accessories	
CZ-RTC6W	CONEX wired remote controller (non-wireless), white
CZ-RTC6WBL	CONEX wired remote controller with Bluetooth®, white
CZ-RTC6	CONEX wired remote controller (non-wireless), black
CZ-RTC6BL	CONEX wired remote controller with Bluetooth®, black
CZ-RTC5B	Wired remote controller with Econavi function
CZ-RWS3 + CZ-RWRC3	Infrared remote controller and receiver

Accessories	
PAW-RE2C4-MOD-WH	Room controller for hotel rooms, white
PAW-RE2C4-MOD-BK	Room controller for hotel rooms, black
PAW-RE2D4-WH	Display control for hotel rooms, white
PAW-RE2D4-BK	Display control for hotel rooms, black
CZ-CENSC1	Econavi energy saving sensor
CZ-CGLSC1	Panasonic R32 refrigerant leak detector

Technical focus

- Ultra-slim profile: 200 mm for all models
- DC fan motor greatly reduces power consumption
- Ideal for hotel application with very narrow false ceilings
- Easy maintenance and service by external electrical box

- Up to 40 Pa static pressure enables ductwork to be fitted
- Includes drain pump

In addition, its high-efficiency and extremely quiet sound levels make it very popular with many users, including hotels and small offices.

Air outlet and inlet plenum

	Diameters	Air outlet plenum	Diameters	Air inlet plenum
22, 28 and 36	2 x Ø200	CZ-DUMPA22MMS2	2 x Ø200	CZ-DUMPA22MMR2
45 and 56	3 x Ø160	CZ-DUMPA45MMS3		

* Plenums installed with an R32 Mini ECOi system may only be used when no Panasonic R32 refrigerant leak detector is required. Please refer to technical data manual for refrigerant installation requirements.

Ultra-slim profile for all models

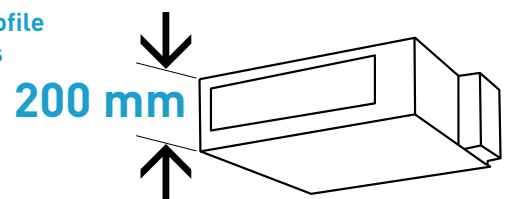

Drain pump with increased power!

By adoption of a high-lift drain pump, the drain piping can achieve up to 500 mm lift from the outlet port of the unit.

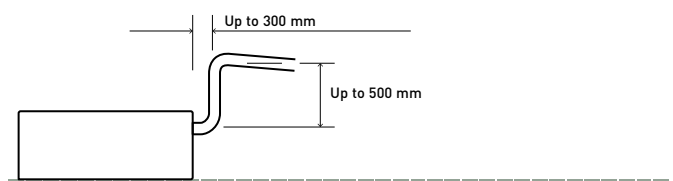

ECONAVI and INTERNET CONTROL: Optional.

E2 type high static pressure hide-away · R410A

High pressure duct and 100% Fresh air duct function.

The E2 range of ducted units offers improved design flexibility for extended duct layouts as a result of their increased external static pressures whilst reducing energy consumption.



+ COMPATIBLE WITH ALL PANASONIC CONNECTIVITY SOLUTIONS. FOR DETAILED INFORMATION GO TO THE CONTROL SYSTEMS SECTION

Type	100% Fresh air duct function (by using Kit for 100% fresh air)				High pressure duct					
	S-224ME2E5		S-280ME2E5		S-224ME2E5		S-280ME2E5			
Indoor unit		Cooling	Heating	Cooling	Heating	Cooling	Heating	Cooling	Heating	
Capacity	kW	22,4	21,2	28,0	26,5	22,4	25,0	28,0	31,5	
Input power	W	290,00	290,00	350,00	350,00	440,00	440,00	715,00	715,00	
Current	A	1,85	1,85	2,20	2,20	2,45	2,45	3,95	3,95	
Air flow	Hi/Med/Lo	m ³ /min 28,3/—/—		35,0/—/—		56,0/51,0/44,0		72,0/63,0/53,0		
External static pressure	Pa	200		200		140(60-270) ¹⁾		140(72-270) ¹⁾		
Sound pressure ²⁾	Hi/Med/Lo	dB(A) 43/—/—		44/—/—		45/43/41		49/47/43		
Sound power	Hi/Med/Lo	dB(A) 75/—/—		76/—/—		77/75/73		81/79/75		
Dimension	H x W x D	mm 479 x 1453 x 1205		479 x 1453 x 1205		479 x 1453 x 1205		479 x 1453 x 1205		
Net weight	kg	102		106		102		106		
Piping diameter	Liquid	Inch (mm)	3/8(9,52)		3/8(9,52)		3/8(9,52)		3/8(9,52)	
	Gas	Inch (mm)	3/4(19,05)		7/8(22,22)		3/4(19,05)		7/8(22,22)	

Rating Conditions for 100% Fresh air duct function: Cooling Outdoor 33 °C DB / 28 °C WB. Heating Outdoor 0 °C DB / -2,9 °C WB.

1) Available to select the setting by initial setup. 2) Values with 140 Pa setting. * No filter included. ** No compatible with 3-Pipe ECO G GF3.

Accessories

CZ-RTC6W	CONEX wired remote controller (non-wireless), white
CZ-RTC6WBL	CONEX wired remote controller with Bluetooth®, white
CZ-RTC6	CONEX wired remote controller (non-wireless), black
CZ-RTC6BL	CONEX wired remote controller with Bluetooth®, black
CZ-RTC5B	Wired remote controller with Econavi function
CZ-RWS3 + CZ-RWRC3	Infrared remote controller and receiver

Accessories

PAW-RE2C4-MOD-WH	Room controller for hotel rooms, white
PAW-RE2C4-MOD-BK	Room controller for hotel rooms, black
PAW-RE2D4-WH	Display control for hotel rooms, white
PAW-RE2D4-BK	Display control for hotel rooms, black
CZ-CENSC1	Econavi energy saving sensor

Technical focus

- No need of rap valves for standard operation
- 100% fresh air duct function*
- DC fan motor for more savings
- Complete flexibility for ductwork design
- Can be located within a weatherproof housing for external installation
- Air OFF sensor avoids cold air dumping
- Configurable air temperature control

* Rap valves required, see 100% fresh air duct function below.

100% fresh air duct function

The E2 duct with 100% fresh air duct function have exceptional discharge temperature.

	Discharge Range		
	Min	Max	Default
Cooling	15 °C	24 °C	18 °C
Heating	17 °C	45 °C	40 °C

System example

An inspection port (450 x 450 mm or more) is required at the lower side of the indoor unit body (field supply).



Plenums

Air outlet plenum (suitable for rigid + flexible duct)		
	Number of exits with diameters	Model
S-224ME2E5	1 x 500 mm	CZ-TREMIESPW705
S-280ME2E5	1 x 500 mm	CZ-TREMIESPW706

Kit for 100% fresh air function

Kit for 2 way systems		Kit for 3 way systems	
2x CZ-P160RVK2	Rap valve kit	2x CZ-P160HR3	3 way valve kit
2x CZ-CAPE2	3 way control PCB	2x CZ-CAPE2	3 way control PCB
CZ-P680BK2BM	Distribution joint kit	CZ-P680BH2BM	Distribution joint kit
	1x remote controller		1x remote controller



ECONAVI and INTERNET CONTROL: Optional.

Rating conditions: Cooling indoor 27 °C DB / 19 °C WB. Cooling outdoor 35 °C DB / 24 °C WB. Heating indoor 20 °C DB. Heating outdoor 7 °C DB / 6 °C WB. (DB: Dry Bulb; WB: Wet Bulb). Specifications subject to change without notice. For detailed information about ErP / Energy Labelling, please visit our websites www.aircon.panasonic.eu or www.ptc.panasonic.eu.

T2 type ceiling · R410A

The T2 type ceiling mounted units feature a DC fan motor for increased efficiency and reduced operating sound levels.

All the units are the same height and depth for a uniform appearance in mixed installations, and feature a fresh air knockout for improved air quality.



+ COMPATIBLE WITH ALL PANASONIC CONNECTIVITY SOLUTIONS. FOR DETAILED INFORMATION GO TO THE CONTROL SYSTEMS SECTION

Indoor unit		S-36MT2E5A	S-45MT2E5A	S-56MT2E5A	S-73MT2E5A	S-106MT2E5A	S-140MT2E5A	
Cooling capacity	kW	3,6	4,5	5,6	7,3	10,6	14,0	
Input power	W	35,00	40,00	40,00	55,00	80,00	100,00	
Current	A	0,36	0,38	0,38	0,44	0,67	0,79	
Heating capacity	kW	4,2	5,0	6,3	8,0	11,4	16,0	
Input power	W	35,00	40,00	40,00	55,00	80,00	100,00	
Current	A	0,36	0,38	0,38	0,44	0,67	0,79	
Fan type		Sirocco fan	Sirocco fan	Sirocco fan	Sirocco fan	Sirocco fan	Sirocco fan	
Air flow	Hi/Med/Lo	m ³ /min	14,0/12,0/10,5	15,0/12,5/10,5	15,0/12,5/10,5	21,0/18,0/15,5	30,0/25,0/23,0	32,0/28,0/24,0
Sound pressure	Hi/Med/Lo	dB(A)	36/32/30	37/33/30	37/33/30	39/35/33	42/37/36	46/40/37
Sound power	Hi/Med/Lo	dB(A)	54/50/48	55/51/48	55/51/48	57/53/51	60/55/54	62/58/55
Dimension	HxWxD	mm	235x960x690	235x960x690	235x960x690	235x1275x690	235x1590x690	235x1590x690
Net weight		kg	27	27	27	33	40	40
Piping diameter	Liquid	Inch (mm)	1/4(6,35)	1/4(6,35)	1/4(6,35)	3/8(9,52)	3/8(9,52)	3/8(9,52)
	Gas	Inch (mm)	1/2(12,70)	1/2(12,70)	1/2(12,70)	5/8(15,88)	5/8(15,88)	5/8(15,88)

Accessories

CZ-RTC6W	CONEX wired remote controller (non-wireless), white
CZ-RTC6WBL	CONEX wired remote controller with Bluetooth®, white
CZ-RTC6	CONEX wired remote controller (non-wireless), black
CZ-RTC6BL	CONEX wired remote controller with Bluetooth®, black
CZ-RTC5B	Wired remote controller with Econavi function
CZ-RWS3 + CZ-RWRT3	Infrared remote controller and receiver

Accessories

PAW-RE2C4-MOD-WH	Room controller for hotel rooms, white
PAW-RE2C4-MOD-BK	Room controller for hotel rooms, black
PAW-RE2D4-WH	Display control for hotel rooms, white
PAW-RE2D4-BK	Display control for hotel rooms, black
CZ-CENSC1	Econavi energy saving sensor

Technical focus

- Low sound levels
- All units just 235 mm high
- Large and wide air distribution
- Easy to install and maintain
- Fresh air knockout

Air distribution is altered depending on the operational mode

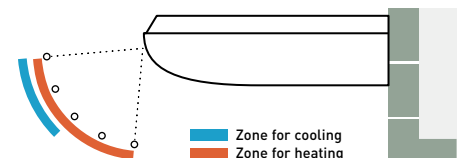

Further comfort improvement with air flow distribution

Horizontal air flow reaches maximum 9,5 m. This is ideal for wide rooms.

The wide air discharge opening expands the air flow to the left and right. The unpleasant feeling caused when the air flow directly hits the human body is prevented by the "Draft prevention position", which changes the swing width, increasing the degree of comfort.

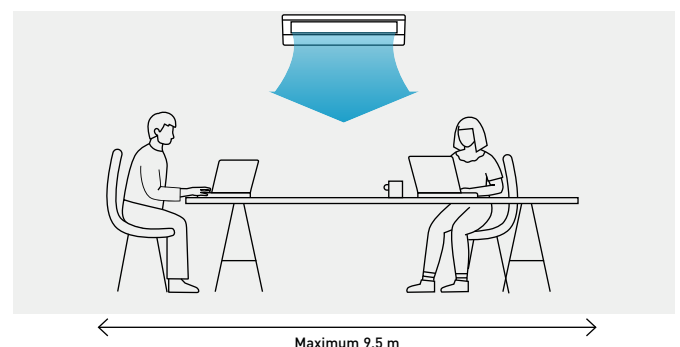

ECONAVI and INTERNET CONTROL: Optional.

K2 type wall-mounted · R32 / R410A

The wall-mounted unit has a stylish smooth panel that looks good and is easy to clean.

The unit is also smaller, lighter and substantially quieter than previous models making it ideal for small offices and other commercial applications.



+ COMPATIBLE WITH ALL PANASONIC CONNECTIVITY SOLUTIONS. FOR DETAILED INFORMATION GO TO THE CONTROL SYSTEMS SECTION

Indoor unit			S-15MK2E5B	S-22MK2E5B	S-28MK2E5B	S-36MK2E5B	S-45MK2E5B	S-56MK2E5B	S-73MK2E5B	S-106MK2E5B
Cooling capacity	kW		1,5	2,2	2,8	3,6	4,5	5,6	7,3	10,6
Input power	W		25,00	25,00	25,00	30,00	30,00	35,00	55,00	80,00
Current	A		0,20	0,21	0,23	0,25	0,32	0,35	0,51	0,70
Heating capacity	kW		1,7	2,5	3,2	4,2	5,0	6,3	8,0	11,4
Input power	W		25,00	25,00	25,00	30,00	30,00	35,00	55,00	80,00
Current	A		0,20	0,21	0,23	0,25	0,32	0,35	0,51	0,70
Fan type			Cross flow	Cross flow	Cross flow	Cross flow	Cross flow	Cross flow	Cross flow	Cross flow
Air flow	Cool (Hi/Med/Lo)	m ³ /min	7,9/7,4/6,5	9,0/7,5/6,5	9,5/8,3/6,5	10,9/9,0/6,5	14,5/12,5/10,0	16,0/14,0/12,0	19,5/17,0/14,0	21,5/18,5/15,0
	Heat (Hi/Med/Lo)	m ³ /min	9,0/7,7/6,8	9,2/8,3/6,8	9,7/8,5/6,8	11,2/9,5/6,8	14,5/12,5/10,0	16,0/14,0/12,0	19,5/17,0/14,0	21,5/18,5/15,0
Sound pressure	Hi/Med/Lo	dB(A)	34/32/29	36/33/29	37/34/29	40/36/29	38/35/33	40/37/35	47/44/40	49/46/42
Sound power	Hi/Med/Lo	dB(A)	49/47/44	51/48/44	52/49/44	55/51/44	53/50/48	55/52/50	62/59/55	64/61/57
Dimension	HxWxD	mm	290x870 x214	290x870 x214	290x870 x214	290x870 x214	302x1120 x236	302x1120 x236	302x1120 x236	302x1120 x236
Net weight	kg		9	9	9	9	13	13	14	14
Piping diameter	Liquid	Inch (mm)	1/4(6,35)	1/4(6,35)	1/4(6,35)	1/4(6,35)	1/4(6,35)	1/4(6,35)	3/8(9,52) ¹⁾	3/8(9,52)
	Gas	Inch (mm)	1/2(12,70)	1/2(12,70)	1/2(12,70)	1/2(12,70)	1/2(12,70)	1/2(12,70)	5/8(15,88) ¹⁾	5/8(15,88)

1) When the piping diameter is (liquid) Ø1/4 (6,35) - (gas) Ø1/2 (12,70), connect the liquid socket tube (Ø1/4 (6,35) - Ø3/8 (9,52)) to the liquid tubing side indoor unit and connect the gas socket tube (Ø1/2 (12,70) - Ø5/8 (15,88)) to the gas tubing side indoor unit.

Accessories

CZ-RTC6W	CONEX wired remote controller (non-wireless), white
CZ-RTC6WBL	CONEX wired remote controller with Bluetooth®, white
CZ-RTC6	CONEX wired remote controller (non-wireless), black
CZ-RTC6BL	CONEX wired remote controller with Bluetooth®, black
CZ-RTC5B	Wired remote controller with Econavi function
CZ-RWS3	Infrared remote controller
PAW-RE2C4-MOD-WH	Room controller for hotel rooms, white

Accessories

PAW-RE2C4-MOD-BK	Room controller for hotel rooms, black
PAW-RE2D4-WH	Display control for hotel rooms, white
PAW-RE2D4-BK	Display control for hotel rooms, black
CZ-CENSC1	Econavi energy saving sensor
CZ-P56SVK2	External valve for model sizes 15 to 56
CZ-P160SVK2	External valve for model sizes 60 to 106
CZ-CGLSC1	Panasonic R32 refrigerant leak detector

Technical focus

- Compact lightweight units for easy installation
- Quiet operation
- Smooth and durable design
- Piping outlet in six directions
- Air distribution is automatically altered depending on the operational mode

Air distribution is automatically altered depending on the operational mode of the unit

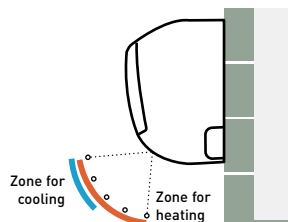

Quiet operation

These units are among the quietest in the industry, making them ideal for hotels and hospitals.

Lighter and smaller units

Compact and lightweight units make for easy installation. When the unit is turned OFF, the flap closes completely to prevent entry of dust into the unit and to keep the equipment clean.

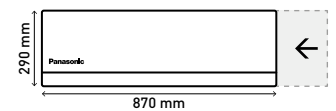

Piping outlet in six directions

Piping outlet is possible in six directions of; right, right rear, right bottom, left, left rear and left bottom, making the installation work more flexible.



External valve (optional)

CZ-P56SVK2 (model sizes 15 to 56).
CZ-P160SVK2 (model sizes 60¹⁾ to 106).

1) When the piping diameter is liquid 1/4(6,35) and gas 1/2(12,70), use CZ-P56SVK2



ECONAVI and INTERNET CONTROL: Optional.

Rating conditions: Cooling indoor 27 °C DB / 19 °C WB. Cooling outdoor 35 °C DB / 24 °C WB. Heating indoor 20 °C DB. Heating outdoor 7 °C DB / 6 °C WB. (DB: Dry Bulb; WB: Wet Bulb). Specifications subject to change without notice. For detailed information about ErP / Energy Labelling, please visit our websites www.aircon.panasonic.eu or www.ptc.panasonic.eu.

G1 type floor console · R410A

The stylish and compact unit profile, also used for residential market range, is easy to integrate into any design of building.

Compact and versatile, this system is capable of being installed in an area with limited space. It is a perfect solution for retrofit, replacing existing radiator panels.



+ COMPATIBLE WITH ALL PANASONIC CONNECTIVITY SOLUTIONS. FOR DETAILED INFORMATION GO TO THE CONTROL SYSTEMS SECTION

+ nanoex™
nanoex™ X as a standard.

Indoor unit		S-22MG1E5N	S-28MG1E5N	S-36MG1E5N	S-45MG1E5N	S-56MG1E5N
Cooling capacity	kW	2,2	2,8	3,6	4,5	5,6
Input power	W	20,00	20,00	22,00	28,00	31,00
Current	A	0,20	0,20	0,23	0,25	0,28
Heating capacity	kW	2,5	3,2	4,2	5,0	6,3
Input power	W	21,00	21,00	23,00	29,00	32,00
Current	A	0,20	0,20	0,24	0,26	0,28
Fan type		Cross flow	Cross flow	Cross flow	Cross flow	Cross flow
nanoex X Generator		Mark 1	Mark 1	Mark 1	Mark 1	Mark 1
Air flow	Cool (Hi/Med/Lo)	m ³ /min	9,2/7,5/6,0	9,2/7,5/6,0	9,7/8,2/6,0	10,5/9,0/6,5
	Heat (Hi/Med/Lo)	m ³ /min	9,7/8,0/6,5	9,7/8,0/6,5	10,2/8,7/6,5	11,0/9,5/7,0
Sound pressure	Hi/Med/Lo	dB(A)	38/34/29	38/34/29	39/35/29	42/37/30
Dimension	H x W x D	mm	600 x 750 x 207	600 x 750 x 207	600 x 750 x 207	600 x 750 x 207
Net weight		kg	14	14	14	14
Piping diameter	Liquid	Inch (mm)	1/4(6,35)	1/4(6,35)	1/4(6,35)	1/4(6,35)
	Gas	Inch (mm)	1/2(12,70)	1/2(12,70)	1/2(12,70)	1/2(12,70)

* Infrared receiver is integrated with the unit as standard.

Accessories	
CZ-RTC6W	CONEX wired remote controller (non-wireless), white
CZ-RTC6WBL	CONEX wired remote controller with Bluetooth®, white
CZ-RTC6	CONEX wired remote controller (non-wireless), black
CZ-RTC6BL	CONEX wired remote controller with Bluetooth®, black
CZ-RTC5B	Wired remote controller with Econavi function
CZ-RWS3*	Infrared remote controller

Accessories	
PAW-RE2C4-MOD-WH	Room controller for hotel rooms, white
PAW-RE2C4-MOD-BK	Room controller for hotel rooms, black
PAW-RE2D4-WH	Display control for hotel rooms, white
PAW-RE2D4-BK	Display control for hotel rooms, black
CZ-CENSC1	Econavi energy saving sensor

1 nanoex™ X: Bringing nature's balance indoors

Panasonic's nanoex™ X technology brings nature's detergent – hydroxyl radicals – indoors to help improve protection 24/7 against several types of pollutants can be inhibited such as certain types of bacteria, viruses, mould, allergens, pollen or hazardous substances.

2 Stylish and simple

- Clean and modern European design with slim depth
- Modern matt white color panel
- Washable air filter

The stylish and compact unit profile, also used for residential market range, is easy to integrate into any design of building.



Dimension:
W x H x D = 750 x 600 x 207 mm

Weight:
14kg

3 Flexible easy installation

Four different mounting styles possible: exposed (floor or wall), semi-recessed and recessed.

Flexible installation with 4 different options.

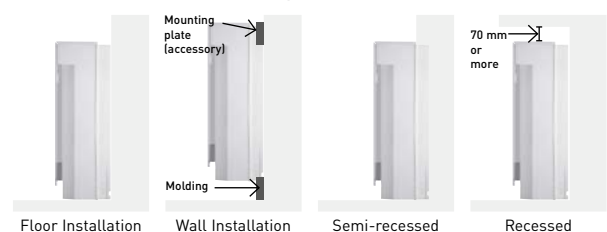

4 Functions for comfort

- Double Air Flow direction to maximize comfort
- Self-cleaning function
- Compatible with Commercial Wi-Fi Adaptor for cloud control

Self-cleaning function.

- Self cleaning function can be pre-scheduled with remote controller, up to a maximum of 90 minutes following cooling / dry operation
- Air flow will not blow directly at occupants during self-cleaning



ECONAVI and INTERNET CONTROL: Optional.

P1 type floor-standing · R410A

The compact floor-standing P1 units are the ideal solution for providing perimeter air conditioning.



+ COMPATIBLE WITH ALL PANASONIC CONNECTIVITY SOLUTIONS. FOR DETAILED INFORMATION GO TO THE CONTROL SYSTEMS SECTION

Indoor unit			S-22MP1E5	S-28MP1E5	S-36MP1E5	S-45MP1E5	S-56MP1E5	S-71MP1E5
Cooling capacity		kW	2,2	2,8	3,6	4,5	5,6	7,1
Input power		W	56,00	56,00	85,00	126,00	126,00	160,00
Current		A	0,25	0,25	0,38	0,56	0,56	0,72
Heating capacity		kW	2,5	3,2	4,2	5,0	6,3	8,0
Input power		W	40,00	40,00	70,00	91,00	91,00	120,00
Current		A	0,18	0,18	0,31	0,41	0,41	0,54
Fan type			Sirocco fan	Sirocco fan	Sirocco fan	Sirocco fan	Sirocco fan	Sirocco fan
Air flow	Hi/Med/Lo	m ³ /min	7,0/6,0/5,0	7,0/6,0/5,0	9,0/7,0/6,0	12,0/9,0/8,0	15,0/13,0/11,0	17,0/14,0/12,0
External static pressure		Pa	15	15	15	15	15	15
Sound pressure	Hi/Med/Lo	dB(A)	33/30/28	33/30/28	39/35/29	38/35/31	39/36/31	41/38/35
Dimension	HxWxD	mm	615x1065x230	615x1065x230	615x1065x230	615x1380x230	615x1380x230	615x1380x230
Net weight		kg	29	29	29	39	39	39
Piping diameter	Liquid	Inch (mm)	1/4(6,35)	1/4(6,35)	1/4(6,35)	1/4(6,35)	1/4(6,35)	3/8(9,52)
	Gas	Inch (mm)	1/2(12,70)	1/2(12,70)	1/2(12,70)	1/2(12,70)	1/2(12,70)	5/8(15,88)

Accessories

CZ-RTC6W	CONEX wired remote controller (non-wireless), white
CZ-RTC6WBL	CONEX wired remote controller with Bluetooth®, white
CZ-RTC6	CONEX wired remote controller (non-wireless), black
CZ-RTC6BL	CONEX wired remote controller with Bluetooth®, black
CZ-RTC5B	Wired remote controller with Econavi function

Accessories

CZ-RWS3 + CZ-RWRC3	Infrared remote controller and receiver
PAW-RE2C4-MOD-WH	Room controller for hotel rooms, white
PAW-RE2C4-MOD-BK	Room controller for hotel rooms, black
PAW-RE2D4-WH	Display control for hotel rooms, white
PAW-RE2D4-BK	Display control for hotel rooms, black

Technical focus

- Pipes can be connected to either side of the unit from the bottom or rear
- Easy to install
- Front panel opens fully for easy maintenance
- Removable air discharge grille gives flexible airflow
- Room for condensate pump

Effective perimeter handling

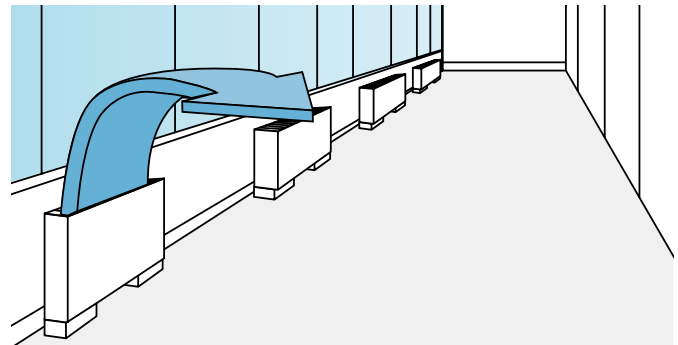

INTERNET CONTROL: Optional.

Rating conditions: Cooling indoor 27 °C DB / 19 °C WB. Cooling outdoor 35 °C DB / 24 °C WB. Heating indoor 20 °C DB. Heating outdoor 7 °C DB / 6 °C WB. (DB: Dry Bulb; WB: Wet Bulb). Specifications subject to change without notice. For detailed information about ErP / Energy Labelling, please visit our websites www.aircon.panasonic.eu or www.ptc.panasonic.eu.

R1 type concealed floor-standing · R410A

At just 229 mm deep, the R1 unit can be easily concealed in perimeter areas to provide powerful and effective air conditioning.



+ COMPATIBLE WITH ALL PANASONIC CONNECTIVITY SOLUTIONS. FOR DETAILED INFORMATION GO TO THE CONTROL SYSTEMS SECTION

Indoor unit		S-22MR1E5	S-28MR1E5	S-36MR1E5	S-45MR1E5	S-56MR1E5	S-71MR1E5	
Cooling capacity	kW	2,2	2,8	3,6	4,5	5,6	7,1	
Input power	W	56,00	56,00	85,00	126,00	126,00	160,00	
Current	A	0,25	0,25	0,38	0,56	0,56	0,72	
Heating capacity	kW	2,5	3,2	4,2	5,0	6,3	8,0	
Input power	W	40,00	40,00	70,00	91,00	91,00	120,00	
Current	A	0,18	0,18	0,31	0,41	0,41	0,54	
Fan type		Sirocco fan	Sirocco fan	Sirocco fan	Sirocco fan	Sirocco fan	Sirocco fan	
Air flow	Hi/Med/Lo	m ³ /min	7,0/6,0/5,0	7,0/6,0/5,0	9,0/7,0/6,0	12,0/9,0/8,0	15,0/13,0/11,0	17,0/14,0/12,0
External static pressure		Pa	15	15	15	15	15	
Sound pressure	Hi/Med/Lo	dB(A)	33/30/28	33/30/28	39/35/29	38/35/31	39/36/31	41/38/35
Dimension	HxWxD	mm	616x904x229	616x904x229	616x904x229	616x1219x229	616x1219x229	616x1219x229
Net weight		kg	21	21	21	28	28	28
Piping diameter	Liquid	Inch (mm)	1/4(6,35)	1/4(6,35)	1/4(6,35)	1/4(6,35)	1/4(6,35)	3/8(9,52)
	Gas	Inch (mm)	1/2(12,70)	1/2(12,70)	1/2(12,70)	1/2(12,70)	1/2(12,70)	5/8(15,88)

Accessories

CZ-RTC6W	CONEX wired remote controller (non-wireless), white
CZ-RTC6WBL	CONEX wired remote controller with Bluetooth®, white
CZ-RTC6	CONEX wired remote controller (non-wireless), black
CZ-RTC6BL	CONEX wired remote controller with Bluetooth®, black
CZ-RTC5B	Wired remote controller with Econavi function

Accessories

CZ-RWS3 + CZ-RWRC3	Infrared remote controller and receiver
PAW-RE2C4-MOD-WH	Room controller for hotel rooms, white
PAW-RE2C4-MOD-BK	Room controller for hotel rooms, black
PAW-RE2D4-WH	Display control for hotel rooms, white
PAW-RE2D4-BK	Display control for hotel rooms, black

Technical focus

- Chassis unit for discreet installation
- Complete with removable filters
- Pipes can be connected to either side of the unit from the bottom or rear
- Easy to install

Perimeter air conditioning with high interior quality

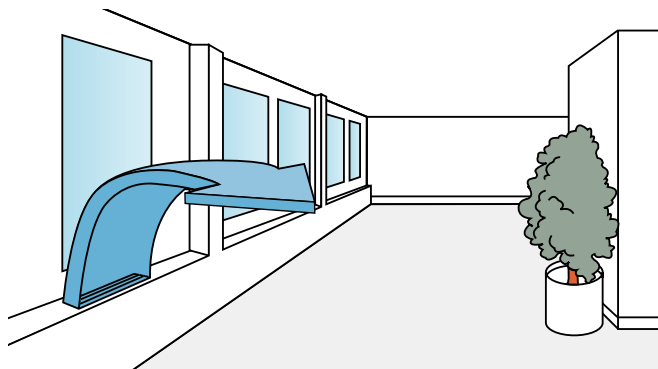

INTERNET CONTROL: Optional.

Hydrokit for ECOi, water at 45 °C · R410A

Connect the Hydrokit to your VRF system, together with other indoor units.

Total system performs high energy efficiency through heat recovering operation, and it gives an advantage for sustainability related assessment methods, such as BREEAM in UK.



+ COMPATIBLE WITH ALL PANASONIC CONNECTIVITY SOLUTIONS. FOR DETAILED INFORMATION GO TO THE CONTROL SYSTEMS SECTION

Indoor unit				S-80MW1E5	S-125MW1E5
Power supply	Voltage	V		230	230
	Phase			Single phase	Single phase
	Frequency	Hz		50	50
Cooling capacity			kW	8,0	12,5
Heating capacity			kW	9,0	14,0
Maximum temperature			°C	-45 / -65 ¹⁾	-45 / -65 ¹⁾
Dimension	H x W x D		mm	892 x 502 x 353	892 x 502 x 353
Water pipe connector			Inch	R 1 ¼	R 1 ¼
Water pump (built-in)				DC motor (A class)	DC motor (A class)
Water flow rate	Cool	L/min		22,90	35,80
	Heat	L/min		25,80	40,10
Piping diameter	Liquid	Inch (mm)		3/8 (9,52)	3/8 (9,52)
	Gas	Inch (mm)		5/8 (15,88)	5/8 (15,88)
	Drain	mm		15 ~ 17 (inner size)	15 ~ 17 (inner size)
Operation range	Cool	Ambient	°C	+10 ~ +43	+10 ~ +43
		Water	°C	+5 ~ +20	+5 ~ +20
	Heat	Ambient	°C	-20 ~ +43	-20 ~ +43
		Water	°C	+25 ~ +45	+25 ~ +45
Connectable system			3-Pipe (heat recovery type) VRF System (system capable up to 48 HP)		
Maximum Indoor ratio (connectable hydrokit module capacity ratio)			Total indoor unit + Hydrokit capacity: up to 130% (** ~ **% vs total outdoor unit capacity)		

1) Maximum 45 °C by refrigerant circuit (heat pump cycle), over 45 °C is provided by electric heater operation.

Accessories

CZ-RTC5B Wired remote controller with Econavi function

Basic principle and advantage.

Hydrokit module provides hot water by using waste heat that is recovered from standard air-conditioning indoor unit in cooling mode.

Technical focus

- Only with 3-Pipe ECOi EX MF3 Series outdoor units
- Remote controller CZ-RTC5B common use with DX coil indoor units PACi and ECOi

Hydrokit control function / CZ-RTC5B

- CZ-RTC5B can be used for hydrokit and also normal indoor unit. CZ-RTC5B checks the type of connected unit and switches between hydrokit and air conditioner display automatically

- Hydrokit mode (tank or air conditioning mode) is set during initial startup

Overview: hydromodule in VRF system

- Multiple hydromodule connection in same circuit is available
- The mode of each module can be individually set from either hot water or space heating / cooling (once set the units cannot operate in another mode, resetting will be required)
- 3-Pipe control solenoid valve kit is necessary for each indoor unit and hydromodule

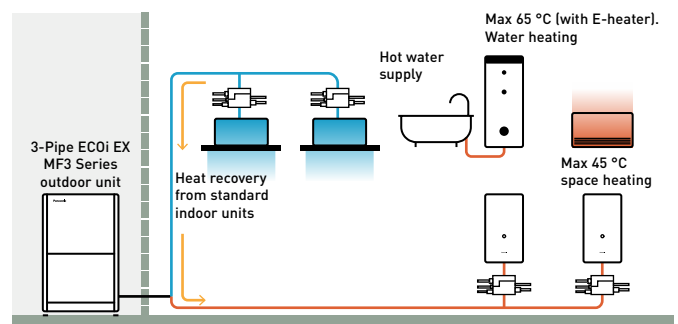

* Cold water also available.

NEW AHU connection kit MAH4M for ECOi 2-Pipe

Space-saving compact casing.
Direct Modbus communication without the need for an additional interface.
Accurate control with a pressure transducer.

New
2024



Built-in controller.



PAW-P+100MAH4M			6 HP	12 HP	16 HP
Cooling capacity	Nominal	kW	16,0	33,5	45,0
Heating capacity	Nominal	kW	17,0	37,5	50,0
Air flow	Min / Max	m ³ /h	1800/4400	2000/10000	3500/12000
Dimension	HxWxD	mm	300x400x150	300x400x150	300x400x150
Weight		kg	11	11	11
Pipe length range		m	10 ~ 100	10 ~ 100	10 ~ 100
Elevation difference (in / out)		m	10	10	10
Piping diameter ≤ 90 m	Liquid	Inch (mm)	3/8 (9,52)	1/2 (12,70)	1/2 (12,70)
	Gas	Inch (mm)	5/8 (15,88)	1 (25,40)	1 1/8 (28,57)
Piping diameter > 90 m ¹⁾	Liquid	Inch (mm)	—	5/8 (15,88)	5/8 (15,88)
	Gas	Inch (mm)	—	1 1/8 (28,57)	1 1/4 (31,75)

1) For R410A models only.

AHU connection kit / system combination						
Cooling capacity	Mini VRF			2-Pipe VRF	AHU connection kit	EEV pack
	Mini ECOi LZ2 Series (R32)		Mini ECOi LE2 Series (R410A)	ECOi EX ME2 Series		
6 HP	16,0 kW	U-5LZ2E5(8) U-6LZ2E5(8)	U-5LE2E5(8) U-6LE2E5(8)	—	PAW-P+100MAH4M	PAW-P+116EEVPACK
12 HP	33,5 kW	U-8LZ2E8 U-10LZ2E8	U-8LE1E8 U-10LE1E8	U-8ME2E8 U-10ME2E8 U-12ME2E8	PAW-P+100MAH4M	PAW-P+133EEVPACK
16 HP	45,0 kW	—	—	U-14ME2E8 U-16ME2E8	PAW-P+100MAH4M	PAW-P+145EEVPACK

Accessories	
PAW-P+102SENSPACK	AHU connection kit sensor pack 1 (2 pcs of SENSOR PT1000 HT IP67 -50/250 CABLE 6 m PCK)
PAW-P+116EEVPACK	EEV pack 1 (1 pc of expansion valve ≤ 16 kW [R410A / R32] and 1 pc of UNIPOLAR stator)
PAW-P+133EEVPACK	EEV pack 2 (1 pc of expansion valve ≤ 33 kW [R410A / R32] and 1 pc of UNIPOLAR stator)

Accessories	
PAW-P+145EEVPACK	EEV pack 3 (1 pc of expansion valve ≤ 45 kW [R410A / R32] and 1 pc of UNIPOLAR stator)
PAW-P+100PGNEPACK	Remote control pack (1 pc of PGNE 132 x 64 mm, mounting panel and 1 pc of cable L= 1,5 m, telephone connectors)

Technical focus

- Maximum capacity / system: 16 HP (45 kW*)
- Selectable expansion valve packs depending on the capacity
- DC 12 V outlet available without optional interface
- Maximum elevation difference indoor/outdoor unit: 10 m
- Elevation difference (indoor unit / indoor unit): 4 m
- In / out connection capacity ratio: 50~100%
- Maximum number of AHU connection kits: 1 unit
- Outdoor temperature range in heating: -20 ~ +15 °C
- Available temperature range for the suction air at AHU connection kit: cool: +18 ~ +32 °C / heat: +16 ~ +30 °C
- The system's set temperature can be selected either as the default setting discharge air temperature (supply room temperature) or the suction air set temperature (or room return air temperature)
- Accurate control with a pressure transducer
- Direct Modbus communication with a built-in Modbus S-Link interface
- Various technical parameters available with Modbus
- SG ready fulfilled. Demand input can be set Thermostat OFF or 40 - 200% by the user
- Defrost operation signal, compressor status ON / OFF output
- Display an error message concerning drain water overflow

- Connectable with S-Link system. Special care for electrical noise may be necessary depending on the on-site system
- Fan control signal output to manage the air flow (ON / OFF)
- Alarm status monitoring output

* Nominal cooling capacity.

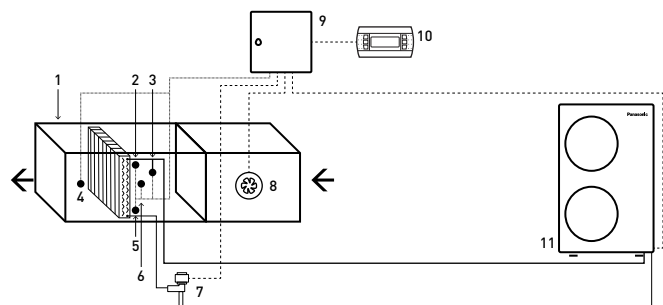

System and regulations. System overview.

- AHU Unit equipment (field supplied)
- Thermistor for gas pipe (E3)
- Pressure transducer
- Thermistor for discharge air (BL)
- Thermistor for liquid pipe (E1)
- Thermistor for suction air (TA)
- Expansion valve (accessorie part)
- Fan (field supplied)
- AHU connection kit controller box
- Optional remote controller
- Outdoor unit Mini ECOi and 2-Pipe ECOi EX

AHU connection kit MAH3M for ECOi and ECO G

Available with ECOi and ECO G Series.
 CONEX Bluetooth® version [CZ-RTC6BL] is built-in.
 0-10 V demand control.



CONEX
 CONEX Bluetooth®
 control built-in.
 CZ-RTC6BL



Reference	PAW-	5 HP	10 HP	20 HP	30 HP	40 HP	50 HP	60 HP	70 HP	80 HP	
		160MAH3M	280MAH3M	560MAH3M	280MAH3M 560MAH3M	560MAH3M	560MAH3M 280MAH3M	560MAH3M 560MAH3M	560MAH3M 560MAH3M	560MAH3M 280MAH3M	560MAH3M 560MAH3M
Cooling capacity	kW	14,0	28,0	56,0	84,0	112,0	140,0	168,0	196,0	224,0	
Heating capacity	kW	16,0	31,5	63,0	95,0	127,0	155,0	189,0	219,0	252,0	
Air flow	Cool Min/Max m³/h	2598/1140	4998/3498	10002/7002	15000/10500	19998/13998	24996/17496	30000/21000	24000/35000	28000/40000	
Bypass factor recommended		0,9	0,9	0,9	0,9	0,9	0,9	0,9	0,9	0,9	
Dimension	HxWxD mm	500x400 x150	500x400 x150	500x400 x150	500x400 x150	500x400 x150	500x400 x150	500x400 x150	500x400 x150	500x400 x150	
Net weight	kg	11,5	11,5	11,5	11,5	11,5	11,5	11,5	11,5	11,5	
Pipe length range	m	10~100	10~100	10~100	10~100	10~100	10~100	10~100	10~100	10~100	
Elevation difference (in / out)	Max m	10	10	10	10	10	10	10	10	10	
Piping diameter	Liquid Inch (mm)	3/8(9,52)	3/8(9,52)	5/8(15,88)	3/4(19,05)	3/4(19,05)	3/4(19,05)	3/4(19,05)	7/8(22,22)	7/8(22,22)	
	Gas Inch (mm)	5/8(15,88)	7/8(22,22)	1 1/8(28,58)	1 1/4(31,75)	1 1/2(38,15)	1 1/2(38,15)	1 1/2(38,15)	1 5/8(41,28)	1 3/4(44,45)	
Intake temperature of AHU connection kit	Cool Min~Max °C DB	+18~+32	+18~+32	+18~+32	+18~+32	+18~+32	+18~+32	+18~+32	+18~+32	+18~+32	
	Cool Min~Max °C WB	+13~+23	+13~+23	+13~+23	+13~+23	+13~+23	+13~+23	+13~+23	+13~+23	+13~+23	
	Heat Min~Max °C	+16~+30	+16~+30	+16~+30	+16~+30	+16~+30	+16~+30	+16~+30	+16~+30	+16~+30	
Ambient temperature of outdoor unit	Cool Min~Max °C	-10~+43	-10~+43	-10~+43	-10~+43	-10~+43	-10~+43	-10~+43	-10~+43	-10~+43	
	Heat Min~Max °C	-20~+15	-20~+15	-20~+15	-20~+15	-20~+15	-20~+15	-20~+15	-20~+15	-20~+15	

AHU connection kit / system combination

Capacity	ECOi Series			AHU kit				Capacity	ECO G Series	AHU kit
5 HP 16 kW	All ECOi			160MAH3M	—	—	—	5 HP 16 kW	All ECO G	160MAH3M
10 HP 28 kW	U-10ME2E8	—	—	280MAH3M	—	—	—	10 HP 28 kW	All ECO G	280MAH3M
20 HP 56 kW	U-20ME2E8	—	—	560MAH3M	—	—	—	20 HP 56 kW	U-20GE3E5	560MAH3M
30 HP 84 kW	U-16ME2E8	U-14ME2E8	—	560MAH3M	280MAH3M	—	—			
40 HP 112 kW	U-20ME2E8	U-20ME2E8	—	560MAH3M	560MAH3M	—	—			
50 HP 140 kW	U-18ME2E8	U-16ME2E8	U-16ME2E8	560MAH3M	560MAH3M	280MAH3M	—			
60 HP 168 kW	U-20ME2E8	U-20ME2E8	U-20ME2E8	560MAH3M	560MAH3M	560MAH3M	—			
70 HP 196 kW	U-20ME2E8	U-20ME2E8	U-20ME2E8	560MAH3M	560MAH3M	560MAH3M	280MAH3M			
80 HP 224 kW	U-20ME2E8	U-20ME2E8	U-20ME2E8	560MAH3M	560MAH3M	560MAH3M	560MAH3M			

Technical focus

- Maximum capacity / system: 80 HP (224 kW)
- Maximum piping length: 100 m (120 m equivalent)
- Elevation difference (indoor unit / indoor unit): 4 m
- In / out capacity ratio: 50~100%
- Maximum number of AHU connection kits: 4 units*
- Outdoor temperature range in heating: -20 ~ +15 °C
- Available temperature range for the suction air at AHU connection kit: cool: +18 ~ +32 °C / heat: +16 ~ +30 °C
- The systems is controlled by the suction air (or room return air) temperature (same as standard indoor unit)
- The discharge air temperature is also controlled to prevent too-low air discharge in cooling or too-high air discharge in heating (in case of VRF)
- Demand control (forcible thermostat-OFF control by operating current)
- Defrost operation signal, Thermo-ON / OFF states output
- Drain pump control (drain pump and the float switch to be supplied in local)
- External target temperature setting via indoor / outdoor signal interface is available with CZ-CAPBC2 (Ex. 0-10 V)
- Demand control 40% to 120% (5% steps) by 0-10 V input signal
- Connectable with S-Link system. Special care for electrical noise may be necessary depending on the on-site system

- Fan control signal from the PCB can be used to control the air flow (high / mid / low and LL for Th-OFF). Need to change the fan control circuit wiring at field

* To be simultaneous operation controlled by one remote controller sensor.

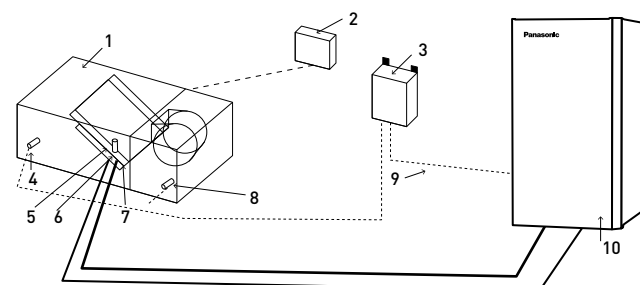

System and regulations. System overview.

- 1 | AHU Unit equipment (field supplied)
- 2 | AHU Unit system controller (field supplied)
- 3 | AHU connection kit controller box (with control PCB)
- 4 | Thermistor for discharge air
- 5 | Electronic expansion valve
- 6 | Thermistor for gas pipe (E3)
- 7 | Thermistor for liquid pipe (E1)
- 8 | Thermistor for suction air
- 9 | Inter-unit wiring
- 10 | ECOi or ECOi G outdoor unit

Optional controller.

Timer remote controller.
 CZ-RTC5B.



Energy recovery ventilation

Indoor air quality (IAQ) is a key consideration for any business owner looking to create a healthy and comfortable environment. An energy recovery ventilator (ERV) provides balanced, energy-efficient ventilation by transferring heat and moisture between incoming fresh filtered air and outgoing stale air. In the winter, an ERV keeps heat and moisture inside the building. During hot, humid summer months, it maintains cool, dry indoor air.



Advanced ERV ZY Series.

- Extended 9 model line-up including 2000 m³/h model
- DC motors
- ESP up to 150 Pa
- F7 grade filter built-in as a standard
- New intuitive remote controller
- BMS integration with RS485



ERV ZDY Series.

- Simple 5 line-up
- AC motor
- A nonwoven cloth filter
- Simple wired remote controller with black panel



Advanced energy recovery ventilation - ZY Series



Rated flow rate			150 m³/h	250 m³/h	350 m³/h	500 m³/h	650 m³/h	800 m³/h	1000 m³/h	1500 m³/h	2000 m³/h
Indoor unit			FV-15ZY1G	FV-25ZY1G	FV-35ZY1G	FV-50ZY1G	FV-65ZY1G	FV-80ZY1G	FV-1KZY1G	FV-1HZY1G	FV-2KZY1G
Power supply	Voltage	V	220 - 240	220 - 240	220 - 240	220 - 240	220 - 240	220 - 240	220 - 240	220 - 240	220 - 240
	Phase		Single phase	Single phase	Single phase	Single phase	Single phase	Single phase	Single phase	Single phase	Single phase
	Frequency	Hz	50	50	50	50	50	50	50	50	50
Motor type			DC	DC	DC	DC	DC	DC	DC	DC	DC
ERV											
Air flow	Max	m³/h	150	250	350	500	650	800	1000	1500	2000
External static pressure	Max	Pa	100	120	140	130	150	150	150	130	130
Sound power ²⁾	Max	dB(A)	37	38	39	43	45	45	46	49	51
Input power	Max	W	76 - 84	106 - 117	141 - 155,5	180 - 198	420 - 462	470 - 517	550 - 605	940 - 1034	1100 - 1210
Heat exchange efficiency ³⁾											
Cooling	Max	%	68,0	69,0	71,0	65,0	64,0	63,0	65,0	63,0	65,0
Heating	Max	%	83,0	82,0	83,0	81,0	82,0	83,0	82,0	83,0	82,0
Enthalpy exchange efficiency											
Cooling	Max	%	66,0	66,0	67,0	62,5	62,5	63,5	63,0	63,5	63,0
Heating	Max	%	76,0	74,0	75,0	73,0	72,0	73,0	74,0	73,0	74,0
Adapter diameter		mm	100	150	150	200	200	250	250	250	250
Dimension	H x W x D	mm	289 x 610 x 860	289 x 735 x 860	331 x 874 x 968	331 x 1016 x 968	404 x 954 x 1008	404 x 1004 x 1224	404 x 1231 x 1224	808 x 1004 x 1224	808 x 1231 x 1224
Net weight		kg	23	27	37	40	48	60	64	119	142

1) Different dimensions depending on models. 2) Measurement of noise 1,5 m below the center of the main unit (anechoic chamber). 3) Heat exchange efficiency measurement standard JIS B 8628 (2003). * JIS B 8628 (2017) is used in the measurement environment. * A remote controller is included.

Accessories

FV-FP15ZY1G	Replacement high efficiency filter for FV-15ZY1G
FV-FP25ZY1G	Replacement high efficiency filter for FV-25ZY1G
FV-FP35ZY1G	Replacement high efficiency filter for FV-35ZY1G
FV-FP50ZY1G	Replacement high efficiency filter for FV-50ZY1G

Accessories

FV-FP65ZY1G	Replacement high efficiency filter for FV-65ZY1G
FV-FP80ZY1G	Replacement high efficiency filter for FV-80ZY1G and FV-1HZY1G*
FV-FP1KZY1G	Replacement high efficiency filter for FV-1KZY1G and FV-2KZY1G*

* 2 sets of filters required for those models.

Energy recovery ventilation - ZDY Series

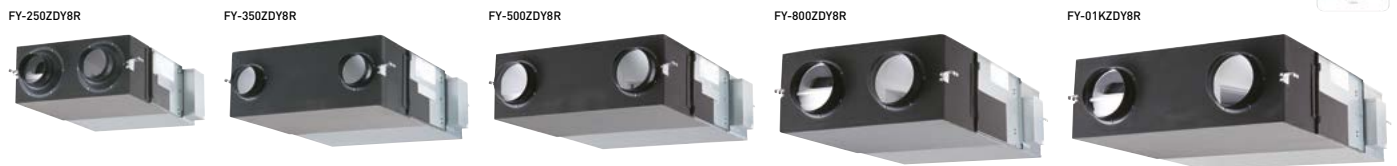

Rated flow rate			250 m³/h			350 m³/h			500 m³/h			800 m³/h			1000 m³/h		
Indoor unit			FY-250ZDY8R			FY-350ZDY8R			FY-500ZDY8R			FY-800ZDY8R			FY-01KZDY8R		
Power supply	Voltage	V	220 - 240			220 - 240			220 - 240			220 - 240			220 - 240		
	Phase		Single phase			Single phase			Single phase			Single phase			Single phase		
	Frequency	Hz	50			50			50			50			50		
Notch			Extra high	High	Low	Extra high	High	Low	Extra high	High	Low	Extra high	High	Low	Extra high	High	Low
Input power		W	112,0 - 128,0	108,0 - 123,0	87,0 - 96,0	182,0 - 190,0	178,0 - 185,0	175,0 - 168,0	263,0 - 289,0	204,0 - 225,0	165,0 - 185,0	387,0 - 418,0	360,0 - 378,0	293,0 - 295,0	437,0 - 464,0	416,0 - 432,0	301,0 - 311,0
Air flow		m³/h	250	250	190	350	350	240	500	500	440	800	800	630	1000	1000	700
External static pressure		Pa	105	95	45	140	60	45	120	60	35	140	110	55	105	80	75
Sound power	Heat exchange	dB(A)	30,0 - 31,5	29,5 - 30,5	23,5 - 26,5	32,5 - 33,0	30,5 - 31,0	22,5 - 25,5	36,5 - 37,5	34,5 - 35,5	31,0 - 32,5	37,0 - 37,5	36,5 - 37,0	33,5 - 34,5	37,5 - 38,5	37,0 - 37,5	33,5 - 34,5
	Normal	dB(A)	30,0 - 31,5	29,5 - 30,5	23,5 - 26,5	32,5 - 33,0	30,5 - 31,0	22,5 - 25,5	37,5 - 38,5	37,0 - 38,0	31,0 - 32,5	37,0 - 37,5	36,5 - 37,0	33,5 - 34,5	39,5 - 40,5	39,0 - 39,5	35,5 - 36,5
Temperature exchange efficiency		%	75	75	77	75	75	78	75	75	76	75	75	76	75	75	79
Dimension	H x W x D	mm	270 x 599 x 882			317 x 804 x 1050			317 x 904 x 1090			388 x 884 x 1322			388 x 1134 x 1322		
Net weight		kg	29			49			57			71			83		

The noise level was measured within an acoustic chamber. Due to installation arrangement and surfaces within the space, actual noise levels may increase. The input, the current and the exchange efficiency are values relevant to the indicated air flows. The noise level is measured 1,5 m below the centre of the unit. The temperature exchange efficiency is an average of both cooling and heating operation.

NEW energy recovery ventilation with DX coil - HRPT Series · R32 / R410A

- Dual flow ventilation with EC fan, featuring high efficiency heat recovery (>85% η)
- 2 types of polypropylene heat exchanger (high efficiency and sensible) with counter-current flows and integrated bypass as standard
- Modbus connection available

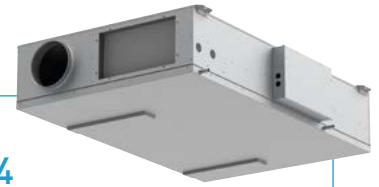

New 2024

+ COMPATIBLE WITH ALL PANASONIC CONNECTIVITY SOLUTIONS. FOR DETAILED INFORMATION GO TO THE CONTROL SYSTEMS SECTION

Indoor unit with high-efficiency heat exchanger			PAW-HRPT40HX	PAW-HRPT80HX	PAW-HRPT120HX	PAW-HRPT160HX	PAW-HRPT200HX					
Power supply	Voltage	V	230	230	230	230	380					
	Phase		Single phase	Single phase	Single phase	Single phase	Three phase					
	Frequency	Hz	50	50	50	50	50					
Heat recovery ventilation ¹⁾			Cooling	Heating	Cooling	Heating	Cooling	Heating	Cooling	Heating		
Temperature efficiency	%		60,9	49,5	59,2	47,6	60,3	48,8	61,0	49,6	59,2	47,6
Enthalpy efficiency	%		75,7	51,6	73,1	48,9	73,6	50,7	74,3	50,8	73	48,8
Weight	kg		70		120		135		150		180	

Indoor unit with sensible heat exchanger			PAW-HRPT40	PAW-HRPT80	PAW-HRPT120	PAW-HRPT160	PAW-HRPT200					
Power supply	Voltage	V	230	230	230	230	380					
	Phase		Single phase	Single phase	Single phase	Single phase	Three phase					
	Frequency	Hz	50	50	50	50	50					
Heat recovery ventilation ¹⁾			Cooling	Heating	Cooling	Heating	Cooling	Heating	Cooling	Heating		
Temperature efficiency	%		86,1	86,6	84,3	84,7	82,9	83,5	83,9	84,2	81,3	82,0
Weight	kg		67		117		132		147		177	

Common data												
DX coil			Cooling	Heating	Cooling	Heating	Cooling	Heating	Cooling	Heating	Cooling	Heating
Total / Sensible capacity	kW		2,5	3,0	5,0	6,0	7,0	8,1	10,0	12,5	12,5	14,0
Maximum input current	A		1,5		2,2		4,1		4,4		3,3	
Sound pressure @1 m / @3 m	dB(A)		41 / 35		51 / 43		42 / 36		49 / 41		57 / 49	
Air flow	High	m ³ /h	500		800		1500		1700		2450	
External static pressure	High	Pa	150		150		150		150		150	
Dimension	H x W x D	mm	283 x 975 x 1400		408 x 1180 x 1720		408 x 1580 x 1720		408 x 1980 x 1720		408 x 1980 x 1720	
Piping diameter	Liquid	Inch (mm)	1/4 (6,35)		3/8 (9,52)		3/8 (9,52)		3/8 (9,52)		3/8 (9,52)	
	Gas	Inch (mm)	1/2 (12,70)		5/8 (15,88)		5/8 (15,88)		5/8 (15,88)		5/8 (15,88)	

1) Data refers to the following conditions (UNI EN 13141-7): nominal air flow, external air 5 °C with 72% r. / expelled air 25 °C with 28% r. * Image is for PAW-HRPT40.

Accessories	
CZ-RTC6W	CONEX wired remote controller (non-wireless), white
CZ-RTC6WBL	CONEX wired remote controller with Bluetooth®, white
CZ-RTC6	CONEX wired remote controller (non-wireless), black
CZ-RTC6BL	CONEX wired remote controller with Bluetooth®, black
CZ-RTC5B	Wired remote controller with Econavi function

Accessories	
PAW-RE2C4-MOD-WH	Room controller for hotel rooms, white
PAW-RE2C4-MOD-BK	Room controller for hotel rooms, black
PAW-RE2D4-WH	Display control for hotel rooms, white
PAW-RE2D4-BK	Display control for hotel rooms, black

Technical focus

- Dual flow ventilation with EC fan, featuring high efficiency heat recovery (>85% η)
- 5 model line-up is available with air flow rates of 500, 800, 1200, 1600 and 2000 m³/h
- 2 types of polypropylene heat exchanger (high efficiency and sensible) with counter-current flows and integrated bypass as standard
- Automatic defrosting of the exchanger
- Low consumption and EC motors with electronic speed control ensure high useful static pressure for circular inlet connection to air ducts
- Wide ambient temperature range up to +50 °C and down to -15 °C
- Modbus connection available



Interconnection to outdoor / indoor units

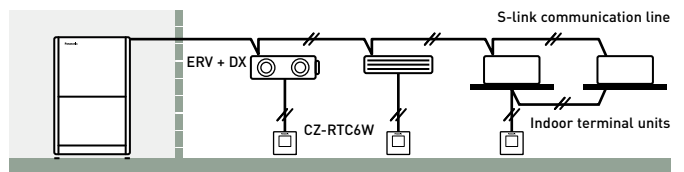

Aeraulic performance

EC motors with electronic speed control ensure high values of effective static pressure for ducting.

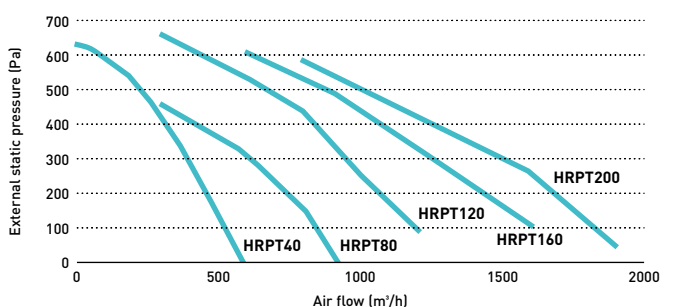

Heat recovery with DX coil - ZDX Series - R410A

Motorised heat recovery by-pass device automatically controlled to use fresh air free-cooling when convenient.



+ COMPATIBLE WITH ALL PANASONIC CONNECTIVITY SOLUTIONS. FOR DETAILED INFORMATION GO TO THE CONTROL SYSTEMS SECTION

Indoor unit			PAW-500ZDX3N	PAW-800ZDX3N	PAW-01KZDX3N			
Power supply	Voltage	V	230	230	230			
	Phase		Single phase	Single phase	Single phase			
	Frequency	Hz	50	50	50			
Air flow		m ³ /min	8,3	13,3	16,7			
External static pressure ¹⁾		Pa	90	120	115			
Maximum current	Total full load	A	0,6	1,4	2,1			
Input power		W	150	320	390			
Sound pressure ²⁾		dB(A)	39	42	43			
Piping diameter	Liquid	Inch (mm)	1/4 (6,35)	1/4 (6,35)	1/4 (6,35)			
	Gas	Inch (mm)	1/2 (12,70)	1/2 (12,70)	1/2 (12,70)			
Heat recovery			Cooling	Heating	Cooling	Heating	Cooling	Heating
Temperature efficiency	%		76	76	76	76	76	76
Enthalpy efficiency	%		63	67	63	65	60	62
Saved power summer mode or winter mode*	kW		1,70	4,30 (4,80)	2,50	6,50 (7,30)	3,20	8,20 (9,00)
DX coil								
Total / Sensible capacity	kW		3,00/2,10	2,50/2,70	5,10/3,50	4,40/4,80	5,80/4,10	5,20/6,70
OFF temperature	°C		15,9	28,0 (27,3)	15,5	29,6 (29,0)	16,2	28,5 (27,8)
OFF relative humidity	%		90	16 (15)	90	14 (13)	89	15 (14)

Nominal summer conditions: Outside air: 32 °C DB, RH 50%. Ambient air: 26 °C DB, RH 50%. Nominal winter conditions: Outside air: -5 °C DB, RH 80%. Ambient air: 20 °C DB, RH 50%. Cooling mode air inlet condition: 28,5 °C DB, RH 50%; evaporating temperature 7 °C. Heating mode air inlet condition: 13 °C DB, RH 40% (11 °C DB, RH 45%); condensating temperature 40 °C. DB: Dry Bulb; RH: Relative Humidity. 1) Referred to the nominal air flow after filter and plate heat exchanger. 2) Sound pressure level calculated at 1 m far from: ducted supply exhaust air ducted return - first air intake / service side, at normal condition. * Tentative data.

Accessories	
CZ-RTC6W	CONEX wired remote controller (non-wireless), white
CZ-RTC6WBL	CONEX wired remote controller with Bluetooth®, white
CZ-RTC6	CONEX wired remote controller (non-wireless), black
CZ-RTC6BL	CONEX wired remote controller with Bluetooth®, black
CZ-RTC5B	Wired remote controller with Econavi function

Accessories	
PAW-RE2C4-MOD-WH	Room controller for hotel rooms, white
PAW-RE2C4-MOD-BK	Room controller for hotel rooms, black
PAW-RE2D4-WH	Display control for hotel rooms, white
PAW-RE2D4-BK	Display control for hotel rooms, black

Technical focus

- Galvanized steel self-supporting panels, internally and externally insulated
- High efficiency static cross-flow heat recovery, made by membrane with high moisture permeability, good air tightness, excellent tear, and aging resistance, structure consisting of flat and corrugated plates. Total heat exchange with temperature efficiency up to 76% and enthalpy efficiency up to 67%, also at high level during summer season
- ISO16890 ePm2,5 95% (F9 EN 779) efficiency class filter with synthetic cleanable media and COARSE 50% (G3 EN 779) pre-filter ON fresh air, COARSE 50% filter on return air intake
- Removable side panel to access filters and heat recovery in the event of scheduled maintenance
- Low consumption, low noise, high efficiency direct driven fans

- Supply section complete with DX coil (R410A) fitted with solenoid control valve, freon filter, contact temperature sensors on liquid and gas line, NTC sensors upstream and downstream of air flow
- Built-in electric box equipped with PCB to control internal fan speed and to interconnect outdoor / indoor units
- Duct connection by circular plastic collars

Balanced ventilation

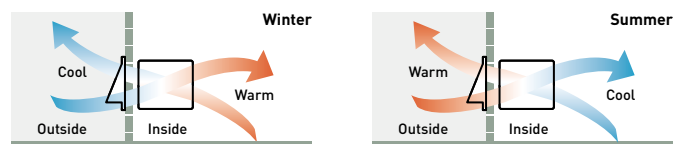

Interconnection to outdoor / indoor units

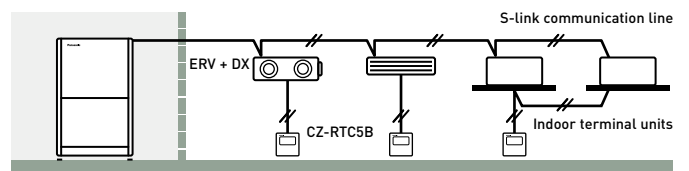

INTERNET CONTROL: Optional.

Rating conditions: Cooling indoor 27 °C DB / 19 °C WB. Cooling outdoor 35 °C DB / 24 °C WB. Heating indoor 20 °C DB. Heating outdoor 7 °C DB / 6 °C WB. (DB: Dry Bulb; WB: Wet Bulb). Specifications subject to change without notice. For detailed information about ErP / Energy Labelling, please visit our websites www.aircon.panasonic.eu or www.ptc.panasonic.eu.

Air curtain with DX coil, connected to VRF systems

Comfort: Easy redirection of air flow by means of manual deflector.

Ease of use: Speed selector (high and low) on the unit itself.

Easy installation and maintenance: Easy installation / Compact dimensions improve installation and positioning / Easy cleaning of grid without opening of the unit.



Outdoor unit capacity			4 HP	4 HP	5 HP	8 HP
Air outlet height 2,7 m			PAW-10EAIRC-LS	PAW-15EAIRC-LS	PAW-20EAIRC-LS	PAW-25EAIRC-LS
Cooling capacity ¹⁾	Max	kW	6,1	9,7	13,0	17,0
Heating capacity ²⁾	Max	kW	7,9	12,0	15,0	19,0
Air flow	High	m ³ /h	1800	2700	3600	4500
Heat Exchanger	Volume	L	1,67	2,85	3,94	5,03
Electric consumption fan	230 V / 50 Hz	kW	0,30	0,50	0,60	0,80
Current	230 V / 50 Hz	A	2,10	3,10	4,10	5,10
Sound pressure ³⁾	Max	dB(A)	65	66	67	69
Air outlet height 3,0 m			PAW-10EAIRC-HS	PAW-15EAIRC-HS	PAW-20EAIRC-HS	PAW-25EAIRC-HS
Cooling capacity ¹⁾	Max	kW	9,1	13,0	19,5	23,7
Heating capacity ²⁾	Max	kW	11,8	15,8	23,6	27,6
Air flow	High	m ³ /h	2700	3600	5400	6300
Heat Exchanger	Volume	L	1,67	2,85	3,94	5,12
Electric consumption fan	230 V / 50 Hz	kW	0,75	1,00	1,50	1,75
Current	230 V / 50 Hz	A	4,10	5,50	8,20	9,60
Sound pressure ³⁾	Max	dB(A)	66	67	68	68
Common data						
Dimension ⁴⁾	HxWxD	mm	260 (+140) x 1000 x 460	260 (+140) x 1500 x 460	260 (+140) x 2000 x 460	260 (+140) x 2500 x 460
Net weight	Air outlet height 2,7 m	kg	50	65	80	95
	Air outlet height 3,0 m	kg	55	65	85	110
Fan type			EC	EC	EC	EC
Piping diameter	Liquid / Gas	Inch (mm)	3/8 (9,52) / 5/8 (15,88)	3/8 (9,52) / 3/4 (19,05)	3/8 (9,52) / 7/8 (22,22)	3/8 (9,52) / 7/8 (22,22)
Door width		m	1,0	1,5	2,0	2,5
Refrigerant			R32 / R410A	R32 / R410A	R32 / R410A	R32 / R410A

LS / VRF outdoor combination

Operation until	40 °C	35 °C	30 °C
PAW-1EAIRC-LS	U-4	U-4	U-4
PAW-15EAIRC-LS	U-6	U-5	U-4
PAW-20EAIRC-LS	U-8	U-6	U-4
PAW-25EAIRC-LS	U-8	U-8	U-5

HS / VRF outdoor combination

Operation until	40 °C	35 °C	30 °C
PAW-10EAIRC-HS	U-6	U-5	U-4
PAW-15EAIRC-HS	U-8	U-6	U-4
PAW-20EAIRC-HS	U-8	U-8	U-8
PAW-25EAIRC-HS	U-12	U-10	U-8

1) Cooling capacity DX coil, air temperature in / out +27 / +18 °C, R32 and R410. 2) Heating capacity condenser, air temperature in / out +20 / +33 °C, R32 and R410. In the case of lower outdoor temperatures, an outdoor model with higher capacity may be necessary. 3) Measured in distance up to 5,0 m, direction factor 2, absorbing surfaces 200 m², Min / Max air flow. 4) 140 mm is the height of an electrical box if it is installed on the top. * Also compatible with ECO G Series (GE3 and GF3) and Hybrid Serie.

Technical focus

- Compatible with R32 and R410A refrigerant
- Save up to 40% energy costs by use of the integrated EC fan technology (higher efficiency than conventional AC fan, soft start and longer motor duration)
- 4 length of air curtain LS and HS are available 1,0, 1,5, 2,0 and 2,5 m
- Installation height up to 3,0 m
- Outlet grilles can be adjusted in five positions, to suite different indoor and installation requirements
- Control with Panasonic remote control systems (optional)
- Direct integration to BMS via optional Panasonic interfaces
- Drip tray included in all DX air curtains
- Drain pump included

Internet control

An app added to your tablet or smartphone or via the Internet allows you to control and manage the system remotely. There is also the option to integrate into existing BMS systems by using other Panasonic interfaces.

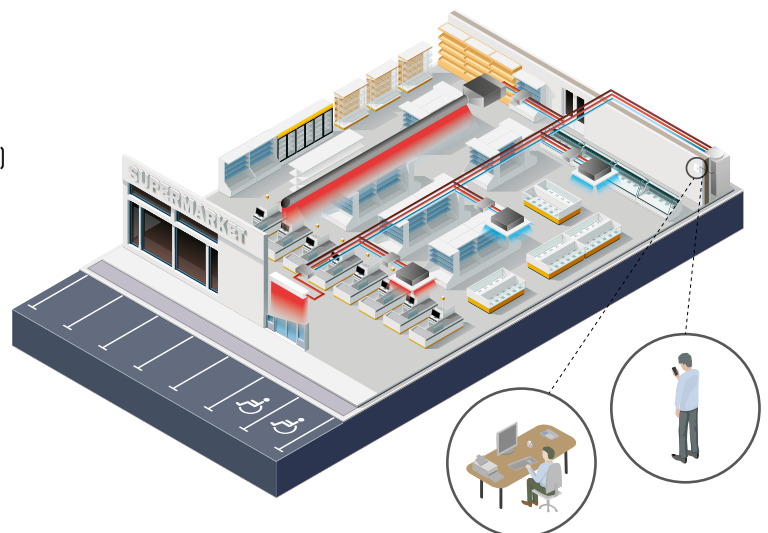

Ceiling mounted air-e nanoe X Generator

- nanoe™ X technology
(Generator Mark 1: 4,8 trillion hydroxyl radicals/sec)
- Silent operation. Whisper quiet at 25,5 dB(A)*
- Low power consumption 4 W
- Easy installation
- Compact and modern design

* 230 V.

air-e™



Model	FV-15CSD1G					
Power supply	Voltage	V	220	230	240	
	Frequency	Hz	50	50	50	
Air flow	m³/h		15	16	17	
	CFM		8,8	9,4	10,0	
Consumption	W		4	4	4	
Sound pressure	dB(A)		23,5	25,5	27,0	
Net weight	kg			1,1		

* The value of air volume, power consumption and noise are specified at static pressure 0 Pa. The value of air volume is the mean value and a tolerance of +-10% is allowed. The value of noise level is a weighted average sound pressure level, the mean value is measured by Panasonic. A tolerance of +3 dB/-7 dB is allowed. The noise is measure at 1 m apart from the left, the front and below of the tested product. Conditions of generating nanoe™ X: room temperature: about 5 °C ~ 40 °C (dew point temperature more than 2 °C), relative humidity: about 30% ~ 85%. nanoe™ X is generated using the air in the room, and its amount is subject to the temperature and humidity in the air.

One device is suitable for around 20 m² (with a ceiling height 3 m)

Ex. 3 air-e devices are required for the room size 60 m².

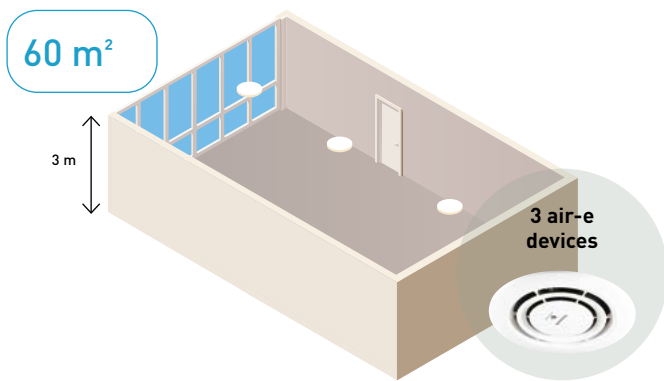

Concentration simulator is ready

See how nanoe™ X fills space.



The air-e is a stand alone device which is an easy and simple choice to improve indoor air quality. It can be easily installed to various commercial projects including refurbishments.

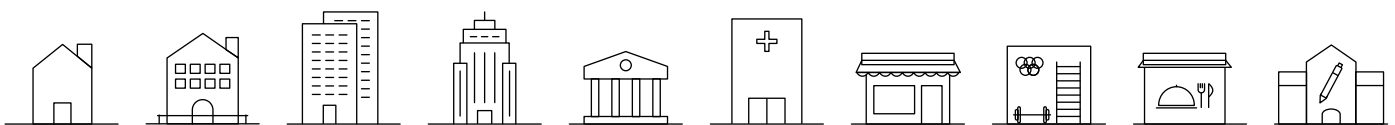

The tested effects of nanoe™ X

Bacteria and viruses.

SARS-CoV-2: 99,9% % inhibited ¹⁾

Influenza virus H1N1 subtype: 99,9 % inhibited ²⁾

Odour.

nanoe X Generator can reduce cigarette smoke odour intensity by 2,4 levels in 12 minutes.

- 1) Novel coronavirus [SARS-CoV-2] > [Test organization] Texcell [France] [Test subject] Adhered novel coronavirus [SARS-CoV-2] [Test volume] 45 L enclosed box [Test result] Inhibited 99,9% in 2 hours [Test report] 1140-01 A1.
- 2) Adhered virus [Influenza virus H1N1 subtype] > [Test organization] Kitasato Research Center for Environmental Science [Test subject] Influenza virus [H1N1 subtype] [Test volume] 1000 L enclosed box [Test result] Inhibited 99,9% in 2 hours [Test report] 21_0084_1.
- 3) Deodorisation effect for adhering odour [cigarette smoke] > [Test organization] Panasonic Product Analysis Center [Test subject] Adhered cigarette smoke odour [Test volume] Approx. 24 m³ laboratory [Test result] Odour intensity reduced 2,4 levels in 0,2 hours [Test report] 4AA33-160615-N04.

Performance of nanoe™ X might differ in real life environment and is only expected in the same room as where the unit is placed. The nanoe™ X performance varies depending on the room size, environment and usage and it may take several hours to reach the full effect. nanoe™ X is not a medical device.

Deodorisation effect for adhering odour (cigarette smoke) ³⁾

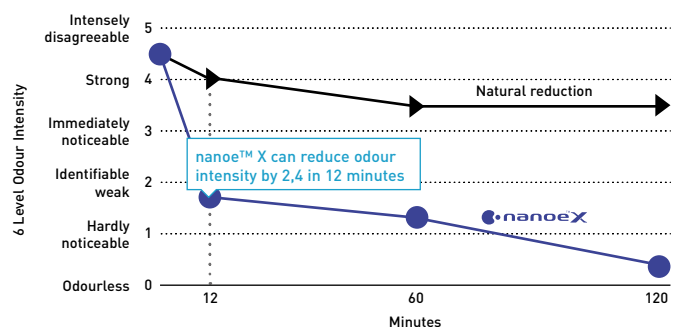

For further details and validation data, please refer to the following website.



Fan coils units

+ MORE FAN COIL OPTIONS IN CHILLERS SECTION

A large range of fan coil units dedicated to energy savings, comfort, flexibility and quality.



Energy savings and comfort

Low consumption solutions.

- High efficiency fan motor
- High level of energy performance

Silence.

- Optimised fan speed staging
- Reinforced acoustic insulation
- Profiled air diffusers

Flexibility and quality

Many factory-mounted options.

- Control
- Valve
- Air diffusion
- Condensate drain pump ...

Products fully customisable to satisfy your requirements.

- Choice of service side for hydraulic and electrical connections
- Version with or without cabinet ...

Controllers with sophisticated designs, provide a user friendly interface while enabling an easy and low cost integration to building management systems.

Optional wired remote controller for AC fan, 2-pipe and 4-pipe application.



PAW-FC-RC1

Optional wired remote controller for AC fan 2-pipe application.



PAW-FC-903AC



PAW-FC-907AC

Optional wired remote controller for EC fan, 2-pipe and 4-pipe application.



PAW-FC-903EC



PAW-FC-907EC

Smart fan coils



Built-in advanced thermostat.

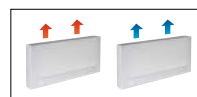

		PAW-AAIR-200-2	PAW-AAIR-700-2	PAW-AAIR-900-2	PAW-AAIR-1100-2
Total cooling capacity	Lo/Med/Hi kW	0,3/0,5/0,6	0,6/0,9/1,5	0,8/1,6/2,1	0,9/1,8/2,5
Sensible capacity	Lo/Med/Hi kW	0,2/0,4/0,6	0,5/0,9/1,3	0,7/1,3/1,9	0,9/1,6/2,3
Water flow	Lo/Med/Hi kg/h	51,1/89,4/106,3	96,0/155,2/251,1	140,8/267,2/365,7	158,1/300,3/423,6
Water pressure drop	Lo/Med/Hi kPa	3,3/5,7/6,1	1,1/2,1/4,2	1,5/5,8/10,3	1,3/5,0/10,6
Inlet water temperature	°C	10	10	10	10
Outlet water temperature	°C	15	15	15	15
Inlet air temperature	°C	27	27	27	27
Outlet air temperature	Lo/Med/Hi °C	12,8/13,2/14,9	14,6/14,8/14,0	15,8/14,6/14,4	18,1/15,2/14,7
Relative humidity of inlet air	%	47	47	47	47
Total heating capacity	Lo/Med/Hi kW	0,2/0,4/0,5	0,4/0,8/1,2	0,6/1,2/1,6	0,8/1,4/2,1
Water flow	Lo/Med/Hi kg/h	38,4/70,5/92,8	72,7/139,2/201,6	114,0/204,2/284,5	138,3/243,2/356,7
Water pressure drop	Lo/Med/Hi kPa	1,0/2,3/3,0	0,5/1,5/3,1	1,0/3,3/6,6	1,1/3,1/7,3
Inlet water temperature	°C	35	35	35	35
Outlet water temperature	°C	30	30	30	30
Inlet air temperature	°C	19	19	19	19
Outlet air temperature	Lo/Med/Hi °C	33,5/33,3/30,9	30,1/31,4/31,8	30,1/31,1/31,2	26,6/29,5/30,5
Air flow	Lo/Med/Hi m ³ /min	0,9/1,9/2,7	2,6/4,2/5,3	4,1/6,1/7,7	6,2/7,6/9,6
Maximum input power	Lo/Med/Hi W	7,0/9,0/13,0	14,0/18,0/22,0	16,0/20,0/24,0	18,0/22,0/26,5
Sound pressure	Lo/Med/Hi dB(A)	24/33/39	25/34/40	25/34/42	26/35/43
Dimension (HxWxD)	mm	579 x 735 x 129	579 x 935 x 129	579 x 1135 x 129	579 x 1335 x 129
Net weight	kg	17	20	23	26
3 Ways valve included		Yes	Yes	Yes	Yes
Touch screen thermostat		Yes	Yes	Yes	Yes

* Smart fan coils is produced by Innova.

Accessories

PAW-AAIR-LEGS-1 Set of 2 legs to protect water pipes

Accessories

PAW-AAIR-RHCABLE Motor connection cable for units with right hand hydraulic connections

Stylish floor-standing fan coils with advanced controller

The slimline of Smart fan coils delivers high efficiency climate control.

With a depth of just under 130 mm they are at the cutting edge of the market. Blending easily into the home, Smart fan coil's elegant design and product refinements are clear to see in every detail.

Exceptional ventilation efficiency means the motor uses considerably less energy (low wattage). The fan speed is continuously modulated by the temperature controller with proportional integral logic, with undoubted advantages for regulating the temperature and humidity in summer mode.

Technical focus

- 4 operation modes (auto, silent, night-time and maximum ventilation speed)
- Exclusive design
- Extremely compact (only 129 mm deep)
- Cooling and dehumidification functions possible (drain is needed)
- 3-way valve included (no overflow valve needed on the installation if more than 3 units installed)
- Touch screen thermostat

With standard cast radiators.

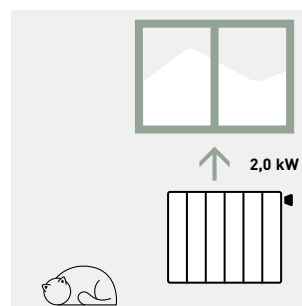

Water at 65 °C needed.

With Smart fan coil.

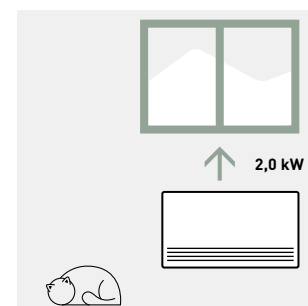

Water at 35 °C needed.

All temperature curves and capacity are available on www.panasonicproclub.com

PRO Club



Fan coil comfort AC fan

Fan coil floor and ceiling units with cooling and heating.

Cooling capacity: 0,6 to 6,9 kW.

Heating capacity: 0,6 to 7,4 kW.



Optional controller.
WRC remote control.



Optional controller.
SRC - mini BMS
controller.



Optional controller.
Electronic controller
TControl POD glass.



Optional controller.
Electronic controller
TControl EASY 3S.



Optional controller.
Wired remote
controller with
touch control.
PAW-FC-907AC



Optional controller.
Wired remote
controller.
PAW-FC-903AC



Optional controller.
Advanced wired
remote controller.
PAW-FC-RC1

SEE PAGE 516 FOR MORE DETAILS ABOUT FAN COIL CONTROLLERS

Operating limits

Entering water temperature (without glycol).

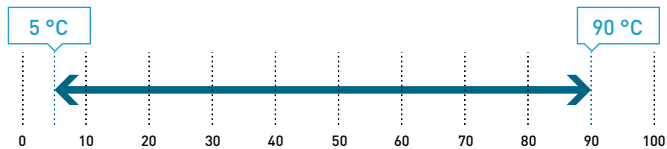

Indoor air temperature.

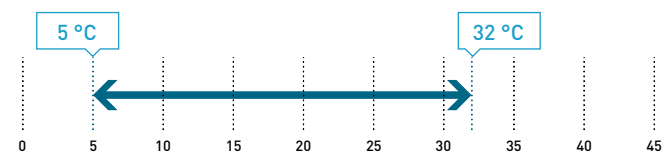

The range at a glance

- Versions: 2-pipes, 2-pipes + electric heater and 4-pipes
- 7 sizes
- 5-speed AC fan - standard factory set speeds: S1,S3,S5
- Air flow from 94 to 1064 m³/h
- Configuration: universal installation units (vertical or horizontal) with or without cabinet
- Left or right water connections
- Many air inlet/outlet configurations
- G2 air filter (G3 as an option)

Advantages

- Silent units
- New casing design for an increased robustness
- Harmonious and aesthetic RAL 9003 painted cabinet
- Valves, condensate drain pan and drain pump factory mounted
- 100% factory tested

Accessories and options

2 way or 3 way valves

4-pipes kit (additional coil)

Circuit breakers

Drain pump

Electric heaters (from 500 W to 2500 W)

Feet with/without grid

Fuse holders

G3 filter

Horizontal or vertical drain guard (with valve)

Many air inlet/outlet configurations

Mechanical sensor for automatic change over

Modbus communication board for Plogic

MRC/WRC/BRC: remote controls for Plogic

Other speeds configuration (standard factory set speeds: S1,S3,S5)

SRC - mini BMS controller

Suspension kit

Plogic controller (other electromechanical or electronic control systems also available)

TControl EASY 3S and TControl POD glass controllers (other electromechanical or electronic control systems also available)

AC SELECT.

Smart and user-friendly the new air conditioning selection program: <https://acselect.panasonic.eu/>



Technical features

Fan coil comfort AC fan		P-FC10		P-FC20		P-FC30		P-FC40		P-FC50		P-FC60		P-FC70		
		S1/S3/S5 ¹⁾		S1/S3/S5 ¹⁾		S1/S3/S5 ¹⁾		S1/S3/S5 ¹⁾		S1/S3/S5 ¹⁾		S1/S3/S5 ¹⁾		S1/S3/S5 ¹⁾		
2-pipes																
Total cooling capacity ²⁾	kW	0,66/1,00/1,45	0,61/0,96/1,38	0,95/1,88/2,37	1,14/2,28/3,02	1,71/3,16/4,64	2,57/4,33/5,53	3,24/5,84/6,91								
Sensible capacity ²⁾	kW	0,48/0,77/1,05	0,43/0,70/1,02	0,78/1,44/1,80	0,83/1,66/2,23	1,24/2,23/3,27	1,81/3,14/4,25	2,26/4,11/4,85								
Water flow ²⁾	l/h	114/172/250	105/165/238	164/324/408	196/393/520	295/544/799	443/746/953	558/1006/1190								
Water pressure drop ²⁾³⁾	kPa	9,17/19,5/39,1	2,65/4,62/7,43	5,8/17,6/26,3	5,0/15,6/25,6	7,5/22,8/47,1	12,6/33,9/54,4	4,4/13,9/19,4								
Heating capacity ⁴⁾	kW	0,63/1,18/1,71	0,63/1,03/1,53	1,00/1,86/2,49	1,14/2,28/3,18	1,79/3,47/4,81	2,45/4,22/5,63	3,45/6,27/7,41								
Water flow ⁴⁾	l/h	109/203/295	109/177/264	172/320/429	196/393/548	308/598/829	422/727/970	594/1080/1276								
Water pressure drop ³⁾⁴⁾	kPa	5,9/17,3/33,8	2,76/5,06/8,54	5,8/16,2/27,0	5,0/15,6/28,1	6,1/20,7/38,5	18,6/52,4/91,4	4,9/16,0/22,3								
4-pipes																
Total cooling capacity ²⁾	kW	0,63/0,88/1,24	0,87/1,34/1,73	0,91/1,80/2,28	0,98/2,14/2,85	1,57/2,88/4,13	2,60/4,39/5,61	3,17/5,62/6,58								
Sensible capacity ²⁾	kW	0,46/0,67/0,91	0,65/1,02/1,36	0,75/1,39/1,74	0,71/1,57/2,10	1,14/2,04/2,92	1,82/3,18/4,28	2,21/3,96/4,62								
Water flow ²⁾	l/h	109/152/214	150/231/298	157/310/393	169/369/491	270/496/711	448/756/966	546/968/1133								
Water pressure drop ²⁾³⁾	kPa	7,6/13,9/26,3	2,33/4,44/6,64	2,8/8,6/13,1	5,8/20,5/33,6	3,9/11,6/22,8	10,2/27,7/44,5	5,3/16,2/22,1								
Heating capacity ⁵⁾	kW	0,63/1,00/1,41	1,00/1,40/1,68	1,28/1,81/2,13	1,22/2,21/2,85	2,01/3,19/4,08	2,71/4,24/5,33	3,65/5,00/5,90								
Water flow ⁵⁾	l/h	54/86/121	86,1/121/145	110/156/183	105/190/245	173/275/351	233/365/459	314/431/508								
Water pressure drop ³⁾⁵⁾	kPa	1,2/2,1/3,3	1,15/2,2/3,12	2,8/4,7/6,1	5,1/13,9/21,8	5,7/12,5/19,4	11,6/24,8/37	35,4/60,7/81,2								
Sound levels																
Sound power	2-pipes	dB(A)	33/40/49	31/43/50	30/45/52	30/44/51	34/43/56	38/51/58	43/56/61							
	4-pipes	dB(A)	33/40/49	31/43/50	30/45/52	30/44/51	34/46/56	38/51/58	43/56/61							
Sound pressure ⁶⁾	2-pipes	dB(A)	24/31/40	22/34/41	21/36/43	21/35/42	25/37/47	29/42/49	34/47/52							
	4-pipes	dB(A)	24/31/40	22/34/41	21/36/43	21/35/42	25/37/47	29/42/49	34/47/52							
NR ⁶⁾	2-pipes		19/26/35	17/29/36	16/31/38	16/30/37	20/32/42	24/37/44	29/42/47							
	4-pipes		19/26/35	17/29/36	16/31/38	16/30/37	20/32/42	24/37/44	29/42/47							
Ventilation																
Number of fans			1	1	1	2	2	2	2							
Air flow	2-pipes	m ³ /h	94/190/283	68/104/196	138/274/390	173/357/499	253/486/716	350/640/933	480/893/1064							
	4-pipes	m ³ /h	95/168/253	89/161/241	132/263/369	148/335/467	242/466/671	334/614/885	470/859/1012							
Filter			G2	G2	G2	G2	G2	G2	G2							
Electrical data																
Power supply	Voltage	V	230	230	230	230	230	230	230							
	Phase		Single phase	Single phase	Single phase	Single phase	Single phase	Single phase	Single phase							
	Frequency	Hz	50/60	50/60	50/60	50/60	50/60	50/60	50/60	50/60						
Consumption	2-pipes	W	13/24/36	13/18/31	16/37/45	15/37/56	28/55/72	37/75/105	53/100/147							
	4-pipes	W	13/24/36	11/18/28	16/37/44	15/37/55	28/54/70	37/74/104	53/99/145							
Electric heater		W	500	500	500/1000	1250	1250/2500	1250/2500	1250/2500							
Water connections																
Connection type			Gas female threaded	Gas female threaded	Gas female threaded	Gas female threaded	Gas female threaded	Gas female threaded	Gas female threaded							
2 or 4-pipes	Cooling	Inch	½	½	½	½	½	½	½							
4-pipes	Heating	Inch	½	½	½	½	½	½	½							
Dimension																
With cabinet - without feet	LxWxH	mm	766x225x477	766x225x477	951x225x477	1136x225x477	1321x225x477	1506x225x477	1319x225x575							
Without cabinet	LxWxH	mm	570x220x430	570x220x430	753x220x430	938x220x430	1122x220x430	1307x220x430	1121x220x530							
Weight																
With cabinet	2-pipes	kg	19	19	22	27	30	35	35							
	4-pipes	kg	20	20	23	29	32	37	37							
Without cabinet	2-pipes	kg	13	13	15	20	22	26	27							
	4-pipes	kg	14	14	16	22	24	28	29							

1) Fan standard factory set speeds. 2) According to Eurovent standard. Air: 27 °C DB/19 °C WB, chilled water: 7 °C/12 °C. 3) Pressure loss by corresponding nominal flow. 4) According to Eurovent standard. Air: 20 °C, hot water: 45 °C/40 °C. 5) According to Eurovent standard. Air: 20 °C, hot water: 65 °C/55 °C. 6) Informative data, considering an hypothetical sound attenuation of the room and installation of 9 dB(A).



Fan coil wall AC fan

Fan coil wall-mounted units with cooling and heating.

Cooling capacity: 1,0 to 4,0 kW.

Heating capacity: 1,4 to 4,5 kW.



Optional controller.
WRC remote control.



Optional controller.
SRC - mini BMS
controller.



Optional controller.
Electronic controller
TControl POD glass.



Optional controller.
Electronic controller
TControl EASY 3S.



Optional controller.
Wired remote
controller with
touch control.
PAW-FC-907AC



Optional controller.
Wired remote
controller.
PAW-FC-903AC



Optional controller.
Advanced wired
remote controller.
PAW-FC-RC1

+ SEE PAGE 516 FOR MORE DETAILS ABOUT FAN COIL CONTROLLERS

Operating limits

Entering water temperature (without glycol).

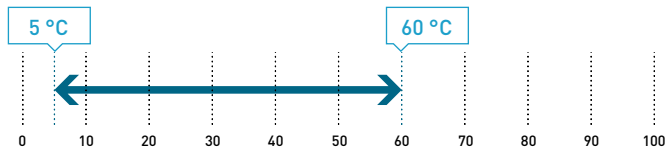

Indoor air temperature.

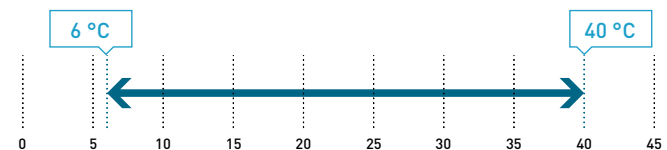

AC SELECT.

Smart and user-friendly the new air conditioning selection program: <https://acselect.panasonic.eu/>



The range at a glance

- Versions (2-pipes): infrared without valve (IR SV), infrared with valve (IR AV) and terminal block without valve (TB SV)
- 4 sizes
- 3-speed AC fan
- Air flow from 280 to 850 m³/h
- G1 cleanable air filter

Advantages

- Reversible
- Aesthetic design
- Light for easy installation
- Silent units
- Very easy servicing through a removable front panel
- Cleanable synthetic-type air filter

Accessories and options

2 way or 3 way valves

Modbus communication board for Plogic

SRC - mini BMS controller

Plogic controller (other electromechanical or electronic control systems also available)

TControl EASY 3S and TControl POD glass controllers (other electromechanical or electronic control systems also available)

WRC: wall-mounted remote control for Plogic

Technical features

Fan coil wall AC fan		P-FW07		P-FW09		P-FW18		P-FW22		
		S2/S3/S4 ¹⁾		S2/S3/S4 ¹⁾		S2/S3/S4 ¹⁾		S2/S3/S4 ¹⁾		
2-pipes, without valve										
Total cooling capacity ²⁾	kW	1,00/1,34/1,69		1,58/1,79/2,50		2,78/3,05/3,60		2,93/3,29/4,00		
Sensible capacity ²⁾	kW	0,72/0,97/1,20		1,21/1,37/1,87		2,12/2,39/2,74		2,28/2,62/3,11		
Water flow ²⁾	l/h	172/231/291		270/308/431		479/525/620		505/565/687		
Water pressure drop ²⁾	kPa	18,6/24,9/31,4		18,5/21,4/31,0		34,6/40,0/52,3		37,2/42,8/54,9		
Heating capacity ³⁾	W	1,42/1,62/1,72		1,68/1,92/2,80		2,99/3,30/4,10		3,18/3,63/4,50		
Water flow ³⁾	l/h	245/279/296		289/331/482		515/568/706		548/625/775		
Water pressure drop ³⁾	kPa	17,6/23,4/26,5		21,4/23,5/28,6		39,9/46,3/64,7		41,7/55,0/85,8		
Sound levels										
Sound power	dB(A)	45/49/51		40/43/52		47/50/54		50/55/60		
Sound pressure ⁴⁾	dB(A)	30/33/35		32/36/40		39/41/43		39/43/48		
NR ⁴⁾	dB(A)	32/36/38		34/39/44		40/43/46		43/46/50		
Ventilation										
Number of fans		1		1		1		1		
Air flow	m ³ /h	282/321/360		367/413/551		532/592/680		617/709/850		
Filter		G1		G1		G1		G1		
Electrical data										
Power supply	Voltage	V	230		230		230		230	
	Phase		Single phase		Single phase		Single phase		Single phase	
	Frequency	Hz	50		50		50		50	
Consumption	Cooling	W	39/42/62		30/33/40		44/48/53		50/55/69	
	Heating	W	39/42/62		27/30/50		42/45/60		46/51/66	
Water connections										
Connection type		Gas female threaded		Gas female threaded		Gas female threaded		Gas female threaded		
Connections	Inch	½		½		½		½		
Dimension and weight										
Dimension	L x W x H	mm 845 x 180 x 275		mm 845 x 180 x 275		mm 940 x 200 x 298		mm 940 x 200 x 298		
Weight	kg	11		11		13		13		
Fan coil wall AC fan		P-FW09				P-FW22				
		S2/S3/S4 ¹⁾				S2/S3/S4 ¹⁾				
2-pipes, with valve										
Total cooling capacity ²⁾	kW	1,11/1,25/1,40				2,32/2,68/3,10				
Sensible capacity ²⁾	kW	0,91/1,08/1,25				1,68/1,98/2,28				
Water flow ²⁾	l/h	191/215/241				400/460/532				
Water pressure drop ²⁾	kPa	14,9/16,8/18,8				42,4/50,8/61,5				
Heating capacity ³⁾	W	1,29/1,61/2,00				2,51/2,75/3,30				
Water flow ³⁾	l/h	222/277/344				432/474/568				
Water pressure drop ³⁾	kPa	16,1/21,3/28,2				45,8/48,6/54,1				
Sound levels										
Sound power	dB(A)	44/50/54				53/57/60				
Sound pressure ⁴⁾	dB(A)	32/36/40				39/43/48				
NR ⁴⁾	dB(A)	27/31/37				34/37/41				
Ventilation										
Number of fans		1				1				
Air flow	m ³ /h	150/250/400				290/400/600				
Filter		G1				G1				
Electrical data										
Power supply	Voltage	V	230				230			
	Phase		Single phase				Single phase			
	Frequency	Hz	50				50			
Consumption	Cooling	W	35/38/43				50/58/69			
	Heating	W	30/33/43				50/58/69			
Water connections										
Connection type		Gas female threaded				Gas female threaded				
Connections	Inch	½				½				
Dimension and weight										
Dimension	L x W x H	mm 845 x 180 x 275				mm 940 x 200 x 298				
Weight	kg	11				13				

1) Fan standard factory set speeds. 2) According to Eurovent standard. Air: 27 °C DB/19 °C WB, chilled water: 7 °C/12 °C. 3) According to Eurovent standard. Air: 20 °C, hot water: 45 °C/40 °C. 4) Informative data, considering an hypothetical sound attenuation of the room and installation of 9 dB(A).



ErP compliant following COMMISSION REGULATION (EU) 2016/2281.

Accessories and control

Distribution joint kits







2-Pipe ME2 for outdoor units (up to 68,0 kW). ----- CZ-P680PH2BM	2-Pipe ME2 for outdoor units (from 68,0 kW to 168,0 kW). ----- CZ-P1350PH2BM	2-Pipe ME2 and Mini ECOi for indoor units (up to 22,4 kW*). ----- CZ-P224BK2BM
2-Pipe ME2 for indoor units (from 22,4 kW to 68,0 kW*). ----- CZ-P680BK2BM	2-Pipe ME2 for indoor units (from 68,0 kW to 168,0 kW*). ----- CZ-P1350BK2BM	3-Pipe MF3 for outdoor units (up to 68,0 kW). ----- CZ-P680PJ2BM
3-Pipe MF3 for outdoor units (from 68,0 kW to 135,0 kW). ----- CZ-P1350PJ2BM	3-Pipe MF3 for indoor units (up to 22,4 kW). ----- CZ-P224BH2BM	3-Pipe MF3 for indoor units (from 22,4 kW to 68,0 kW). ----- CZ-P680BH2BM
3-Pipe MF3 for indoor units (up to 68,0 kW). ----- CZ-P1350BH2BM	2-Pipe ME2 header pipe. ----- CZ-P4HP4C2BM	3-Pipe MF3 header pipe. ----- CZ-P4HP3C2BM

* In case the total capacity of indoor units connected after distribution exceeds the total capacity of the outdoor units, select the distribution piping size for the total capacity of the outdoor units.

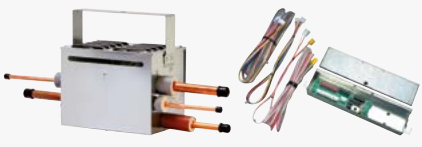
Heat recovery box

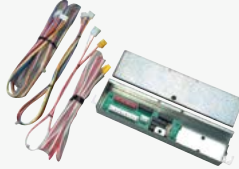

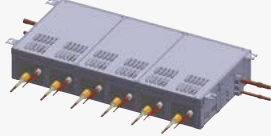
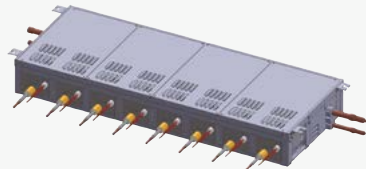
 3-Pipe control Solenoid valve kit (up to 5,6 kW). CZ-P56HR3 + CZ-CAPE2. ----- KIT-P56HR3	 Solenoid valve kit (up to 5,6 kW). ----- CZ-P56HR3	 3-Pipe control PCB. ----- CZ-CAPE2
3-Pipe control Solenoid valve kit (from 5,6 to 16,0 kW). CZ-P160HR3 + CZ-CAPE2. ----- KIT-P160HR3	Solenoid valve kit (from 5,6 kW to 16,0 kW). ----- CZ-P160HR3	3-Pipe control PCB for wall-mounted. ----- CZ-CAPEK2
 4 ports 3 pipe box (up to 5,6 kW per port). ----- CZ-P456HR3	 6 ports 3 pipe box (up to 5,6 kW per port). ----- CZ-P656HR3	 8 ports 3 pipe box (up to 5,6 kW per port). ----- CZ-P856HR3
4 ports 3 pipe box (up to 16,0 kW per port). ----- CZ-P4160HR3		

Panels

 Standard panel for 4 way 90x90 cassette. ----- CZ-KPU3W	 Econavi panel for 4 way 90x90 cassette. ----- CZ-KPU3AW	 Panel for 4 way 60x60 cassette - MY3. ----- CZ-KPY4
---	---	---



Panel for 2 way cassette (for S-22 to S-56 models).

CZ-02KPL2



Panel for 2 way cassette (for S-73 model).

CZ-03KPL2

Panel for 1 way cassette.

CZ-KPD2

Sensors



Panasonic R32 refrigerant leak detector for MU2, MY3, MM1 and MK2 models.

CZ-CGLSC1



Econavi energy saving sensor.

CZ-CENSC1



Remote temperature sensor.

CZ-CSRC3



Fresh air-intake kit.

CZ-FDU3+CZ-ATU2

NEW IAQ filter for adaptive ducted unit



BION air pollutant filter for MF3 15, 22, 28, 36, 45 and 56.

PAW-APF800F

BION Air pollutant filter for MF3 60 and 73.

PAW-APF1000F

BION Air pollutant filter for MF3 90, 106, 112, 140 and 160.

PAW-APF1400F

Plenums

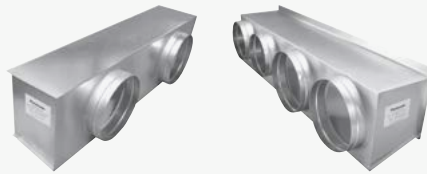

Air inlet plenum for MF3 60, 73 and 90.

CZ-DUMPA90MF2

Air inlet plenum for MM1 22, 28, 36, 45 and 56.

CZ-DUMPA22MMR2

Air outlet plenum for S-224ME1E5A.

CZ-TREMIESPW705

Air inlet plenum for MF3 106, 112, 140 and 160.

CZ-DUMPA160MF2

Air outlet plenum for MM1 22, 28 and 36.

CZ-DUMPA22MMS2

Air outlet plenum for S-280ME1E5.

CZ-TREMIESPW706

Air outlet plenum for MM1 45 and 56.

CZ-DUMPA45MMS3

Valves



Wall-mounted external valve for model sizes 15 to 56.

CZ-P56SVK2

Wall-mounted external valve for model sizes 60 to 106.

CZ-P160SVK2

E2 type high static pressure hide-away rap valve kit for 100% Fresh air function.

CZ-P160RVK2

* Plenums installed with an R32 Mini ECOi system may only be used when no Panasonic R32 refrigerant leak detector is required. Please refer to technical data manual for refrigerant installation requirements.

VRF Smart Connectivity+



Remote controller Panasonic Net Con, RH, No PIR, R1/R2.

SER8150R0B1194

Remote controller Panasonic Net Con, RH, PIR, R1/R2.

SER8150R5B1194



Wireless ZigBee® Pro module / Green Com card.

VCM8000V5094P



Hotel room expansion module 14 indoor units.

HRCEP14R



Hotel room controller 28 indoor units.

HRCPB628R

Hotel room controller w/Display 42 indoor units.

HRCPDG42R



Door/window wireless sensor.

SED-WDC-G-5045



Wall/ceiling motion/temperature/humidity sensor.

SED-MTH-G-5045



CO₂ sensor.

SED-CO2-G-5045



Sensor with room temperature and humidity.

SED-TRH-G-5045



Water leakage sensor.

SED-WLS-G-5045



Cover frame. Silver.

FAS-00



Cover frame. White.

FAS-01

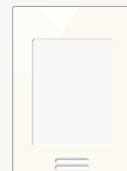

Cover frame. Glossy translucent white.

FAS-03



Cover frame. Light tan wood.

FAS-05



Cover frame. Dark brown wood.

FAS-06



Cover frame. Dark black wood.

FAS-07



Cover frame. Brushed steel finish.

FAS-10

Controller and touch controllers for hotels with dry contacts

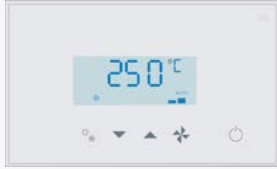

Modbus RS-485 touch room controller with I/O, white.

PAW-RE2C4-MOD-WH

Touch display control with 2 digital inputs, white.

PAW-RE2D4-WH



Modbus RS-485 touch room controller with I/O, black.

PAW-RE2C4-MOD-BK

Touch display control with 2 digital inputs, black.

PAW-RE2D4-BK

Hotel sensors for dry contacts



Wall silent motion sensor 24 V.

PAW-WMS-DC

Wall silent motion sensor 240 V AC.

PAW-WMS-AC



Ceiling silent motion sensor 24 V.

PAW-CMS-DC

Ceiling silent motion sensor 240 V AC.

PAW-CMS-AC



Power supply 24 V.

PAW-24DC



Door or window contact.

PAW-DWC

Centralised controls



System controller for 64 indoor units with weekly timer.

CZ-64ESMC3



Central ON / OFF controller, up to 16 groups, 64 indoor units.

CZ-ANC3

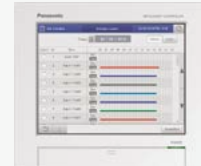

Intelligent controller (touch screen/web server) to control up to 256 indoors with included load distribution ratio (LDR).

CZ-256ESMC3

Centralised controls. BMS system. PC base



P-AIMS core software: Centralised software to control up to 1024 indoor units.

CZ-CSWKC2

P-AIMS communication adaptor.

CZ-CFUNC2

P-AIMS consumption calculation extension.

CZ-CSWAC2

P-AIMS layout display extension.

CZ-CSWGC2

P-AIMS BACnet extension.

CZ-CSWBC2

P-AIMS web application extension.

CZ-CSWWC2

Panasonic AC Smart Cloud



+ ALL REFERENCES RELATED TO AC SMART CLOUD IS IN THE DEDICATED PAGE

Panasonic AC Smart Cloud. Cloud internet control. Up to 128 groups. Controls 128 units.

CZ-CFUSCC1

NEW BMS interface with S-Link



A unified interface supporting Modbus, BACnet, and KNX protocols for up to 16 indoor units.

PAW-AC2-BMS-16

A unified interface supporting Modbus, BACnet, and KNX protocols for up to 64 indoor units.

PAW-AC2-BMS-64

A unified interface supporting Modbus, BACnet, and KNX protocols for up to 128 indoor units.

PAW-AC2-BMS-128

Accessories interfaces



Commercial Wi-Fi Adaptor.

CZ-CAPWFC1



KNX interface (Intesis).

PAW-RC2-KNX-1i



Modbus RTU interface (Intesis).

PAW-RC2-MBS-1



Modbus RTU interface to control 4 indoor/groups (Intesis).

PAW-RC2-MBS-4



BACnet IP and MSTP (Intesis).

PAW-RC2-BAC-1



KNX interface (Airzone).

PAW-AZRC-KNX-1



Modbus RTU interface (Airzone).

PAW-AZRC-MBS-1



BACnet IP and MSTP interface (Airzone).

PAW-AZRC-BAC-1



RAC interface adapter for integration into S-Link, plus external input and alarm/status output.





CZ-CAPRA1













LonWorks® Interface controls up to 16 groups and 64 indoor units.

CZ-CLNC2

Centralised controls. Connection with general equipment

 <p>Adaptor for ON / OFF control of external devices.</p> <p>-----</p> <p>CZ-CAPC3</p>	 <p>Demand control for PACi and Mini ECOi outdoor units.</p> <p>-----</p> <p>CZ-CAPDC3</p>	 <p>Mini series parallel device controlling indoor units, maximum 1 group and 8 indoor unit.</p> <p>-----</p> <p>CZ-CAPBC2</p>	 <p>Communication Adaptor. Up to 128 groups. Controls 128 units.</p> <p>-----</p> <p>CZ-CFUNC2</p>
--	--	---	--

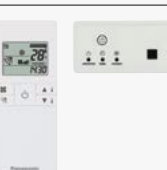
Individual controls

 <p>CONEX wired remote controller (non-wireless), white.</p> <p>-----</p> <p>CZ-RTC6W</p>	 <p>CONEX wired remote controller with Bluetooth®, white.</p> <p>-----</p> <p>CZ-RTC6WBL</p>	 <p>CONEX wired remote controller (non-wireless), black.</p> <p>-----</p> <p>CZ-RTC6</p>
 <p>CONEX wired remote controller with Bluetooth®, black.</p> <p>-----</p> <p>CZ-RTC6BL</p>	 <p>Design wired remote controller with Econavi function.</p> <p>-----</p> <p>CZ-RTC5B</p>	 <p>Infrared remote controller and receiver for 4 way 60x60 cassette - PY3 with panel.</p> <p>-----</p> <p>CZ-RWS3 + CZ-RWRY3</p>
 <p>Infrared remote controller and receiver for 4 way 90x90 cassette.</p> <p>-----</p> <p>CZ-RWS3 + CZ-RWRU3W</p>	 <p>Infrared remote controller and receiver for 2 way cassette.</p> <p>-----</p> <p>CZ-RWS3 + CZ-RWRL3</p>	 <p>Infrared remote controller and receiver for 1 way cassette.</p> <p>-----</p> <p>CZ-RWS3 + CZ-RWRD3</p>
 <p>Infrared remote controller and receiver for ceiling.</p> <p>-----</p> <p>CZ-RWS3 + CZ-RWRT3</p>	 <p>Infrared remote controller for wall-mounted and floor console.</p> <p>-----</p> <p>CZ-RWS3</p>	 <p>Infrared remote controller and receiver for all indoor units.</p> <p>-----</p> <p>CZ-RWS3 + CZ-RWRC3</p>

Accessories PCB

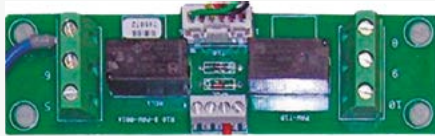

T10 interface PCB with digital and relay connections.

PAW-T10

PCB for fan speed control of external EC Fan.

PAW-ECF

R-22 Replacement Kit

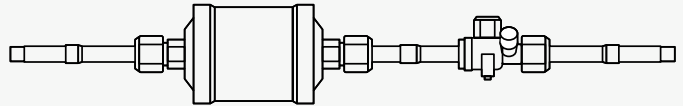

Replacement kit for R-22.

CZ-SLK2

Accessories cables

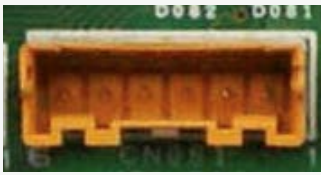

Cable for all the T10 functions.

CZ-T10



Cable to operate external EC fan.

PAW-FDC



Cable for all option monitoring signals.

PAW-OCT



Cable with force thermo OFF/leakage detection.

PAW-EXCT

Water heat exchanger accessories

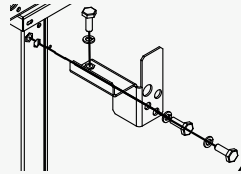

Stacking kit for vertically stacking up to 3 WHE (4 pieces per Kit).

PAW-3WSK

Smart fan coil accessories

Set of 2 legs to protect water pipes.

PAW-AAIR-LEGS-1

Motor connection cable for units with right hand hydraulic connections.

PAW-AAIR-RHCABLE

Fan coil units controllers



Electro-mechanical controller (supplied loose).

TRM-FA



Electronic controller.

Plogic



Electronic controller.

TControl EASY 3S



Electronic controller.

TControl POD glass



Wired remote controller with touch control for 2-pipe and 4-pipe, EC fan coil (control + Modbus).

PAW-FC-907EC



Wired remote controller for 2-pipe and 4-pipe, EC fan coil (control + Modbus).

PAW-FC-903EC



Advanced wired remote controller for fan coil.

PAW-FC-RC1



Smart controller. Mini building management system.

SRC

Wired remote controller with touch control for 2-pipe, AC fan coil (control only).

PAW-FC-907AC

Wired remote controller for 2-pipe, AC fan coil (control only).

PAW-FC-903AC



Plogic remote control.

WRC / MRC



Plogic remote control.

BRC



Plogic remote control.

IRC

Dimensions and tube sizes of branches and headers for 2-Pipe ECOi EX ME2 and Mini ECOi Series

Optional distribution joint kits

See the installation instructions packaged with the distribution joint kit for the installation procedure.

* In case the total capacity of indoor units connected after distribution exceeds the total capacity of the outdoor units, select the distribution piping size for the total capacity of the outdoor units.

Model name	Cooling capacity after distribution	Remarks
1. CZ-P680PH2BM	Up to 68,0 kW	For outdoor unit
2. CZ-P1350PH2BM	From 68,0 kW to 168,0 kW	For outdoor unit
3. CZ-P224BK2BM*	Up to 22,4 kW	For indoor unit
4. CZ-P680BK2BM*	From 22,4 kW to 68,0 kW	For indoor unit
5. CZ-P1350BK2BM*	From 68,0 kW to 168,0 kW	For indoor unit

Tubing size (with thermal insulation)

1. CZ-P680PH2BM: For outdoor unit side (capacity after distribution joint up to 68,0 kW).

Gas piping

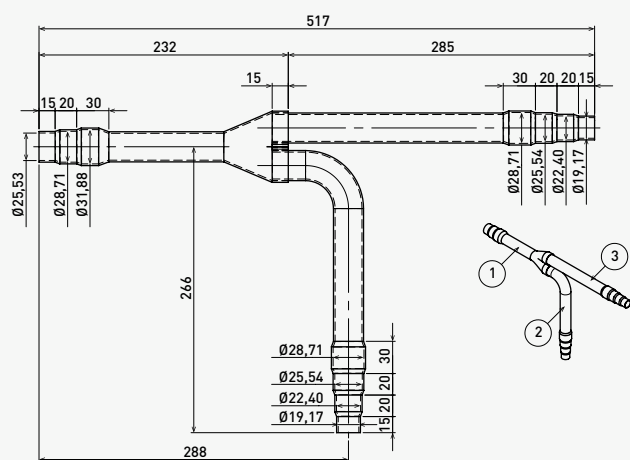

Liquid piping

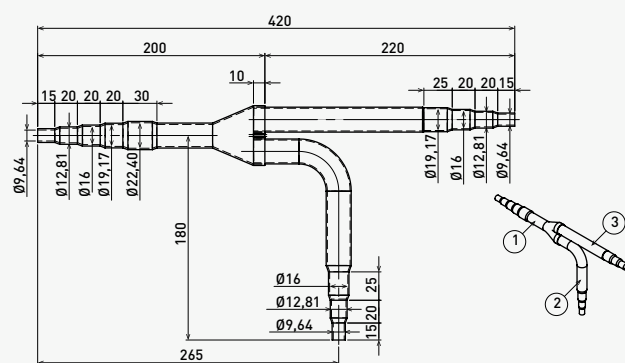

Unit: mm

2. CZ-P1350PH2BM: For outdoor unit side (capacity after distribution joint is from 68,0 kW to 168,0 kW).

Gas piping

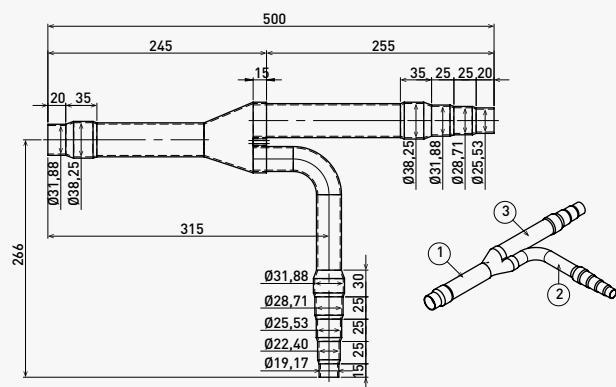

Liquid piping

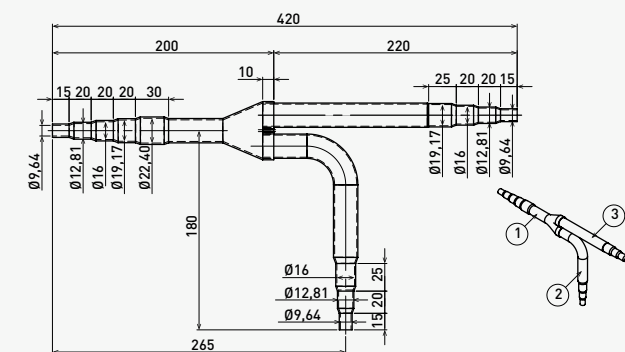

Unit: mm

3. CZ-P224BK2BM: For indoor unit side (capacity after distribution joint up to 22,4 kW).

Gas piping

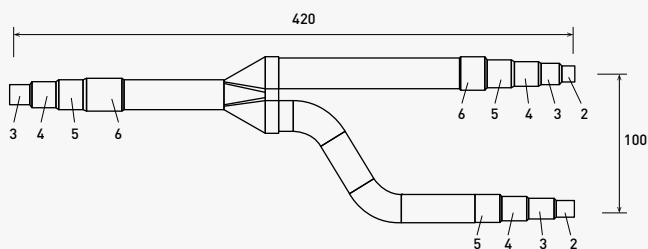

Liquid piping

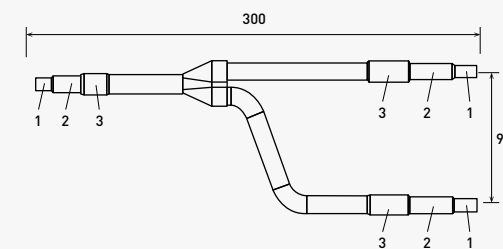

Unit: mm

4. CZ-P680BK2BM: For indoor unit side (capacity after distribution joint is from 22,4 kW to 68,0 kW).

Gas piping

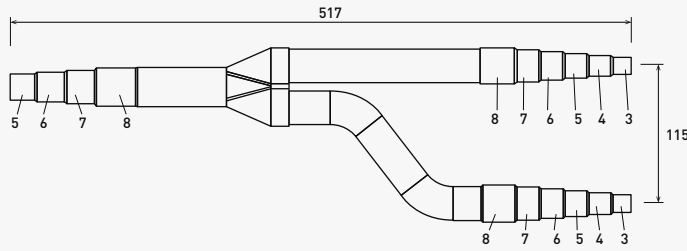

Liquid piping

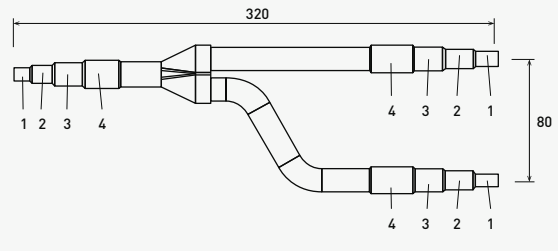

Unit: mm

5. CZ-P1350BK2BM: For indoor unit side (capacity after distribution joint is from 68,0 kW to 168,0 kW).

Gas piping

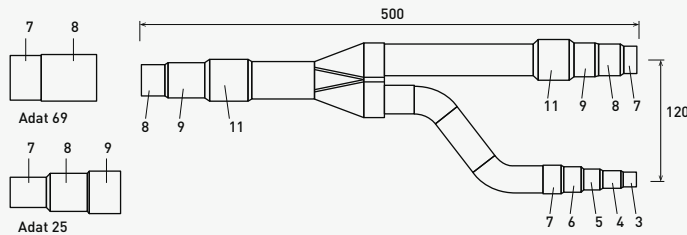

Liquid piping

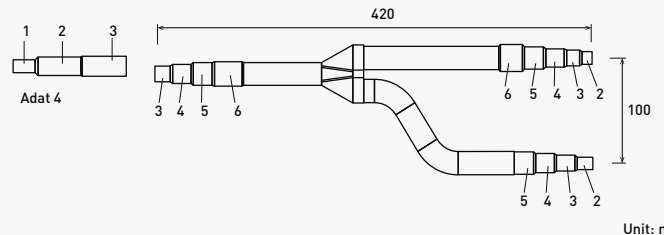

Unit: mm

Size of connection point on each part (shown are inside diameters of piping)

Diameters		1	2	3	4	5	6	7	8	9	10	11	12	13	14
Dimension	Inch	1/4	3/8	1/2	5/8	3/4	7/8	1	1 1/8	1 1/4	1 3/8	1 1/2	1 5/8	1 3/4	2
	mm	6,35	9,52	12,70	15,88	19,05	22,40	25,40	28,57	31,75	34,92	38,10	41,28	44,45	50,80

Header pipe set

CZ-P4HP4C2BM

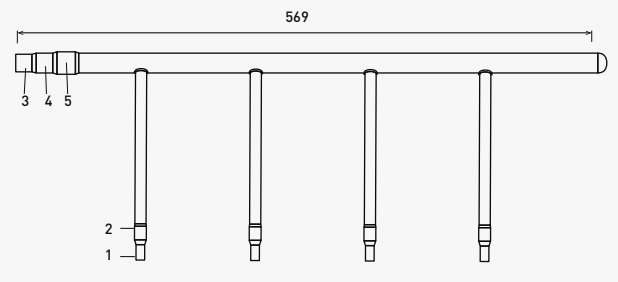
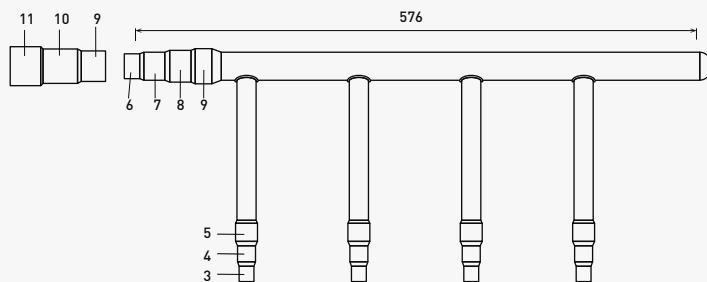

Size of connection point on each part (shown are inside diameters of piping)

Diameters		1	2	3	4	5	6	7	8	9	10	11
Dimension	Inch	1/4	3/8	1/2	5/8	3/4	7/8	1	1 1/8	1 1/4	1 3/8	1 1/2
	mm	6,35	9,52	12,70	15,88	19,05	22,40	25,40	28,57	31,75	34,92	38,10

Distribution joint Kits for Mini ECOi LE/LZ Series

CZ-P224BK2BM: For indoor unit side (capacity after distribution joint up to 22,4 kW).

Gas piping

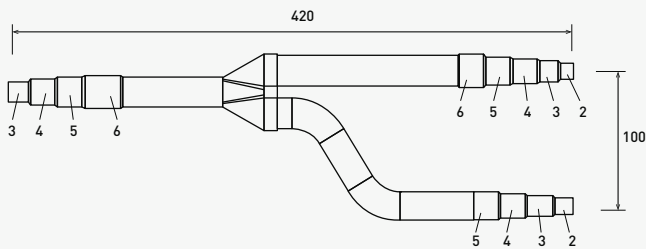

Liquid piping

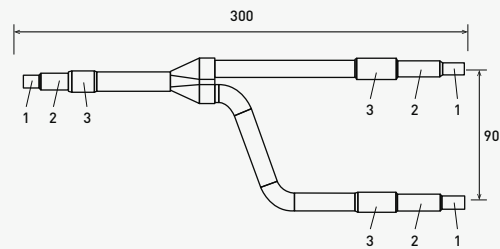

Unit: mm

Size of connection point on each part (shown are inside diameters of piping)

Diameters		1	2	3	4	5	6
Dimension	Inch	1/4	3/8	1/2	5/8	3/4	7/8
	mm	6,35	9,52	12,70	15,88	19,05	22,40

Dimensions and tube sizes of branches and headers for 3-Pipe ECOi EX MF3 Series

Optional distribution joint kits

See the installation instructions packaged with the distribution joint kit for the installation procedure.

Model name	Cooling capacity after distribution	Remarks
1. CZ-P680PJ2BM	Up to 68,0 kW	For outdoor unit
2. CZ-P1350PJ2BM	From 68,0 kW to 135,0 kW	For outdoor unit
3. CZ-P224BH2BM	Up to 22,4 kW	For indoor unit
4. CZ-P680BH2BM	From 22,4 kW to 68,0 kW	For indoor unit
5. CZ-P1350BH2BM	From 68,0 kW to 135,0 kW	For indoor unit

Piping size

1. CZ-P680PJ2BM: For outdoor unit side (capacity after distribution joint up to 68,0 kW).

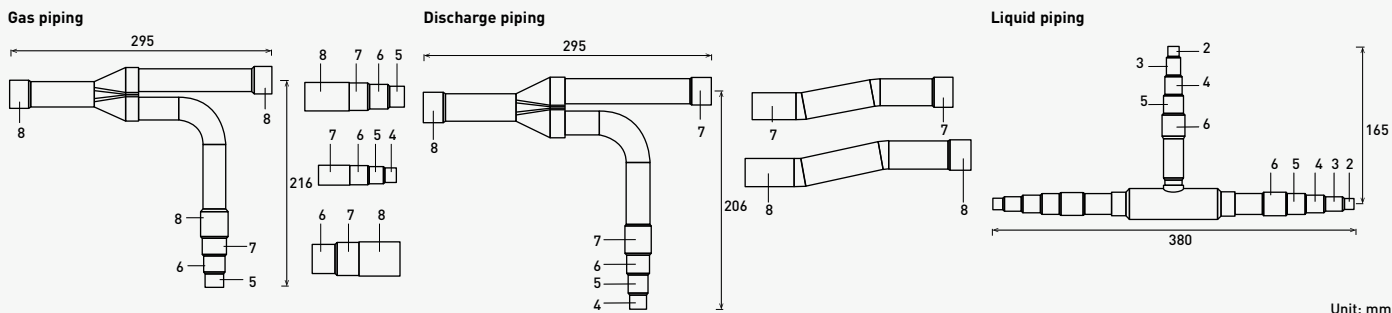

2. CZ-P1350PJ2BM: For outdoor unit side (capacity after distribution joint is from 68,0 kW to 135,0 kW).

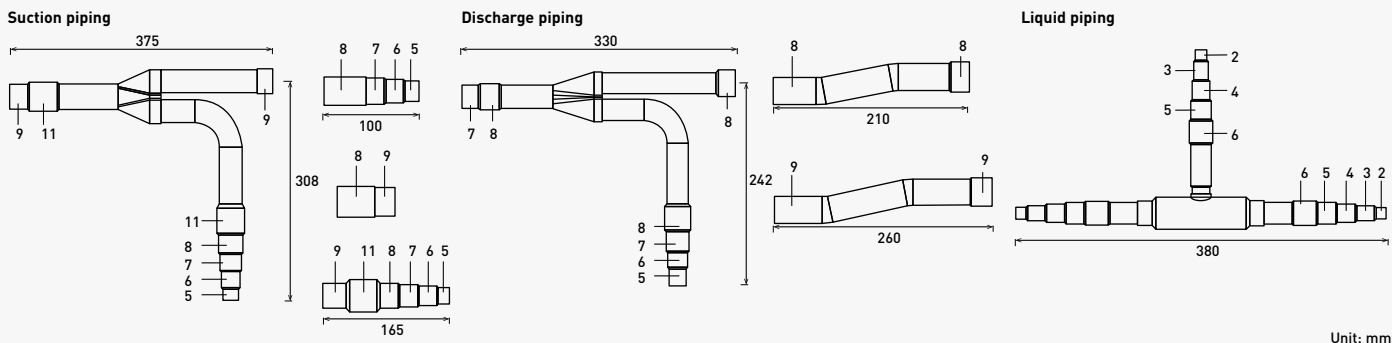

3. CZ-P224BH2BM: For indoor unit side (capacity after distribution joint up to 22,4 kW).

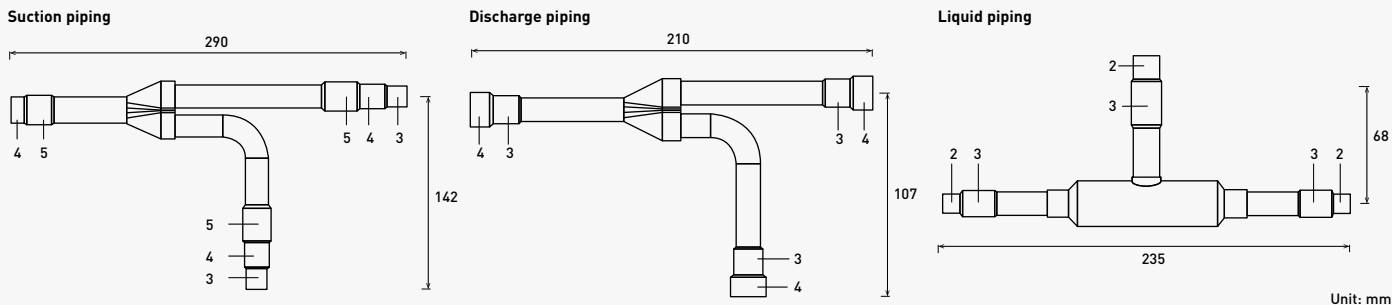

4. CZ-P680BH2BM: For indoor unit side (capacity after distribution joint is from 22,4 kW to 68,0 kW).

Suction piping

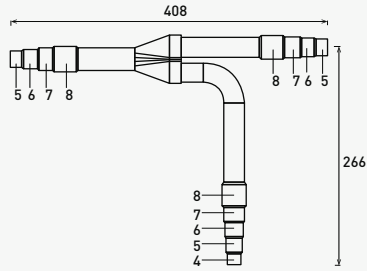

Discharge piping

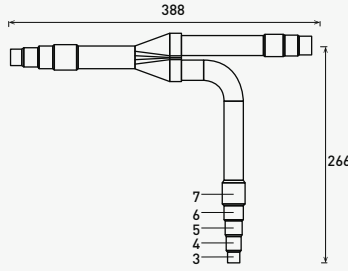

Liquid piping

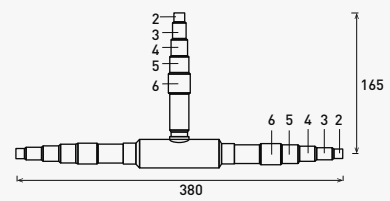

Unit: mm

5. CZ-P1350BH2BM: For indoor unit side (capacity after distribution joint is from 68,0 kW to 135,0 kW).

Suction piping

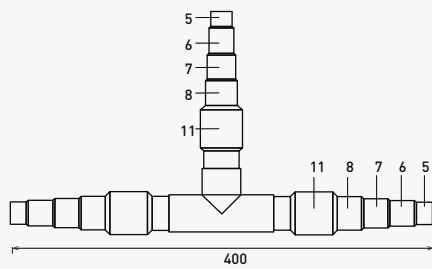

Discharge piping

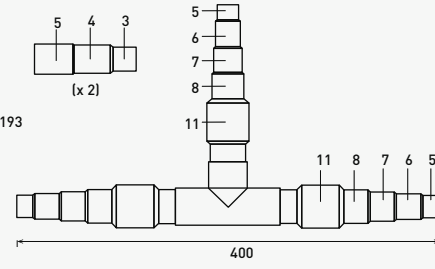

Liquid piping

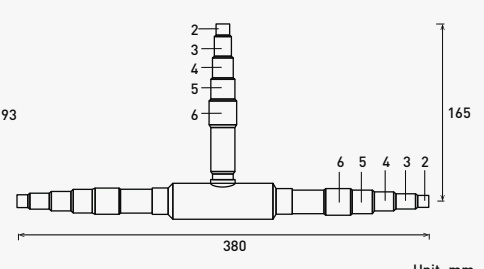

Unit: mm

Size of connection point on each part (shown are inside diameters of piping)

Diameters	1	2	3	4	5	6	7	8	9	10	11	12	13	14	
Inch	1/4	3/8	1/2	5/8	3/4	7/8	1	1 1/8	1 1/4	1 3/8	1 1/2	1 5/8	1 3/4	2	
Dimension	mm	6,35	9,52	12,70	15,88	19,05	22,40	25,40	28,57	31,75	34,92	38,10	41,28	44,45	50,80

Header pipe set

CZ-P4HP3C2BM

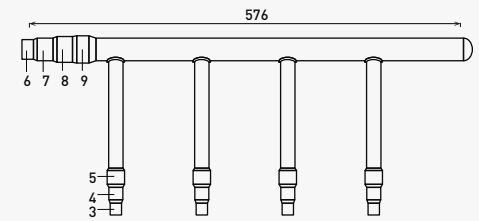
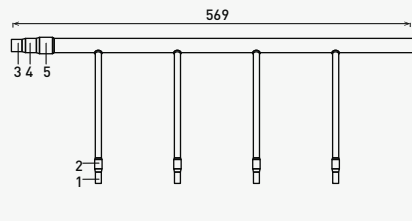
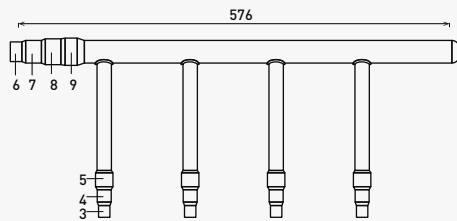

Size of connection point on each part (shown are inside diameters of piping)

Diameters	1	2	3	4	5	6	7	8	9	10	11	
Inch	1/4	3/8	1/2	5/8	3/4	7/8	1	1 1/8	1 1/4	1 3/8	1 1/2	
Dimension	mm	6,35	9,52	12,70	15,88	19,05	22,40	25,40	28,57	31,75	34,92	38,10

Eurovent certified technical data

Panasonic's PACi and VRF systems are now certified by Eurovent*. The Eurovent certification verifies the performance ratings of heating and cooling systems following European standards. Data provides products efficiency with full transparency, for the benefit of customers and professionals.

Eurovent VRF certified technical data: Mini ECOi LZ2 Series 4 to 10 HP - R32

HP		4 HP		5 HP		6 HP		8 HP		10 HP							
Outdoor unit		U-4LZ2E5		U-4LZ2E8		U-5LZ2E5		U-5LZ2E8		U-6LZ2E5		U-6LZ2E8		U-8LZ2E8		U-10LZ2E8	
Indoor units combination		MU2		MU2		MU2		MU2		MU2		MU2		MU2		MU2	
Cooling	Pc out ¹⁾	kW		12,1	12,1	14,0	14,0	15,5	15,5	22,4	22,4	28,0	28,0				
	Pec out ²⁾	kW		3,0	3,0	3,7	3,7	4,4	4,4	6,8	6,8	9,7	9,7				
	EERout			4,1	4,1	3,8	3,8	3,5	3,5	3,3	3,3	2,9	2,9				
Seasonal Cooling	SEER			8,5	8,5	8,1	8,1	7,7	7,7	7,6	7,6	7,1	7,1				
	η _{sc}	%		337,0	337,0	322,0	322,0	305,0	305,0	299,0	299,0	280,0	280,0				
Cooling PL	PcB	kW		8,9	8,9	10,3	10,3	11,4	11,4	16,5	16,5	20,6	20,6				
Condition B	EERB			6,5	6,5	5,9	5,9	5,4	5,4	5,2	5,2	4,6	4,6				
Cooling PL	PcC	kW		5,7	5,7	6,6	6,6	7,3	7,3	10,6	10,6	13,2	13,2				
Condition C	EERC			11,3	11,3	10,8	10,8	10,2	10,2	9,6	9,6	8,7	8,7				
Cooling PL	PcD	kW		5,4	5,4	5,6	5,6	5,8	5,8	9,0	9,0	9,5	9,5				
Condition D	EERD			15,6	15,6	15,2	15,2	15,0	15,0	16,6	16,6	18,0	18,0				
Seasonal Heating	Pdesignh	kW		10,0	10,0	11,2	11,2	11,6	11,6	17,5	17,5	19,6	19,6				
	SCOP			5,1	5,1	4,6	4,6	4,6	4,6	4,6	4,6	4,6	4,6				
	η _{sh}	%		199,0	199,0	181,4	181,4	180,6	180,6	180,6	180,6	181,0	181,0				
Heating PL	PhA	kW		8,8	8,8	9,9	9,9	10,3	10,3	15,4	15,4	17,3	17,3				
Condition A	COPA			3,1	3,1	2,9	2,9	2,9	2,9	2,9	2,9	2,8	2,8				
Heating PL	PhB	kW		5,4	5,4	6,0	6,0	6,2	6,2	9,4	9,4	10,5	10,5				
Condition B	COPB			4,8	4,8	4,1	4,1	4,1	4,1	4,2	4,2	4,2	4,2				
Heating PL	PhC	kW		3,5	3,5	3,9	3,9	4,0	4,0	6,2	6,2	6,7	6,7				
Condition C	COPC			7,2	7,2	7,2	7,2	7,1	7,1	6,9	6,9	7,1	7,1				
Heating PL	PhD	kW		4,0	4,0	4,0	4,0	4,0	4,0	6,7	6,7	6,9	6,9				
Condition D	COPD			9,1	9,1	9,3	9,3	9,3	9,3	8,7	8,7	9,2	9,2				
T bivalent	Tbiv	°C		-10	-10	-7	-7	-7	-7	-7	-7	-7	-7				
	PhTbiv	kW		10	10	10	10	10	10	15	15	17	17				
	COPTbiv			2,5	2,5	2,9	2,9	2,9	2,9	2,9	2,9	2,8	2,8				
Psb	W			14	14	14	14	14	14	18	18	18	18				
Psbh	W			18	18	18	18	18	18	26	26	26	26				
Poffc	W			14	14	14	14	14	14	18	18	18	18				
Poffh	W			18	18	18	18	18	18	26	26	26	26				
Ptoc	W			14	14	14	14	14	14	18	18	18	18				
Pto	W			18	18	18	18	18	18	26	26	26	26				
Pckc	W			14	14	14	14	14	14	18	18	18	18				
Pckh	W			18	18	18	18	18	18	26	26	26	26				
Sound power level		dB(A)		69	69	70	70	72	72	72	72	74	74				
Sound power level in heating		dB(A)		72	72	74	74	75	75	74	74	75	75				

Eurovent VRF certified technical data: Mini ECOi LE Series 4 to 10 HP - R410A

HP		4 HP		5 HP		6 HP		8 HP		10 HP									
Outdoor unit		U-4LE2E5		U-4LE2E8		U-5LE2E5		U-5LE2E8		U-6LE2E5		U-6LE2E8		U-8LE1E8		U-10LE1E8			
Indoor units combination		MF2		MU2		MF2		MU2		MF2		MU2		MF2		MU2			
Cooling	Pc out ¹⁾	kW		12,1	12,1	12,1	12,1	14,0	14,0	14,0	14,0	15,5	15,5	15,5	15,5	22,4	22,4	28,0	28,0
	Pec out ²⁾	kW		2,9	2,9	2,9	2,9	3,7	3,7	3,7	3,7	4,6	4,6	4,6	4,6	7,2	7,2	10,8	10,8
	EERout			4,2	4,2	4,2	4,2	3,8	3,8	3,8	3,8	3,4	3,4	3,4	3,4	3,1	3,1	2,6	2,6
Seasonal Cooling	SEER			7,8	7,8	7,8	7,8	7,5	7,5	7,5	7,5	7,2	7,2	7,2	7,2	6,3	6,3	6,4	6,4
	η _{sc}	%		311,0	311,0	311,0	311,0	296,2	296,2	296,2	296,2	286,8	286,8	286,8	286,8	247,9	247,9	251,8	251,8
Cooling PL	PcB	kW		8,9	8,9	8,9	8,9	10,3	10,3	10,3	10,3	11,4	11,4	11,4	11,4	16,5	16,5	20,6	20,6
Condition B	EERB			6,7	6,7	6,7	6,7	5,9	5,9	5,9	5,9	5,4	5,4	5,4	5,4	4,8	4,8	4,4	4,4
Cooling PL	PcC	kW		5,7	5,7	5,7	5,7	6,6	6,6	6,6	6,6	7,3	7,3	7,3	7,3	10,6	10,6	13,2	13,2
Condition C	EERC			12,1	12,1	12,1	12,1	11,0	11,0	11,0	11,0	10,2	10,2	10,2	10,2	7,8	7,8	8,2	8,2
Cooling PL	PcD	kW		2,7	2,7	2,7	2,7	2,9	2,9	2,9	2,9	3,4	3,4	3,4	3,4	8,0	8,0	9,0	9,0
Condition D	EERD			9,6	9,6	9,6	9,6	10,3	10,3	10,3	10,3	11,7	11,7	11,7	11,7	12,8	12,8	15,4	15,4
Seasonal Heating	Pdesignh	kW		10,0	10,0	10,0	10,0	12,5	12,5	12,5	12,5	13,0	13,0	13,0	13,0	17,5	17,5	19,6	19,6
	SCOP			4,9	4,9	4,9	4,9	4,4	4,4	4,4	4,4	4,2	4,2	4,2	4,2	4,2	4,2	4,3	4,3
	η _{sh}	%		191,8	191,8	191,8	191,8	172,9	172,9	172,9	172,9	166,7	166,7	166,7	166,7	166,4	166,4	169,5	169,5
Heating PL	PhA	kW		8,8	8,8	8,8	8,8	11,0	11,0	11,0	11,0	11,5	11,5	11,5	11,5	15,4	15,4	17,3	17,3
Condition A	COPA			3,5	3,5	3,5	3,5	2,8	2,8	2,8	2,8	2,6	2,6	2,6	2,6	2,7	2,7	2,6	2,6
Heating PL	PhB	kW		5,3	5,3	5,3	5,3	6,7	6,7	6,7	6,7	7,0	7,0	7,0	7,0	9,4	9,4	10,5	10,5
Condition B	COPB			4,1	4,1	4,1	4,1	3,7	3,7	3,7	3,7	3,6	3,6	3,6	3,6	3,8	3,8	3,9	3,9
Heating PL	PhC	kW		3,4	3,4	3,4	3,4	4,3	4,3	4,3	4,3	4,5	4,5	4,5	4,5	6,0	6,0	6,7	6,7
Condition C	COPC			7,7	7,7	7,7	7,7	7,5	7,5	7,5	7,5	7,4	7,4	7,4	7,4	6,6	6,6	6,8	6,8
Heating PL	PhD	kW		4,4	4,4	4,4	4,4	4,4	4,4	4,4	4,4	4,4	4,4	4,4	4,4	6,4	6,4	6,6	6,6
Condition D	COPD			9,8	9,8	9,8	9,8	9,8	9,8	9,8	9,8	9,8	9,8	9,8	9,8	8,1	8,1	8,9	8,9
T bivalent	Tbiv	°C		-10	-10	-10	-10	-9	-9	-9	-9	-7	-7	-7	-7	-7	-7	-7	-7
	PhTbiv	kW		10,0	10,0	10,0	10,0	12,0	12,0	12,0	12,0	11,5	11,5	11,5	11,5	15,4	15,4	17,3	17,3
	COPTbiv			2,9	2,9	2,9	2,9	2,6	2,6	2,6	2,6	2,6	2,6	2,6	2,6	2,7	2,7	2,6	2,6
Psb	W			9	9	9	9	9	9	9	9	9	9	9	18	18	18	18	
Psbh	W			33	33	33	33	33	33	33	33	33	33	33	48	48	48	48	
Poffc	W			9	9	9	9	9	9	9	9	9	9	9	18	18	18	18	
Poffh	W			33	33	33	33	33	33	33	33	33	33	33	48	48	48	48	
Ptoc	W			33	33	33	33	33	33	33	33	33	33	33	48	48	48	48	
Pto	W			33	33	33	33	33	33	33	33	33	33	33	48	48	48	48	
Pckc	W			33	33	33	33	33	33	33	33	33	33	33	48	48	48	48	
Pckh	W			33	33	33	33	33	33	33	33	33	33	33	48	48	48	48	
PSB	W			33	33	33	33	33	33	33	33	33	33	33	48	48	48	48	
Sound power level		dB(A)		69	69	69	69	71	71	71	71	73	73	73	73	79	79	83	83
Sound power level in heating		dB(A)		72	72	72	72	75	75	75	75	75	75	75	83	83	84	84	



Eurovent VRF certified technical data: 2-Pipe ECOi EX ME2 Series 8 to 20 HP · R410A

HP	8 HP		10 HP		12 HP		14 HP		16 HP		18 HP		20 HP		
Outdoor unit	U-8ME2E8		U-10ME2E8		U-12ME2E8		U-14ME2E8		U-16ME2E8		U-18ME2E8		U-20ME2E8		
Indoor units combination	MF2	MU2	MF2	MU2	MF2	MU2	MF2	MU2	MF2	MU2	MF2	MU2	MF2	MU2	
Cooling	Pc out ¹⁾ kW	19,7	19,7	24,6	24,6	33,5	33,5	40,0	40,0	45,0	45,0	50,0	50,0	56,0	56,0
	Pec out ²⁾ kW	5,8	5,8	8,8	8,8	11,6	11,6	13,3	13,3	18,8	18,8	17,9	17,9	23,3	23,3
	EERout	3,4	3,4	2,8	2,8	2,9	2,9	3,0	3,0	2,4	2,4	2,8	2,8	2,4	2,4
Seasonal cooling	SEER	7,4	7,4	7,0	7,0	6,7	6,7	7,2	7,2	6,4	6,4	7,6	7,6	7,0	7,0
	$\eta_{s,c}$ %	294,3	294,3	275,4	275,4	266,6	266,6	286,0	286,0	254,3	254,3	299,2	299,2	278,2	277,0
Cooling PL	PcB kW	14,5	14,5	18,1	18,1	24,6	24,6	29,4	29,4	33,1	33,1	36,8	36,8	41,2	41,2
Condition B	EERB	5,7	5,7	4,8	4,8	4,6	4,6	4,9	4,9	4,2	4,2	5,0	5,0	4,6	4,6
Cooling PL	PcC kW	9,3	9,3	11,6	11,6	15,8	15,8	18,9	18,9	21,3	21,3	23,6	23,6	26,5	26,5
Condition C	EERC	11,8	11,8	9,6	9,6	8,1	8,1	9,4	9,4	8,2	8,2	9,8	9,8	9,0	9,0
Cooling PL	PcD kW	8,2	8,2	9,3	9,3	8,2	8,2	8,4	8,4	9,4	9,4	10,5	10,5	11,7	11,7
Condition D	EERD	13,7	13,7	18,9	18,9	18,4	18,4	22,6	22,6	22,1	22,1	25,2	25,2	24,6	24,6
Seasonal heating	Pdesignh kW	17,5	17,5	22,0	22,0	26,2	26,2	31,5	31,5	35,0	35,0	39,2	39,2	44,1	44,1
	SCOP	4,8	4,8	4,3	4,3	4,7	4,7	4,3	4,3	4,1	4,1	4,3	4,3	4,1	4,1
	$\eta_{s,h}$ %	188,4	188,4	167,6	167,6	185,8	185,8	168,2	168,2	159,0	159,0	168,7	168,7	160,4	161,0
Heating PL	PhA kW	15,4	15,4	19,4	19,4	23,1	23,1	27,8	27,8	30,9	30,9	34,6	34,6	39,0	39,0
Condition A	COPA	2,8	2,8	2,6	2,6	2,8	2,8	2,5	2,5	2,3	2,3	2,6	2,6	2,4	2,4
Heating PL	PhB kW	9,4	9,4	11,8	11,8	14,1	14,1	16,9	16,9	18,8	18,8	21,1	21,1	23,7	23,7
Condition B	COPB	4,5	4,5	3,6	3,6	4,2	4,2	3,7	3,7	3,6	3,6	3,7	3,7	3,5	3,5
Heating PL	PhC kW	6,0	6,0	7,6	7,6	9,0	9,0	10,9	10,9	12,1	12,1	13,5	13,5	15,2	15,2
Condition C	COPC	7,2	7,2	7,7	7,7	7,7	7,7	7,4	7,4	6,6	6,6	7,1	7,1	6,9	6,9
Heating PL	PhD kW	7,1	7,1	7,0	7,0	7,2	7,2	6,7	6,7	6,6	6,6	7,4	7,4	7,4	7,4
Condition D	COPD	8,9	8,9	9,6	9,6	9,3	9,3	10,2	10,2	10,0	10,0	10,3	10,3	10,3	10,3
T bivalent	Tbiv °C	-9	-9	-7	-7	-9	-9	-7	-7	-7	-7	-7	-7	-7	-7
	PhTbiv kW	16,8	16,8	19,4	19,4	25,1	25,1	27,8	27,8	30,9	30,9	34,6	34,6	39,0	39,0
	COPTbiv	2,6	2,6	2,6	2,6	2,6	2,6	2,5	2,5	2,3	2,3	2,6	2,6	2,4	2,4
Psbc	W	48	48	48	48	48	48	88	88	88	88	88	88	88	88
Psbh	W	48	48	48	48	48	48	88	88	88	88	88	88	88	88
Poffc	W	48	48	48	48	48	48	88	88	88	88	88	88	88	88
Poffh	W	48	48	48	48	48	48	88	88	88	88	88	88	88	88
Ptoc	W	48	48	48	48	48	48	88	88	88	88	88	88	88	88
Ptoh	W	48	48	48	48	48	48	88	88	88	88	88	88	88	88
Pckc	W	48	48	48	48	48	48	88	88	88	88	88	88	88	88
Pckh	W	48	48	48	48	48	48	88	88	88	88	88	88	88	88
PSB	W	48	48	48	48	48	48	88	88	88	88	88	88	88	88
Sound power level	dB(A)	80	80	81	81	85	85	86	86	87	87	86	86	86	86
Sound power level in heating	dB(A)	81	81	84	84	85	85	85	85	89	89	89	89	89	89

Eurovent VRF certified technical data: 3-Pipe ECOi EX MF3 Series 8 to 16 HP · R410A

HP	8 HP		10 HP		12 HP		14 HP		16 HP		
Outdoor unit	U-8MF3E8		U-10MF3E8		U-12MF3E8		U-14MF3E8		U-16MF3E8		
Indoor units combination	MF2	MU2	MF2	MU2	MF2	MU2	MF2	MU2	MF2	MU2	
Cooling	Pc out ¹⁾ kW	22,4	22,4	28,0	28,0	33,5	33,5	40,0	40,0	45,0	45,0
	Pec out ²⁾ kW	7,2	7,2	10,8	10,8	12,9	12,9	15,4	15,4	19,6	19,6
	EERout	3,1	3,1	2,6	2,6	2,6	2,6	2,6	2,6	2,3	2,3
Seasonal Cooling	SEER	7,0	7,0	7,0	7,0	6,4	6,4	6,7	6,7	6,0	6,0
	$\eta_{s,c}$ %	277,0	277,7	278,9	278,9	252,7	252,7	264,4	264,4	237,7	237,7
Cooling PL	PcB kW	16,5	16,5	20,6	20,6	24,6	24,6	29,4	29,4	33,1	33,1
Condition B	EERB	4,9	4,9	4,6	4,6	4,3	4,3	4,4	4,4	3,9	3,9
Cooling PL	PcC kW	10,6	10,6	13,2	13,2	15,8	15,8	18,9	18,9	21,3	21,3
Condition C	EERC	9,1	9,1	9,3	9,3	7,7	7,7	8,3	8,3	7,4	7,4
Cooling PL	PcD kW	7,2	7,2	8,5	8,5	7,1	7,1	8,5	8,5	9,4	9,4
Condition D	EERD	16,5	16,5	19,7	19,7	15,7	15,7	19,7	19,7	17,4	17,4
Seasonal Heating	Pdesignh kW	17,5	17,5	22,0	22,0	26,2	26,2	31,5	31,5	35,0	35,0
	SCOP	4,8	4,8	4,2	4,2	4,3	4,3	4,1	4,1	3,8	3,8
	$\eta_{s,h}$ %	189,0	190,9	166,8	166,8	167,8	167,8	162,1	162,1	149,3	149,3
Heating PL	PhA kW	15,4	15,4	19,4	19,4	23,1	23,1	27,8	27,8	30,9	30,9
Condition A	COPA	2,9	2,9	2,5	2,5	2,7	2,7	2,4	2,4	2,2	2,2
Heating PL	PhB kW	9,4	9,4	11,8	11,8	14,1	14,1	16,9	16,9	18,8	18,8
Condition B	COPB	4,6	4,6	3,7	3,7	3,7	3,7	3,6	3,6	3,3	3,3
Heating PL	PhC kW	6,0	6,0	7,6	7,6	9,0	9,0	10,9	10,9	12,1	12,1
Condition C	COPC	7,1	7,1	7,4	7,4	6,9	6,9	7,1	7,1	6,5	6,5
Heating PL	PhD kW	6,7	6,7	6,9	6,9	6,5	6,5	6,6	6,6	6,6	6,6
Condition D	COPD	8,7	8,7	9,4	9,4	9,0	9,0	9,6	9,6	9,6	9,6
T bivalent	Tbiv °C	-9	-9	-7	-7	-9	-9	-7	-7	-7	-7
	PhTbiv kW	16,8	16,8	19,4	19,4	25,1	25,1	27,8	27,8	30,9	30,9
	COPTbiv	2,6	2,6	2,5	2,5	2,3	2,3	2,4	2,4	2,2	2,2
Psbc	W	17	17	17	17	17	17	25	25	25	25
Psbh	W	50	50	50	50	50	50	91	91	91	91
Poffc	W	17	17	17	17	17	17	25	25	25	25
Poffh	W	50	50	50	50	50	50	91	91	91	91
Ptoc	W	17	17	17	17	17	17	25	25	25	25
Ptoh	W	50	50	50	50	50	50	91	91	91	91
Pckc	W	50	50	50	50	50	50	91	91	91	91
Pckh	W	50	50	50	50	50	50	91	91	91	91
PSB	W	50	50	50	50	50	50	91	91	91	91
Sound power level	dB(A)	79	79	80	80	84	84	86	86	86	86
Sound power level in heating	dB(A)	77	77	82	82	86	86	86	86	88	88